

THIS DRAWING IS UNPUBLISHED. RELEASED FOR PUBLICATION  
 © COPYRIGHT BY TYCO ELECTRONICS CORPORATION. ALL RIGHTS RESERVED.

LOC	DIST	REVISIONS			
P	LTR	DESCRIPTION	DATE	DWN	APVD
G	14				
	D	REV PER 0G3A-0292-04	16APR04	JR	MS

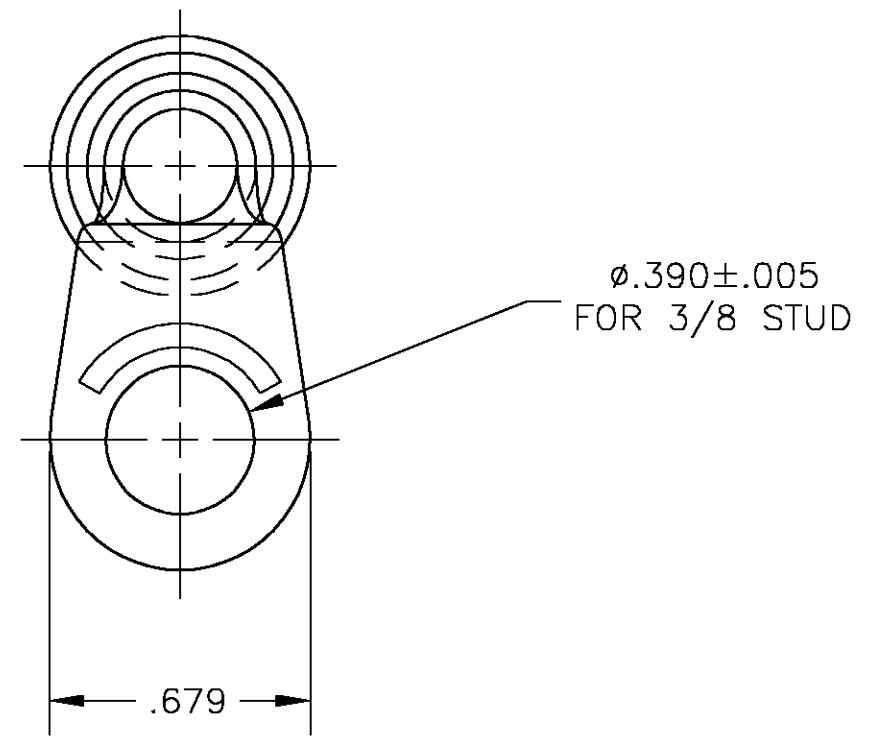
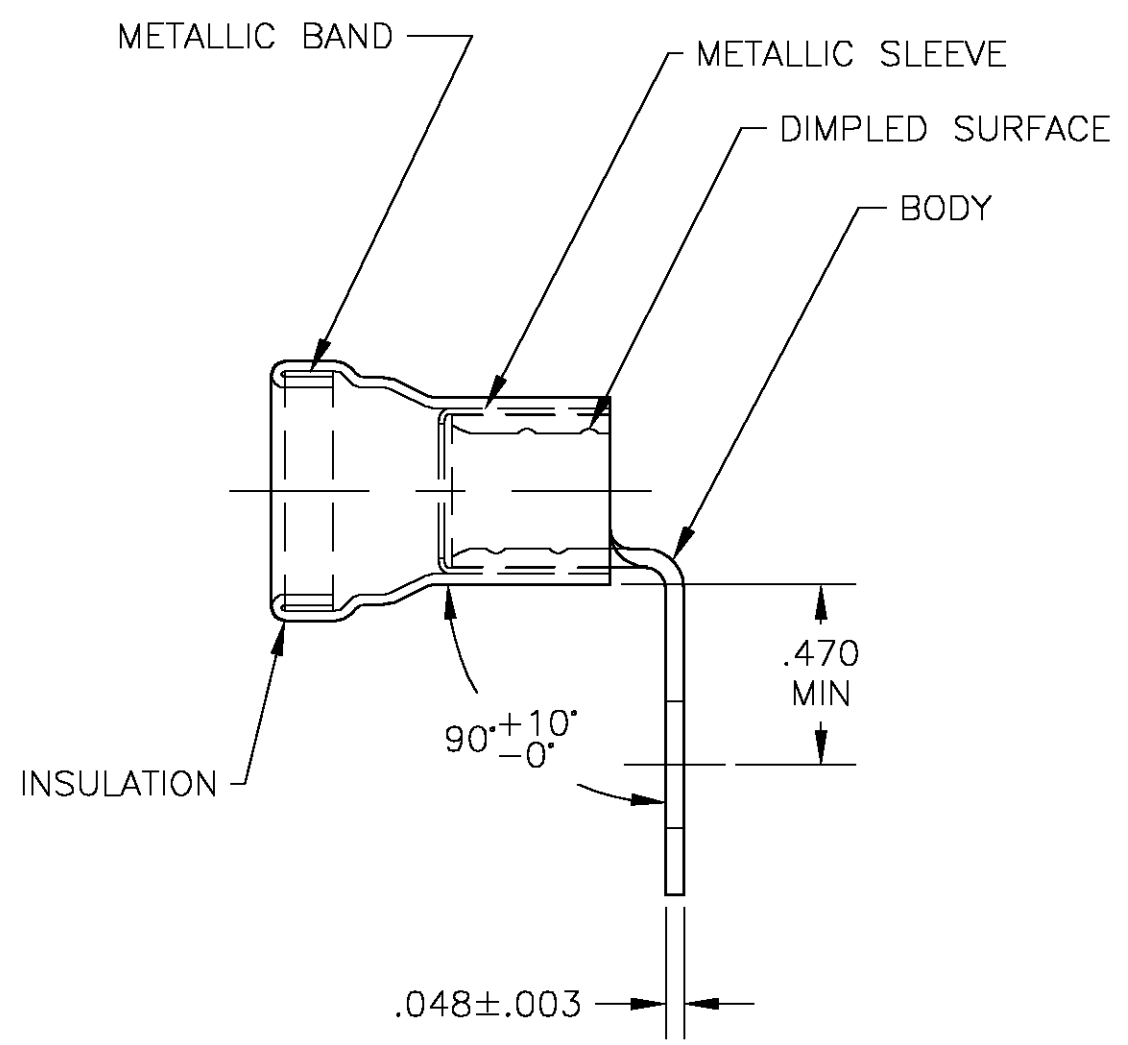

- 1 FOR .436 MAX WIRE INSULATION DIA
- 2 MATERIAL: BODY - COPPER PER ASTM B-152  
INSULATION - PVC  
METALLIC SLEEVE - COPPER PER ASTM B-152  
METALLIC BAND - STEEL PER ASTM A-109
- 3 FINISH: BODY - TIN PLATE PER ASTM B-545  
INSULATION - YELLOW

322898  
PART NO

THIS DRAWING IS A CONTROLLED DOCUMENT.		DWN jr_ruth 16APR04	Tyco Electronics Corporation Harrisburg, PA 17105		
DIMENSIONS: INCHES		CHK MJ SPICER 16APR04			
		APVD MJ SPICER 16APR04	NAME WIRE TERMINAL AMPLI-BOND, RING TONGUE, BENT 90, WIRE SIZE: #4		
TOLERANCES UNLESS OTHERWISE SPECIFIED:		PRODUCT SPEC	RESTRICTED TO		
0 PLC ± -		APPLICATION SPEC	SIZE	CAGE CODE	DRAWING NO
1 PLC ± -		WEIGHT	A3	00779	C-322898
2 PLC ± -		CUSTOMER DRAWING	SCALE	SHEET	OF
3 PLC ± .008			2:1	1	1
4 PLC ± -					REV
ANGLES ± 5°					D
MATERIAL - 2					
FINISH - 3					