

THIS DRAWING IS UNPUBLISHED. RELEASED FOR PUBLICATION
 © COPYRIGHT - By - ALL RIGHTS RESERVED.

REVISIONS				
P	LTR	DESCRIPTION	DATE	APVD
C1		REVISED PER ECO-14-017800	26NOV2014	NK DR
C2		REVISED PER ECO-17-008806	20FEB2018	RS DR

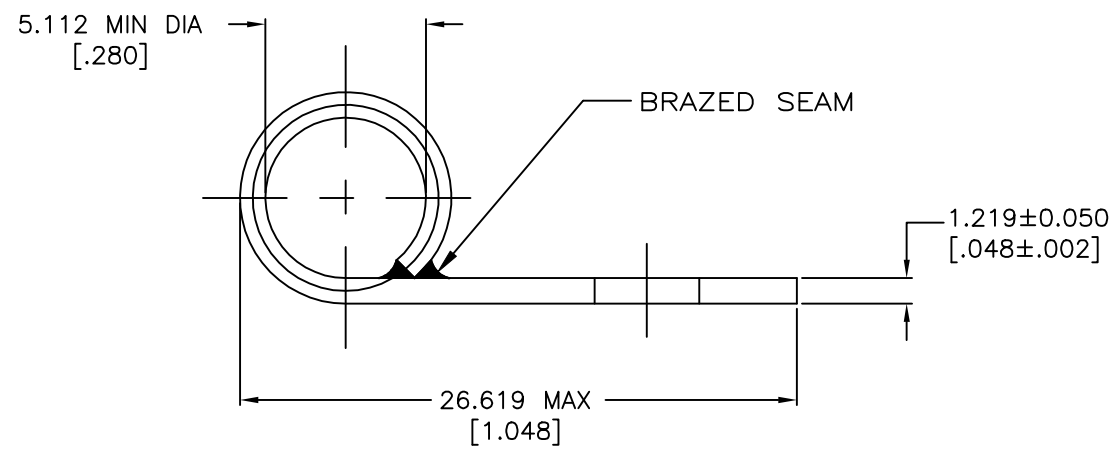
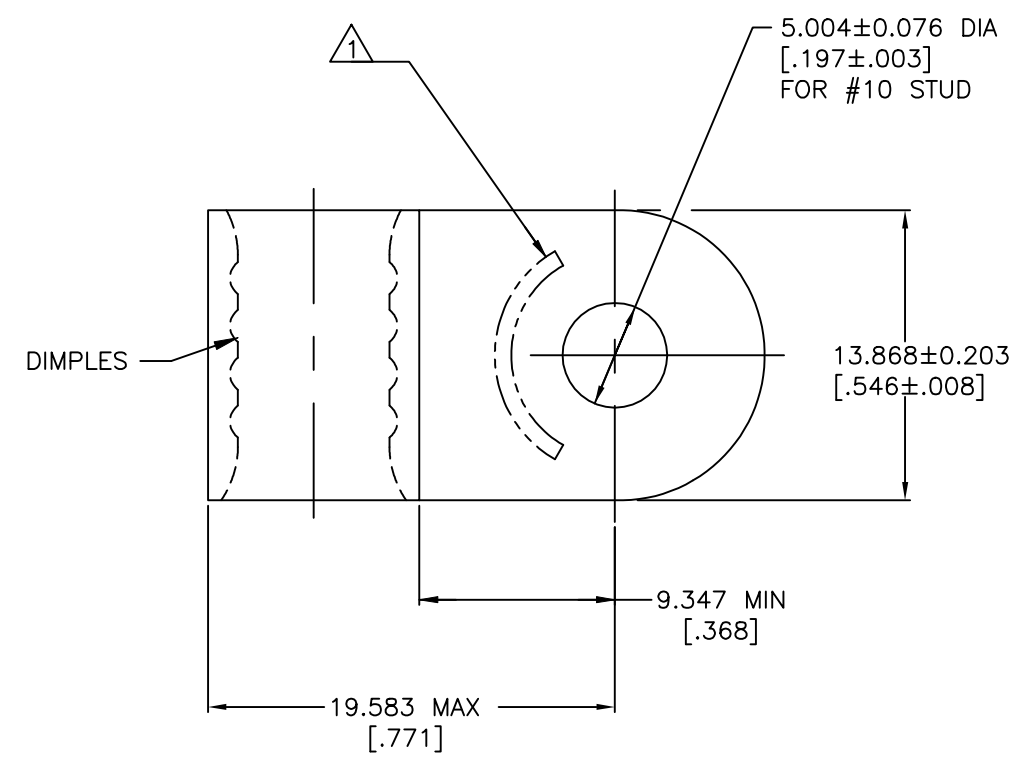

AMP WIRE RANGE	E13288 Listed
4 AWG SOLID OR STRANDED	4 AWG STRANDED
LR7189 Certified	MILITARY P/N AND CLASS
SOLID OR STRANDED	NOT APPLICABLE

- ① STAMP AMP 4W* APPROX AS SHOWN.
- ② TIN PLATE 0.00254[.000100] MIN
EXT. THK. PER ASTM B545.
- 3 NOTE DELETED
- 4 NOTE DELETED

AMP INCORPORATED CUSTOMER SERVICE SYSTEMS		MAX RECOMMENDED OPERATING TEMPERATURE: SEE TABLE
FOR ADDITIONAL PRODUCT INFORMATION OR COPIES OF DRAWINGS AND TECHNICAL DOCUMENTS	PRODUCT INFORMATION CENTER 1-800-522-6752	VOLTAGE RATING: NOT APPLICABLE
FOR APPLICATION TOOLING INFORMATION	TOOLING ASSISTANCE CENTER 1-800-722-1111	WIRE CROSS SECTIONAL AREA RANGE: 16.8-26.7mm ² [33,100-52,600] CIR MILS SOLID OR STRANDED
FOR ORDER ENTRY	1-800-526-5142	THIS DRAWING IS A CONTROLLED DOCUMENT FOR AMP INCORPORATED. IT IS SUBJECT TO CHANGE AND THE CONTROLLING ENGINEERING ORGANIZATION SHOULD BE CONTACTED FOR THE LATEST REVISION.

100	LOOSE PIECE	170°C [338°F]	②	321059
QTY	PACKAGE TYPE	MAX OPERATING TEMP	FINISH	PART NUMBER
THIS DRAWING IS A CONTROLLED DOCUMENT.		DWN TA BRINKMAN 4-8-93	TE Connectivity Ltd.	
DIMENSIONS: mm[INCHES]	TOLERANCES UNLESS OTHERWISE SPECIFIED:	CHK DA PATTERSON 4-8-93	NAME DE MILLER 4-8-93	
	0 PLC ± - 1 PLC ± - 2 PLC ± - 3 PLC ± .127[.005] 4 PLC ± - ANGLES ± -	APVD DE MILLER 4-8-93	PRODUCT SPEC UL 486 A-B	
MATERIAL COPPER PER ATSM B-152 ANNEALED	FINISH ②	APPLICATION SPEC -	SIZE A2	CAGE CODE 00779
CUSTOMER DRAWING		WEIGHT -	DRAWING NO C-321059	RESTRICTED TO -
		SCALE 4:1	SHEET 1 of 1	REV C2