

4

3

2

1

THIS DRAWING IS UNPUBLISHED.

RELEASED FOR PUBLICATION

ALL RIGHTS RESERVED.

© COPYRIGHT - By -

REVISIONS

P	LTR	DESCRIPTION	DATE	DWN	APVD
U1		REVISED PER ECO-11-004917	11MAR11	RK	HMR
U2		REVISED PER ECO-17-008114	01JUN2018	RS	DR

<b>AMP</b> WIRE RANGE	E13288 Listed	LR7189 Certified
22-16 AWG SOLID OR STRANDED	22-16 AWG SOLID OR STRANDED	22-16 AWG SOLID OR STRANDED

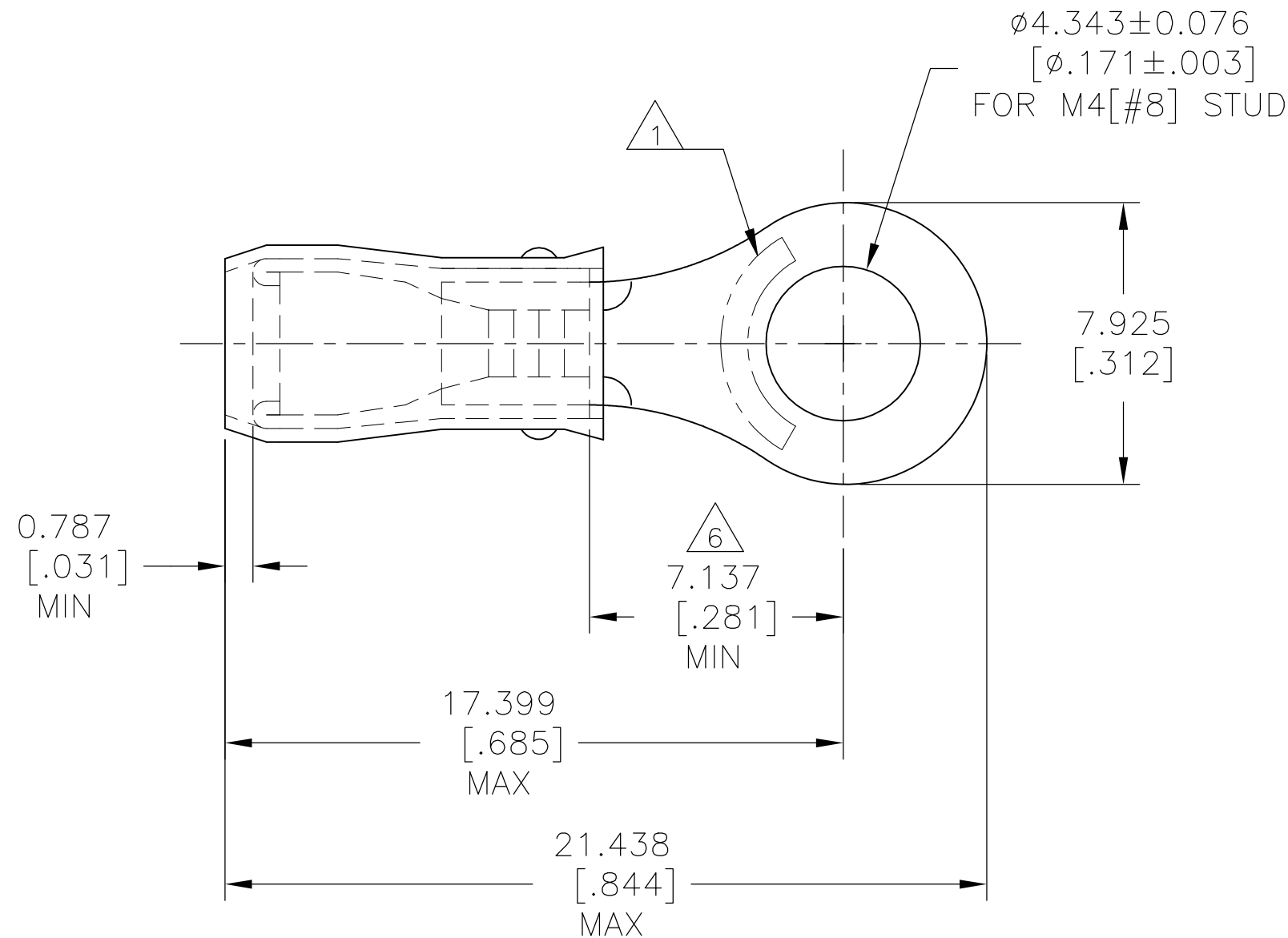

- 1 STAMP AMP 22-18\* APPROX AS SHOWN  
22-16 TERMINALS ARE STAMPED 22-18  
IN ACCORDANCE WITH MILITARY SPEC  
SAE AS7928 COMMERCIAL WIRE RANGE IS  
22-16
- 2 WIRE INSULATION DIA:  
2.032-3.175 [.080-.125]
- 3 TONGUE MATERIAL THK:  
0.787±0.051 [.031±.002]
- 4 TIN PL 0.00254 [.000100] MIN EXT THK  
PER ASTM B545
- 5 NOTE DELETED
- 6 APPLIES FROM EDGE OF METAL WIRE  
BARREL TO CENTER OF STUD

1000	LOOSE PIECE	31888
QUANTITY	PACKAGE TYPE	PART NO

AMP INCORPORATED  
CUSTOMER SERVICE SYSTEMS

THIS DRAWING IS A CONTROLLED DOCUMENT.

DWN DK SCHRUM 02/11/93

CHK RE HERSEY 4/28/93

APVD ML ELLIS 4/28/93

TE Connectivity Ltd.

FOR ADDITIONAL  
PRODUCT INFORMATION OR  
COPIES OF DRAWINGS  
AND TECHNICAL DOCUMENTS

PRODUCT INFORMATION CENTER  
1-800-522-6752

MAX RECOMMENDED OPERATING  
TEMPERATURE:  
105°C [221°F]

VOLTAGE RATING:  
300 V MAX

DIMENSIONS:  
mm [INCHES]

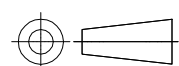

TOLERANCES UNLESS  
OTHERWISE SPECIFIED:

- 0 PLC ± -
- 1 PLC ± -
- 2 PLC ± -
- 3 PLC ± 0.127 [.005]
- 4 PLC ± - ± -
- ANGLES ± -

PRODUCT SPEC  
UL 486A-B

APPLICATION SPEC  
114-2157

NAME  
TERMINAL, RING TONGUE,  
PIDG™, WIRE SIZE, 22-16 AWG

FOR APPLICATION  
TOOLING INFORMATION

TOOLING ASSISTANCE CENTER  
1-800-722-1111

WIRE CROSS SECTIONAL AREA RANGE,  
0.26-1.65mm² [509-3,260] CIR MILS  
SOLID OR STRANDED

MATERIAL  
COPPER PER ASTM B-152  
SLEEVE, RED VINYL

FINISH



WEIGHT

CUSTOMER DRAWING

SIZE A3  
CAGE CODE 00779  
DRAWING NO C-31888

RESTRICTED TO -  
SCALE 6:1 SHEET 1 of 1 REV U2