

PRELIMINARY

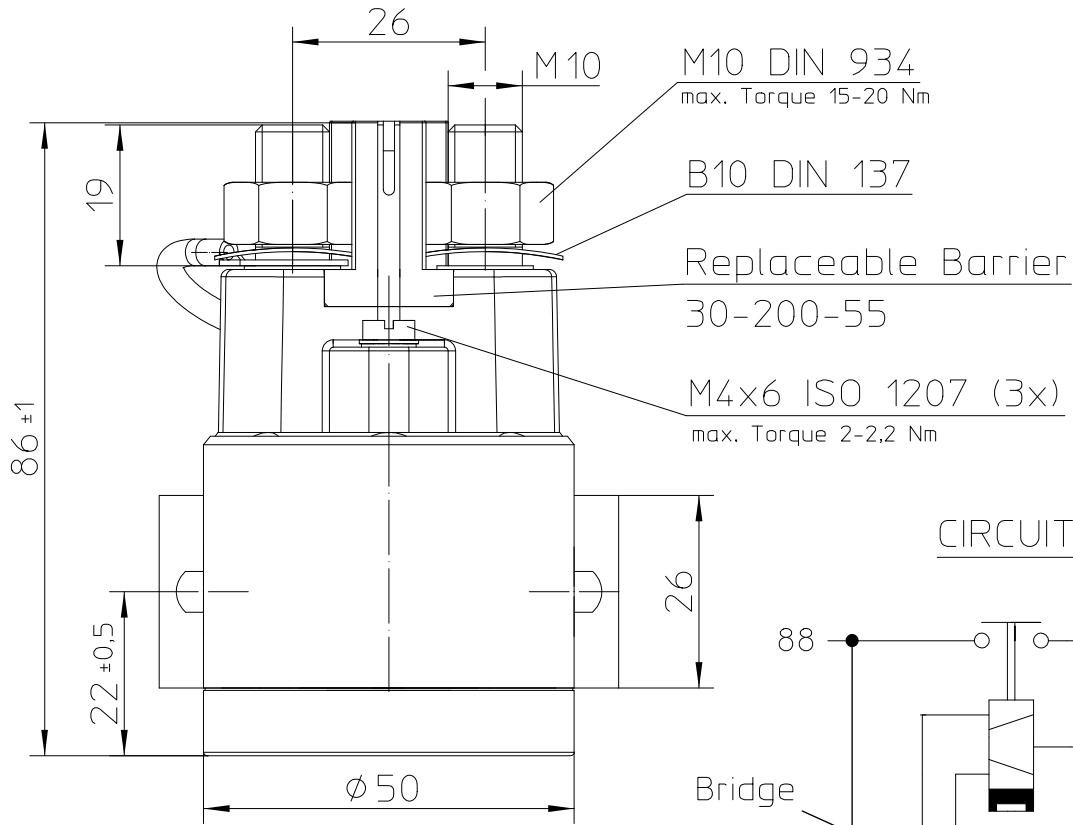

CIRCUIT:

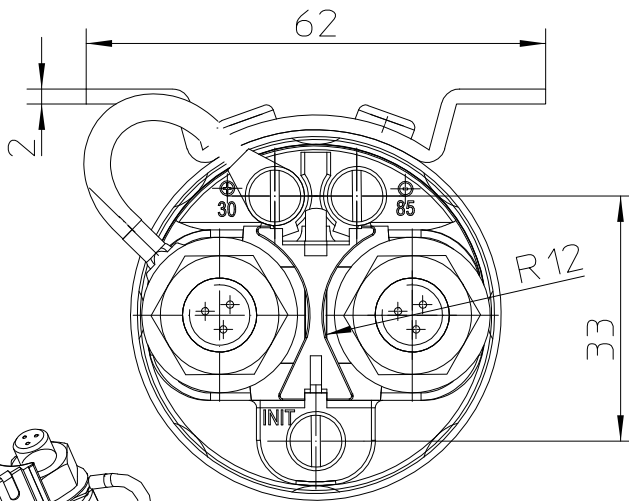
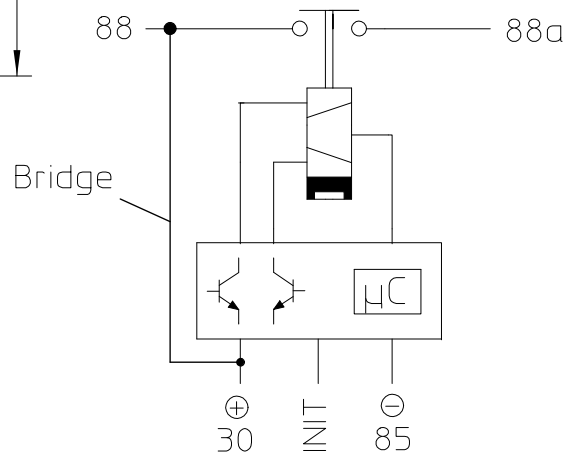

MOUNTING DIMENSION:

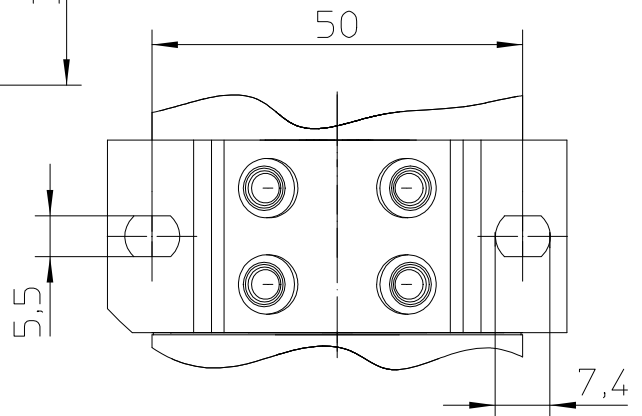

ISO:

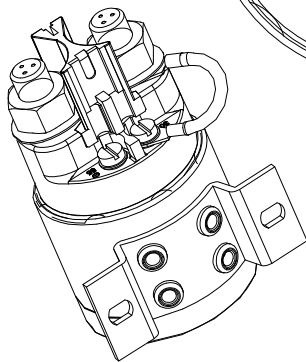

	Date	Name	mm	Scale		Drawing No:
Drawn	07.04.2011	Kaise	↔	1:1		31-311-12-i-914
Check	07.04.2017	Kaise	General Tolerances			NSN:

Technical Data

The technical principle of this relay is a proved two coil device with a Pull In and Drop Out coil with permanent powerless magnetic holding. An impulse into the controlled coil switches the relay into an On or Off position. The end-position will permanentmagnetic held, without energy requirement. An integrated electronic unit in the relay assume the protected coil activation, therefore it is impossible to actuate faulty or improperly. At the clamp 30(+) and 85(-) applied the permanent-supply. The selection ensured powerless from INIT. A HIGH-level activate the relay, a LOW-level disconnect it.

If the monostable activation keep use, the INIT-activation is an advantage. The electronic is short-circuit protected and a safety coil-selection, reverse polarity protected and coil-deletion. The integrated undervoltage protection insures the relay to undefined operating conditions. All geometric size and measurement are identical to those of a standard bi-stable 30-series relay which therefore offers the user an interchangeable solution.

ENVIRONMENTAL CHARACTERISTICS

TEMPERATURE RANGE -40°C TO +85°C (-40°F TO +185°F)
 MAX. ALTITUDE RATING 50 000 FT
 SEAL IEC 529, 2. EDITION 1989-IP67 (6 FT/ 1 MIN.) AND IP6K9K
 SHOCK G-LEVEL 6G/ 11 MSEC
 VIBRATION 4G/ 50-2000 Hz

ELECTRICAL CHARACTERISTICS

MIN. INSULATION RESISTANCE INITIAL 100 MEGOHMS
 AFTER LIVE OR ENVIRONMENTAL 50 MEGOHMS
 DIELECTRIC WITHSTANDING VOLTAGE 1 050 VAC/ 1 MIN
 MAX. CONTACT DROP, INITIAL 0,15 VDC
 AFTER LIFE TEST 0,175 VDC
 OVERLOAD 2400 AMP FOR 1 SEC., 600 AMP FOR 20 SEC.
 RUPTURE CURRENT 3000 AMP
 DUTY RATING 300 AMP CONTINUOUS
 QUIESCENT CURRENT APPROX 1 mA

RATED CONTACT LOAD

MOTOR LOAD 50 000 CYCLES
 MECHANICAL LIFE 100 000 CYCLES

ELECTRONICS AND OPERATING CHARACTERISTICS

VOLTAGE RANGE 16-32 VDC
 NOMINAL VOLTAGE 24 VDC
 PICK UP CURRENT AT 24 VDC APPROX 2,9 A FOR 50 MSEC
 DROP OUT CURRENT AT 24 VDC APPROX 3,0 A FOR 50 MSEC

OPERATING FUNCTION

DROP OUT <=23,9 VDC FOR >30 SECONDS

OPTIONAL CONTROL-CIRCUIT (INIT)

CONTROL SIGNAL ANALOGE
 THRESHOLD VOLTAGE HIGH >16 VDC
 TOLERANCE ±1,0 VDC
 DEBOUNCING 25 MSEC

CIRCUIT TIME

PICK UP TIME 200 MSEC APPROX
 BOUNCE 5 MSEC MAX.

WEIGHT 0,55 KG = 1,21 POUND MAX.
 WIRE SECTION (AT NOMINAL LOAD) MIN. 95mm²/ 0,147 sq. in./ AWG 0000

SUBJECT TO CHANGE

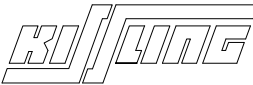
	Date	Name	mm	Scale		Drawing No:
Drawn	07.04.2011	Kaise	↔	1:1		31-311-12-i-914
Check	07.04.2017	Kaise	General Tolerances			NSN: