

Suppression Diode
30-100-50

CIRCUIT

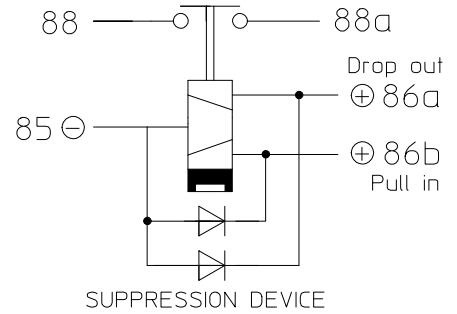

MOUNTING DIMENSION

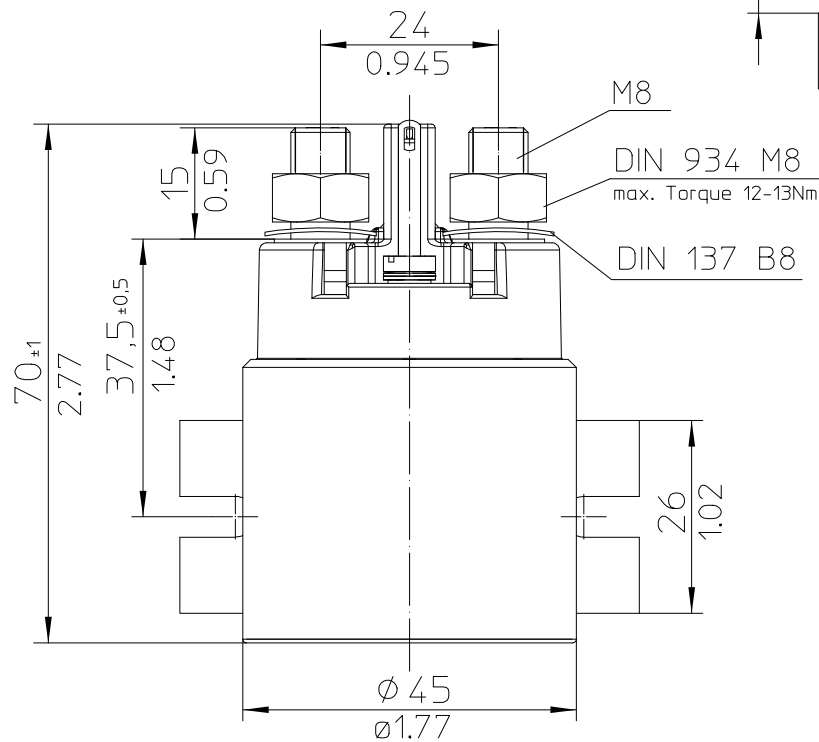
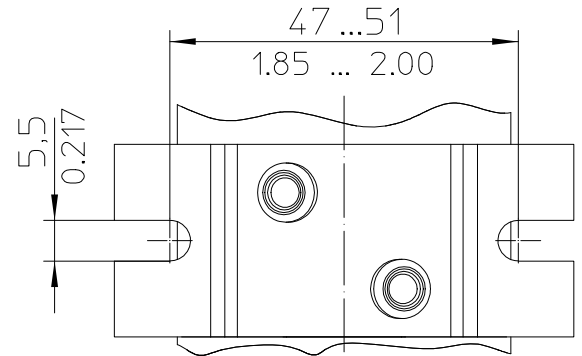

Third Angle Projection

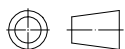

DIMENSIONAL TOLERANCES
3 PLACE DECIMAL ±0.010
2 PLACE DECIMAL ±0.03
ANGULAR ±0°30'

For this drawing we reserve the copyright in accordance with DIN ISO 16016

	Date	Name	mm inch	Scale 1:1		Drawing No:
Create	03.06.2013	Seege				30-111-11
Edited	25.10.2019	Mielk	General Tolerances DIN ISO 2768 cL			
Check	25.10.2019	Kaise				NSN:

