

REVISIONS					
ZONE	LTR	ECN	DESCRIPTION	DATE	APPROVED
L	24767		REV. REDRAWN DRG. BY GFF/MFM 5/11/80	5/11/80	[Signature]
M	40056		UPDATE REV. LETTER.	3/21/90	[Signature]

CABLE ACCEPTANCE DIMENSIONS
 JACKET DIA. .093 MAX.
 SHIELD DIA. .075 MAX.
 DIELECTRIC DIA. .059 MAX.
 INNER CONDUCTOR DIA. .015 MAX.

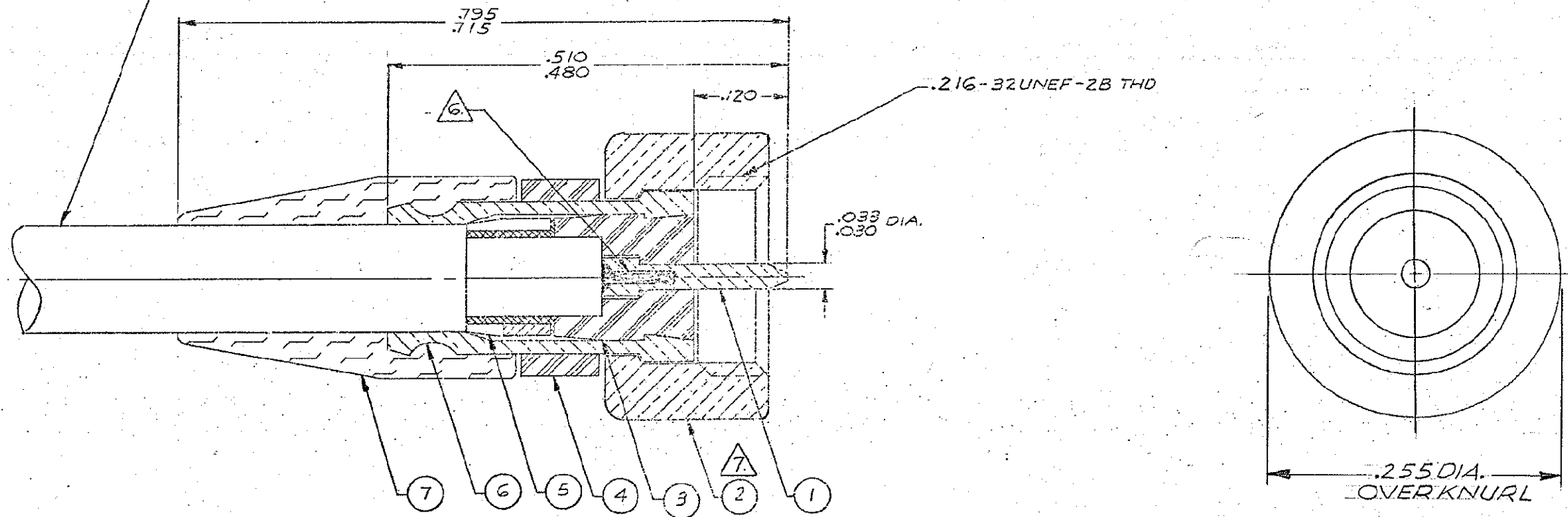

NOTES: UNLESS OTHERWISE SPECIFIED.
 1. THIS CONNECTOR MATES WITH ALL S-TO JACKS AND RECEPTACLES AS LISTED IN MALCO CATALOG.
 2. SILVER PLATE .0002 MIN. PER QQ-S-365, TYPE II, GRADE A.
 3. GOLD PLATE PER MIL-G-45204, TYPE II, GRADE C, CLASS I.
 4. FOR ASSEMBLY INSTRUCTIONS SEE RF-ASMB-95
 5. MALCO ASSEMBLY TOOL # 010-0004-0000 REQ'D.
 6. INNER CONDUCTOR SOLDERED TO PIN CONTACT.
 7. MALE DIAMOND KNURL.

QTY REQD	PART NO.	DESCRIPTION	MAT'L AND SPEC.	ITEM NO.
1	003-0041-0000	BEND RELIEF CAP	NEOPRENE, MIL-R-3065	7
1	003-0167-0001	FERRULE	BRASS, QQ-B-626	6
1	003-0161-0001	JERK RING	BRASS, QQ-B-626	5
1	003-0598-0001	SLEEVE PIN PROT'R	TEFLON, L-P-403	4
1	000-0301-0130	INSULATOR	TEFLON, L-P-403	3
1	003-0043-0001	NUT	BRASS, QQ-B-626	2
1	003-0360-0002	CONTACT, PIN	BRASS, QQ-B-626	1

UNLESS OTHERWISE SPECIFIED DIMENSIONS ARE IN INCHES TOLERANCES ARE: FRACTIONS DECIMALS ANGLES ± .XX ± .010 ±		CONTRACT NO.		MALCO A MICRODOT COMPANY, INC. 306 PASADENA AVE., 30. PASADENA, CALIF. 91030	PROD CODE
MATERIAL NOTED		APPROVALS: DRAWN HENNY G. 3/21/79, CHECKED [Signature] 9/2/80, PR. ENG. [Signature] 9/16/80, APPD. [Signature] DATE: 3/21/79			931
FINISH NOTED		SIZE: B CONE IDENT NO.: 03278 DRAWING NO.: 032-0022-0001		CCM	
NEXT ASSY		DO NOT SCALE DRAWING		SHEET / OF	

DISHOP GRAPHIC/ACULPRESS REORDER NO. 2197