

REVISIONS					
P	LTR	DESCRIPTION	DATE	DWN	APVD
A		ECN-24-263831	29APR2024	IS	RJ

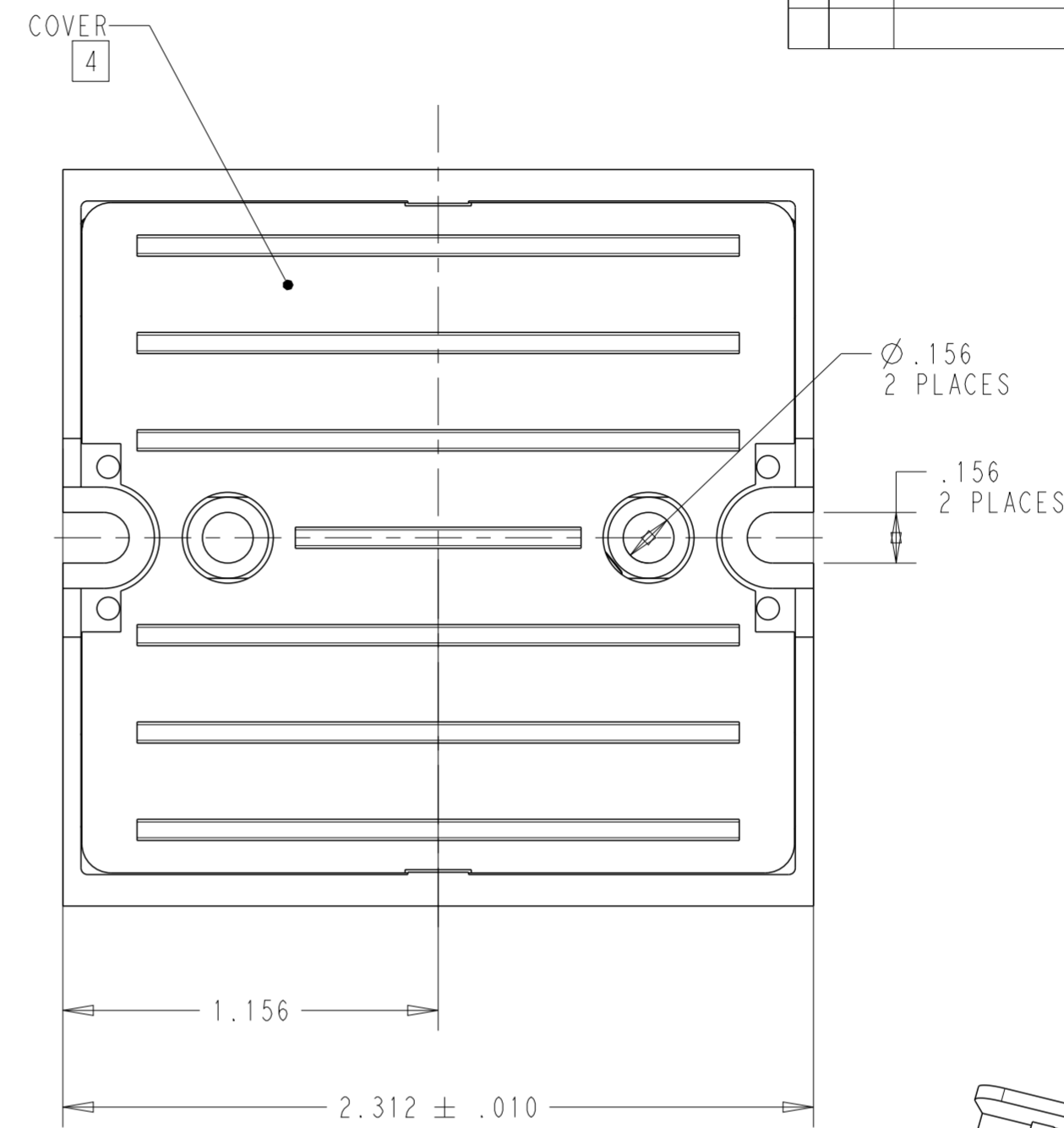

BOTTOM VIEW

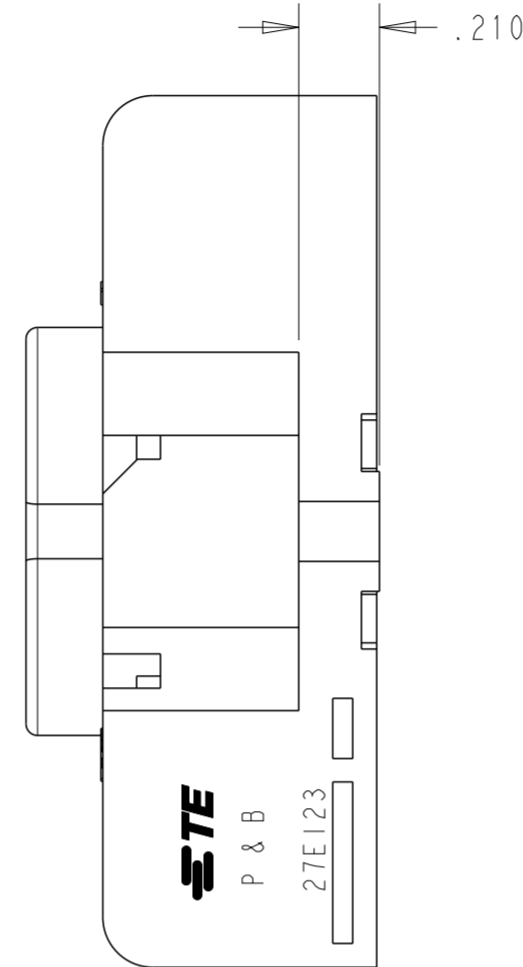
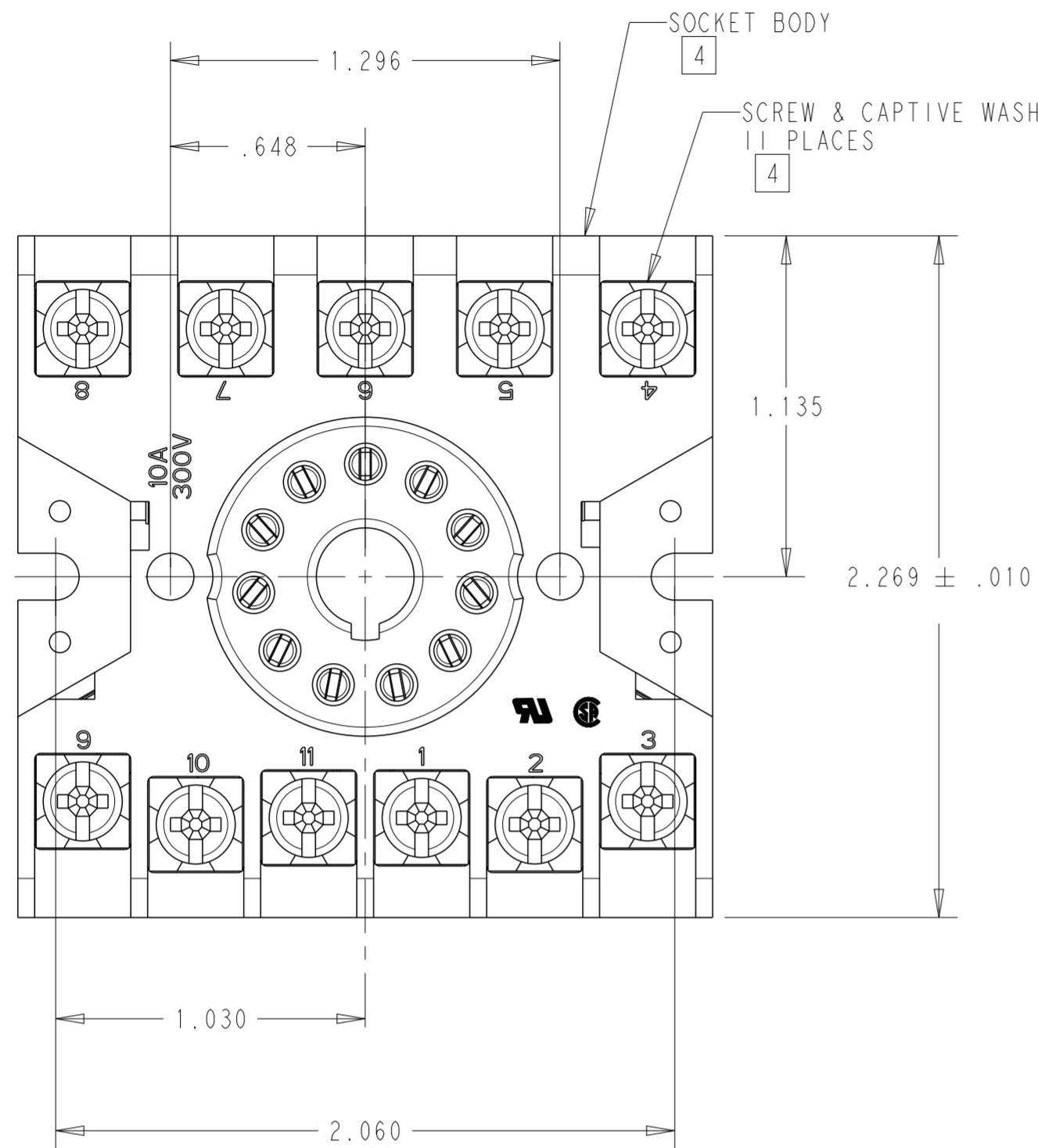
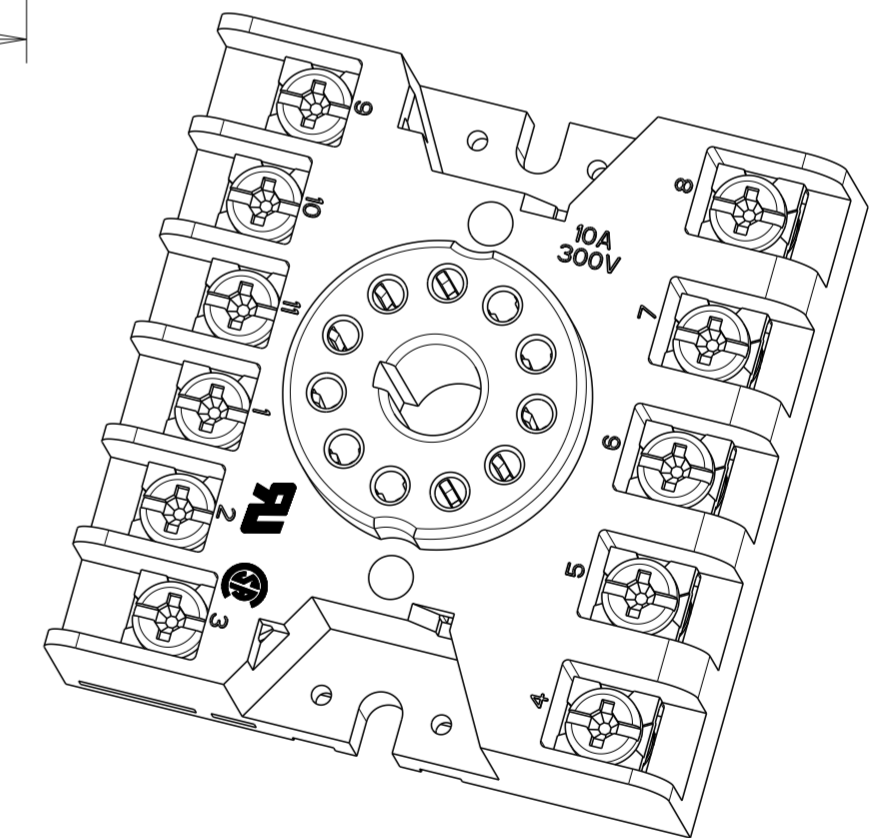
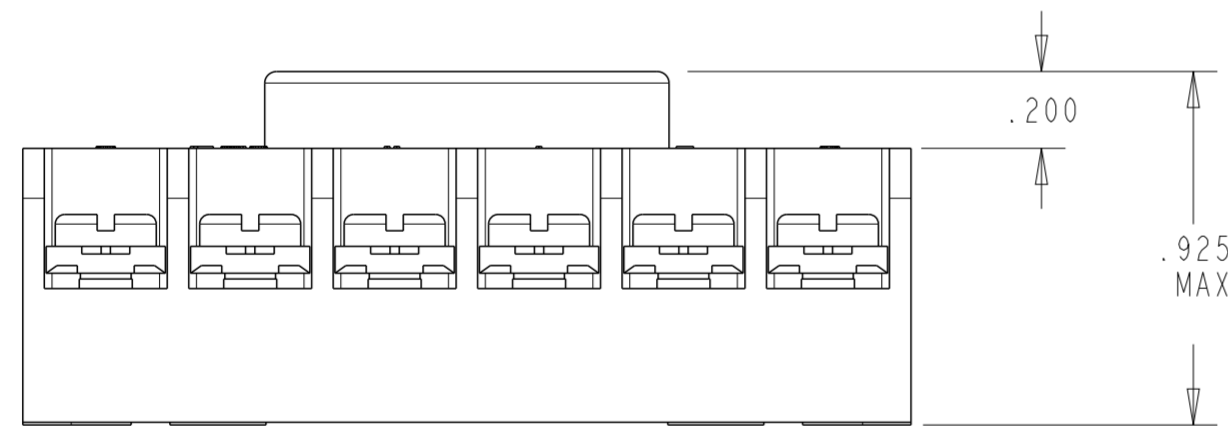

SCALE 3:2

NOTES: UNLESS OTHERWISE SPECIFIED.

- RATINGS: 300V, 10 AMPS.
- RECOMMENDED INSTALLATION TORQUE FOR #6-32 SCREW TERMINALS IS 7.5 IN-LB.
- SCREW TERMINALS ACCEPT UP TO TWO #12 AWG WIRES.

4 MATERIAL:
 SOCKET BODY AND COVER: PBT 30% GLASS REINFORCED.
 SCREW & CAPTIVE WASHER: STEEL WITH ZINC PLATING.

THIS DRAWING IS A CONTROLLED DOCUMENT.

DIMENSIONS:	TOLERANCES UNLESS OTHERWISE SPECIFIED:
in	0 PLC ±-
	1 PLC ±.1
	2 PLC ±.02
	3 PLC ±.005
	4 PLC ±.0005
	ANGLES ±-
	FINISH ±-
MATERIAL	
-	-
-	-

DWN	I. SALAZAR	29APR2024
CHK	R. JIMENEZ	29APR2024
APVD	R. JIMENEZ	29APR2024
PRODUCT SPEC	-	-
APPLICATION SPEC	-	-
WEIGHT	-	-
CUSTOMER DRAWING	SCALE 2:1	SHEET 1 OF 1

TE CONNECTIVITY PART NUMBER: 1393143-7



NAME: SOCKET, KRP, 11, SCW, PLE
 KR 11 PIN OCTAL, SCREW,
 SURFACE MOUNT

SIZE	CAGE CODE	DRAWING NO	RESTRICTED TO
A2	00779	C-27E123	-
REV	A		