

REVISIONS				
P.	LTN	DESCRIPTION	DATE	APVD
A		INITIAL RELEASE	8DEC2020	RY SH

NOTES, UNLESS OTHERWISE SPECIFIED
 1. MATERIAL:
 HOUSING - THERMOPLASTIC, GLASS PREINFORCED, COLOR, BLACK, UL 94V-0
 CONTACTS- COPPER ALLOY.
 2. FINISH:
 MATING AREA - 30u" GOLD OR 30u" PALLADIUM NICKEL+GOLD PLATED OVER NICKEL
 SOLDER TAIL - MATTE TIN OVER NICKEL.
 3. MARK P/N AND DATA CODE IN APPROX. AREA AS SHOWN.

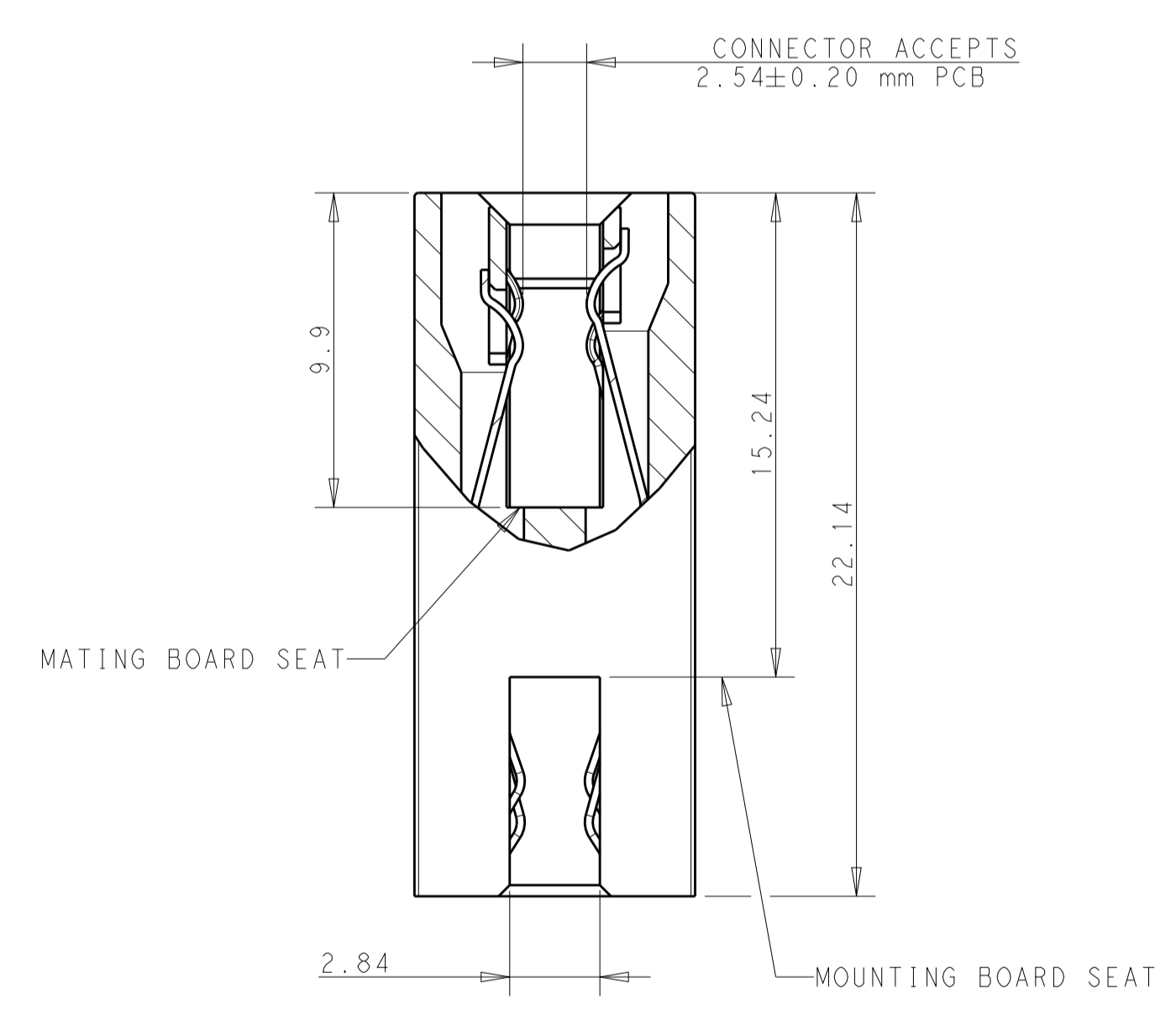
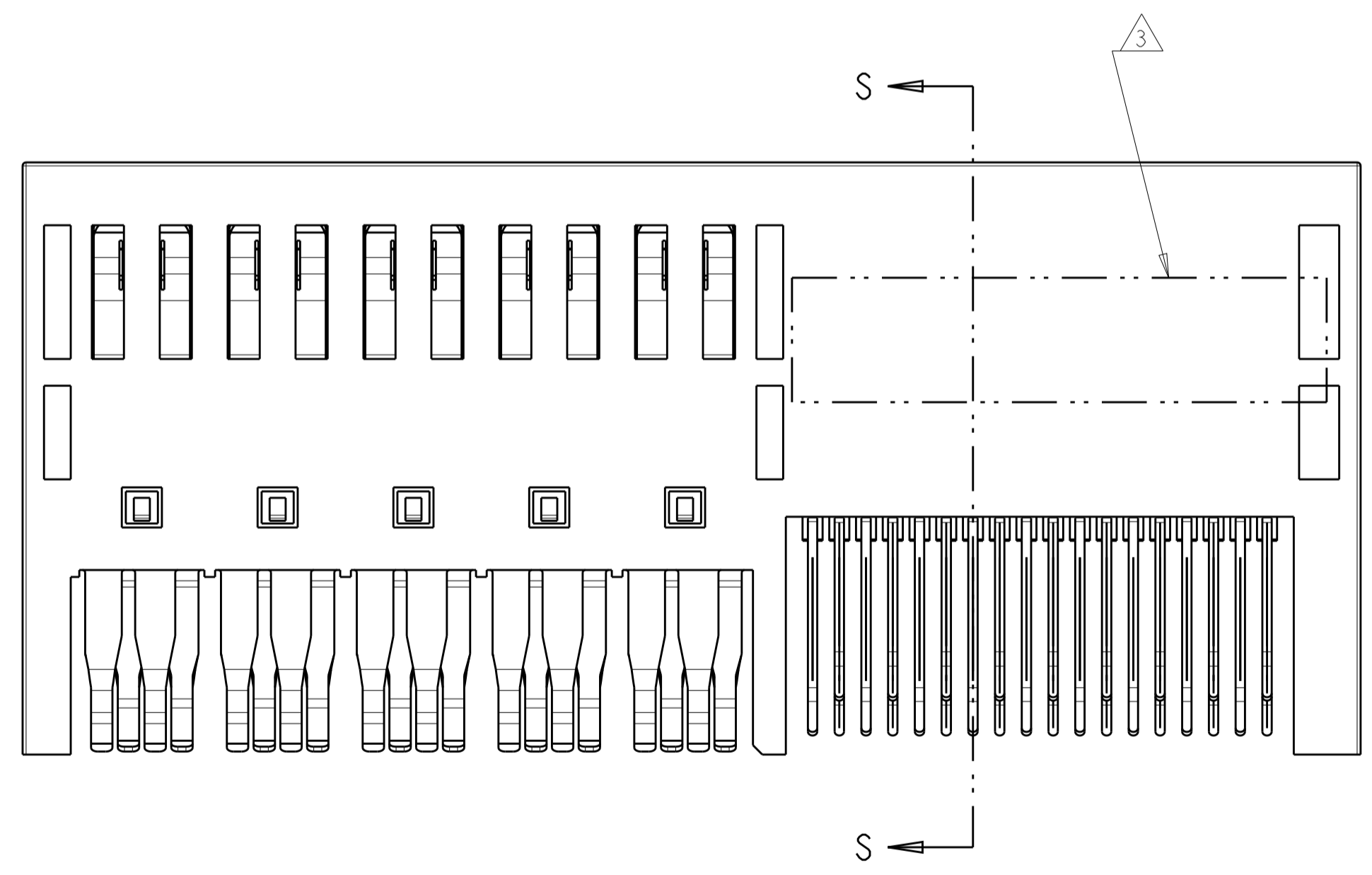
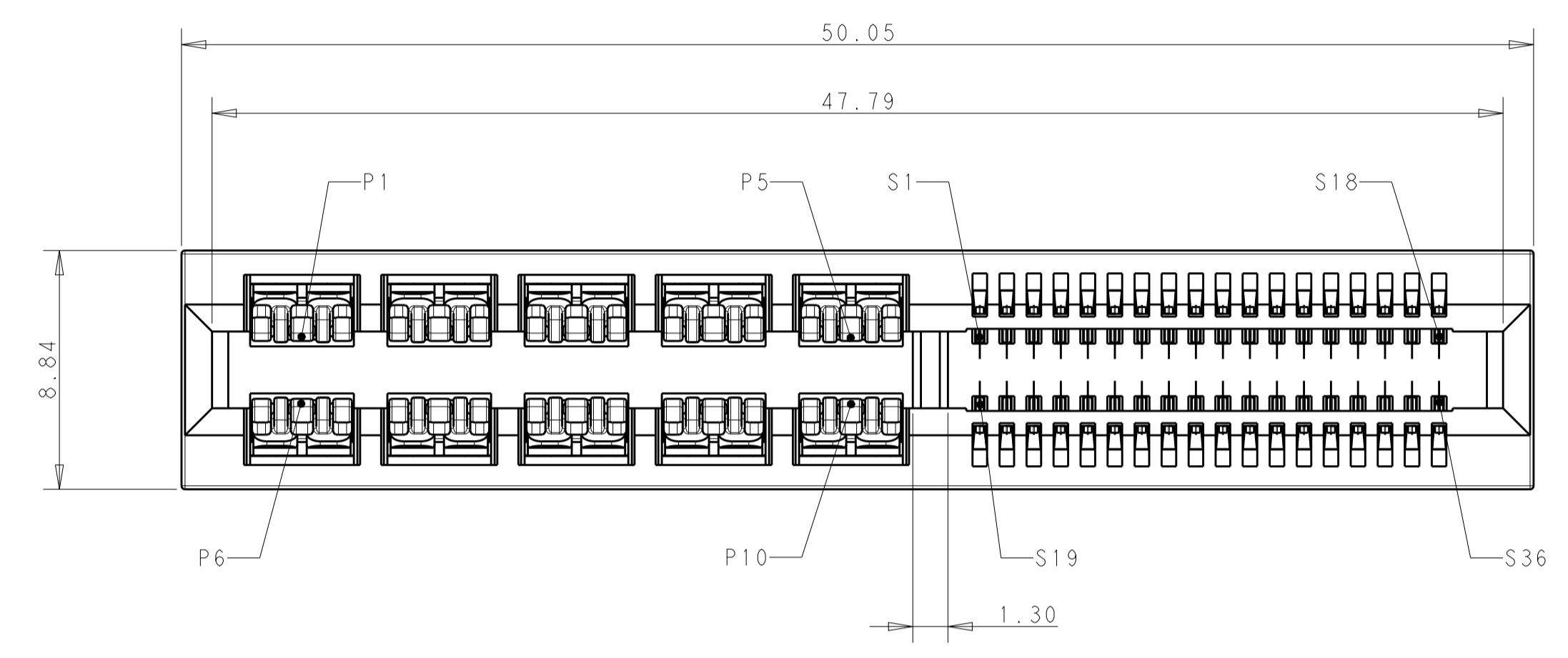

SECTION S-S

PART NUMBER 2371744-1

THIS DRAWING IS A CONTROLLED DOCUMENT.		OWN RICHARD YU	8DEC2020	TE Connectivity	
DIMENSIONS: mm		CHK -	APVD SEAN HAN		
TOLERANCES UNLESS OTHERWISE SPECIFIED:		PRODUCT SPEC		NAME HD+ CARD EDGE STRADDLE MOUNT	
0 PLC ±.50		APPLICATION SPEC		2P DESIGN, 2X5P-2X18S	
1 PLC ±0.25		SIZE		CAGE CODE DRAWING NO	
2 PLC ±.25		A100779		C=2371744	
3 PLC ±.25		RESTRICTED TO		-	
4 PLC ±.25		WEIGHT		-	
ANGLES ±.2°		CUSTOMER DRAWING		SCALE 5:1 SHEET 1 OF 2 REV A	
FINISH		MATERIAL TBD			

REVISIONS				
P.	LTN.	DESCRIPTION	DATE	APVD.
-	-	SEE SHEET 1	-	-

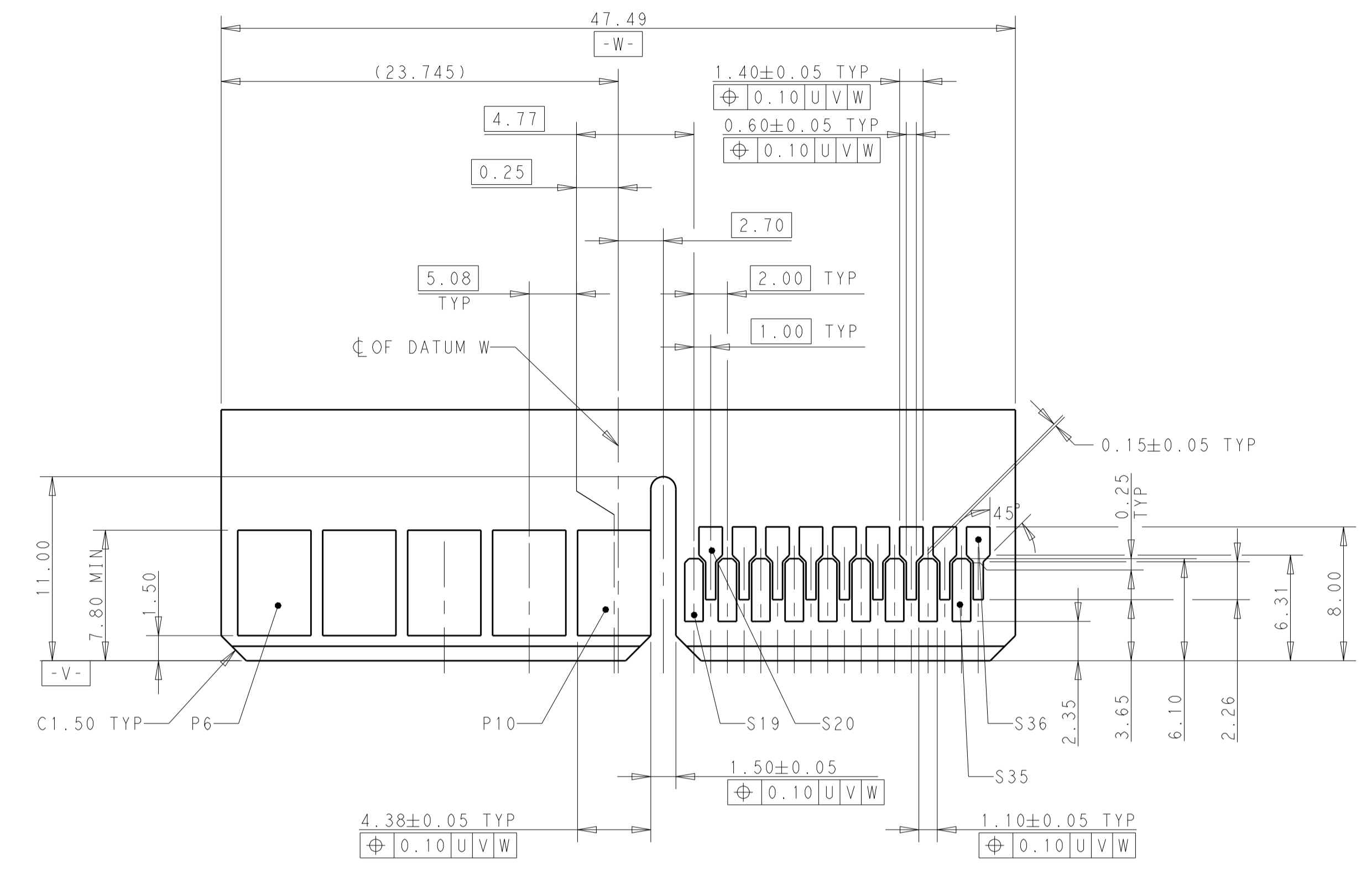

RECOMMENDED MATING BOARD EDGE CONFIGURATION (PRIMARY SIDE SHOWN)

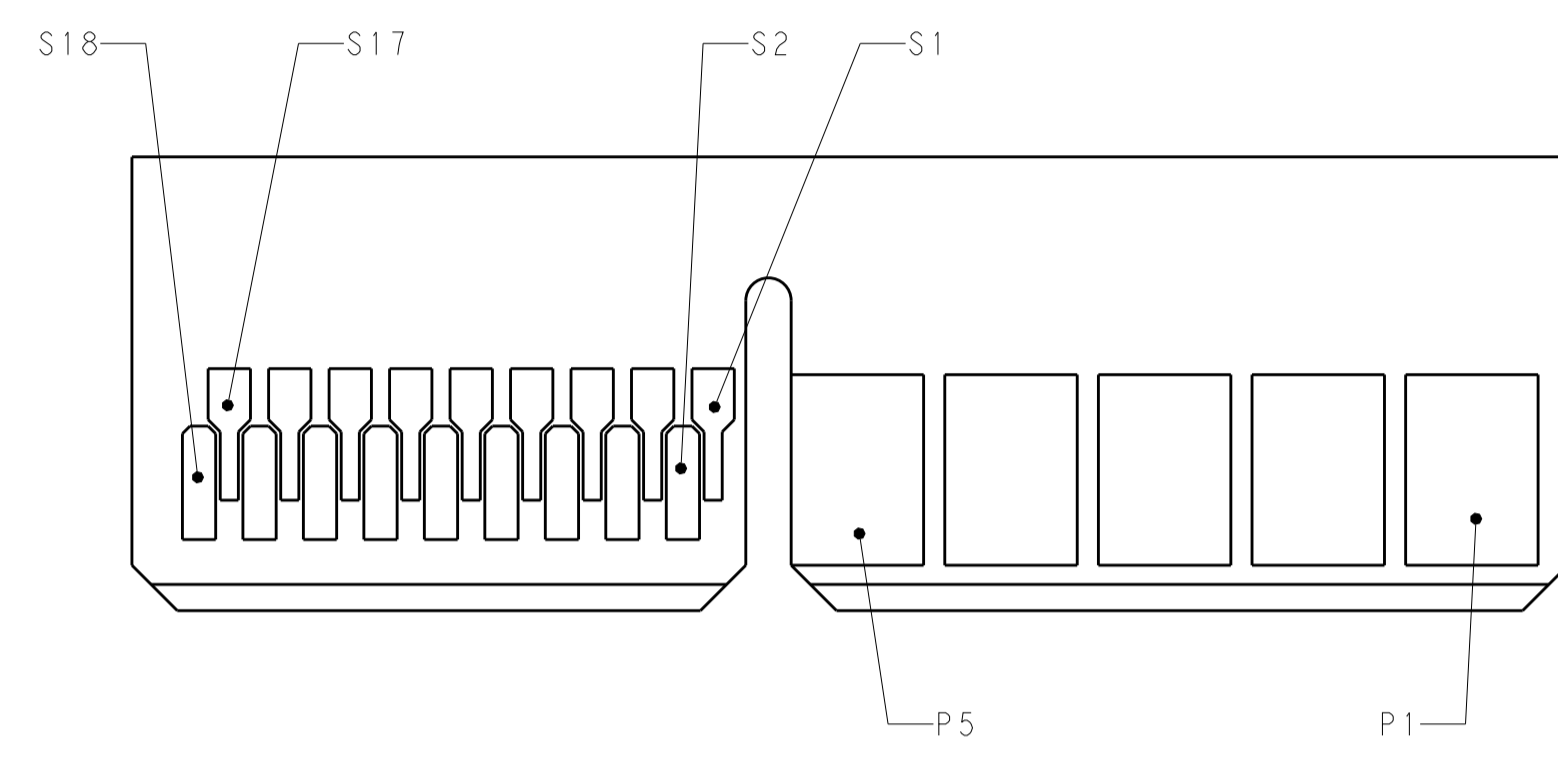
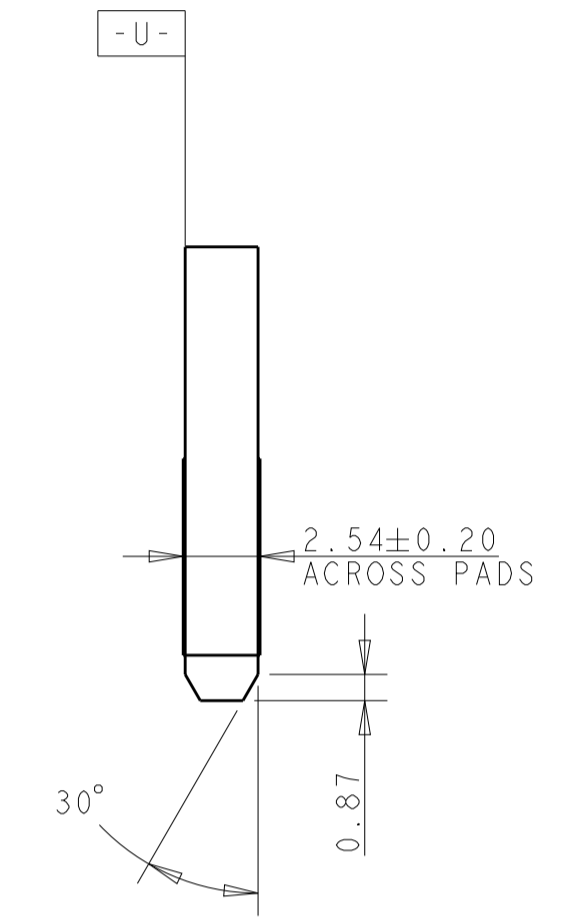

RECOMMENDED MATING BOARD EDGE CONFIGURATION (SECONDARY SIDE SHOWN)

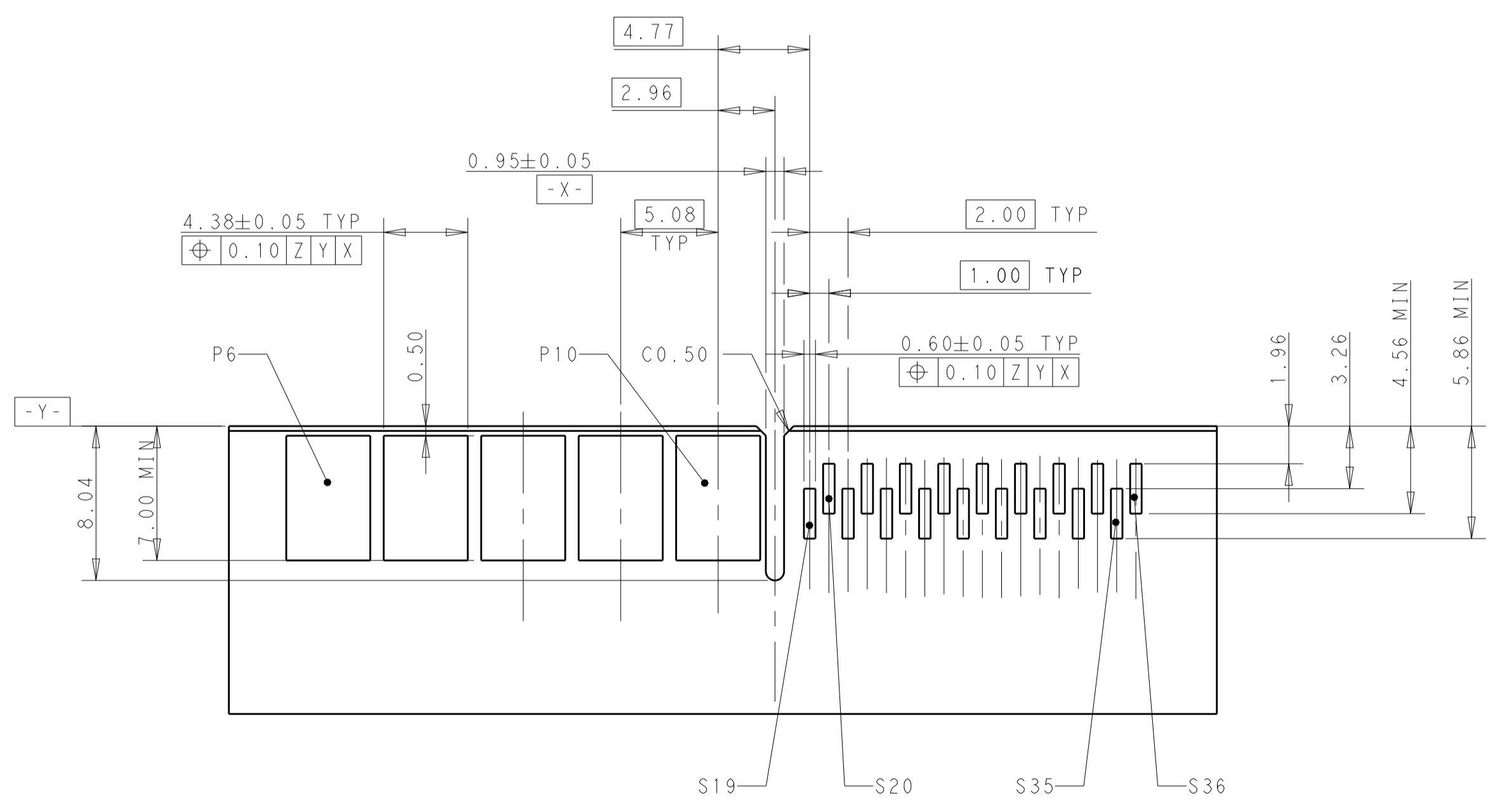

RECOMMENDED MOUNTING BOARD EDGE CONFIGURATION (PRIMARY SIDE SHOWN)

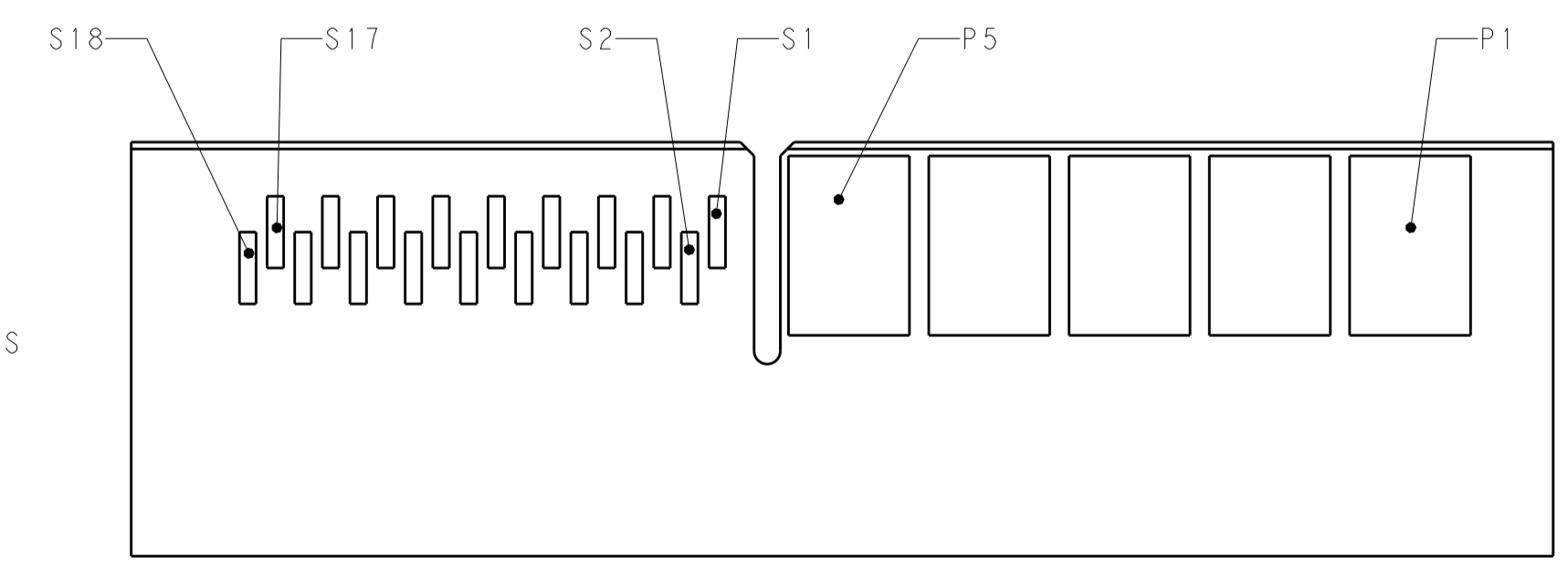
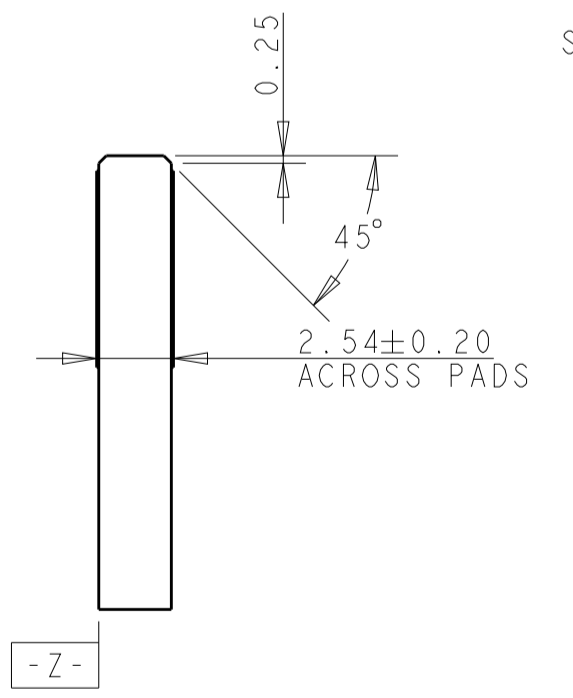

RECOMMENDED MOUNTING BOARD EDGE CONFIGURATION (SECONDARY SIDE SHOWN)

THIS DRAWING IS A CONTROLLED DOCUMENT.		OWN: RICHARD YU	8DEC2020	TE Connectivity
DIMENSIONS: mm		CHK: -	-	
TOLERANCES UNLESS OTHERWISE SPECIFIED:		APVD: SEAN HAN	8DEC2020	NAME: HD+ CARD EDGE STRADDLE MOUNT PRODUCT SPEC: 2P DESIGN, 2X5P-2X18S
0 PLC ± 1 PLC ±0.20 2 PLC ±0.10 3 PLC ± 4 PLC ± ANGLES ±2°		PRODUCT SPEC: -	APPLICATION SPEC: -	
MATERIAL: TBD	FINISH: -	WEIGHT: -	SIZE: A100779	RESTRICTED TO: -
CUSTOMER DRAWING		SCALE: 5:1	SHEET: 2 OF 2	REV: A