

REVISIONS					
P	LTR	DESCRIPTION	DATE	DWN	APVD
1		NEW DRAWING	27MAR2024	LP	MY

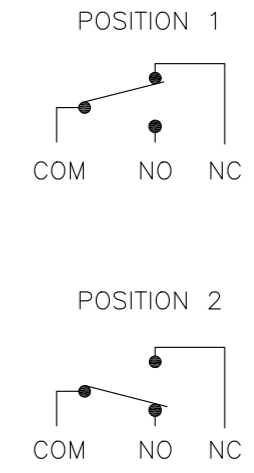
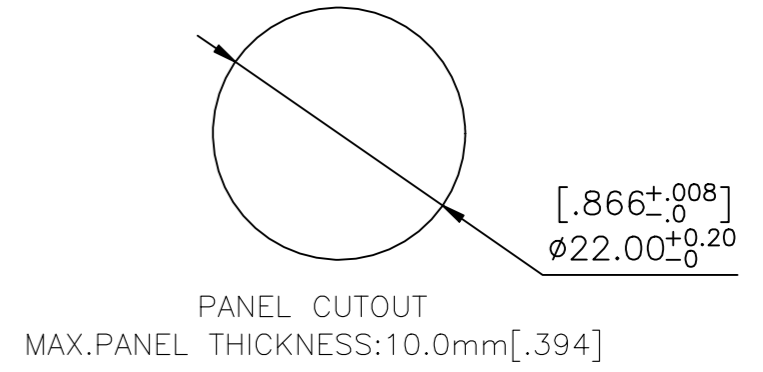
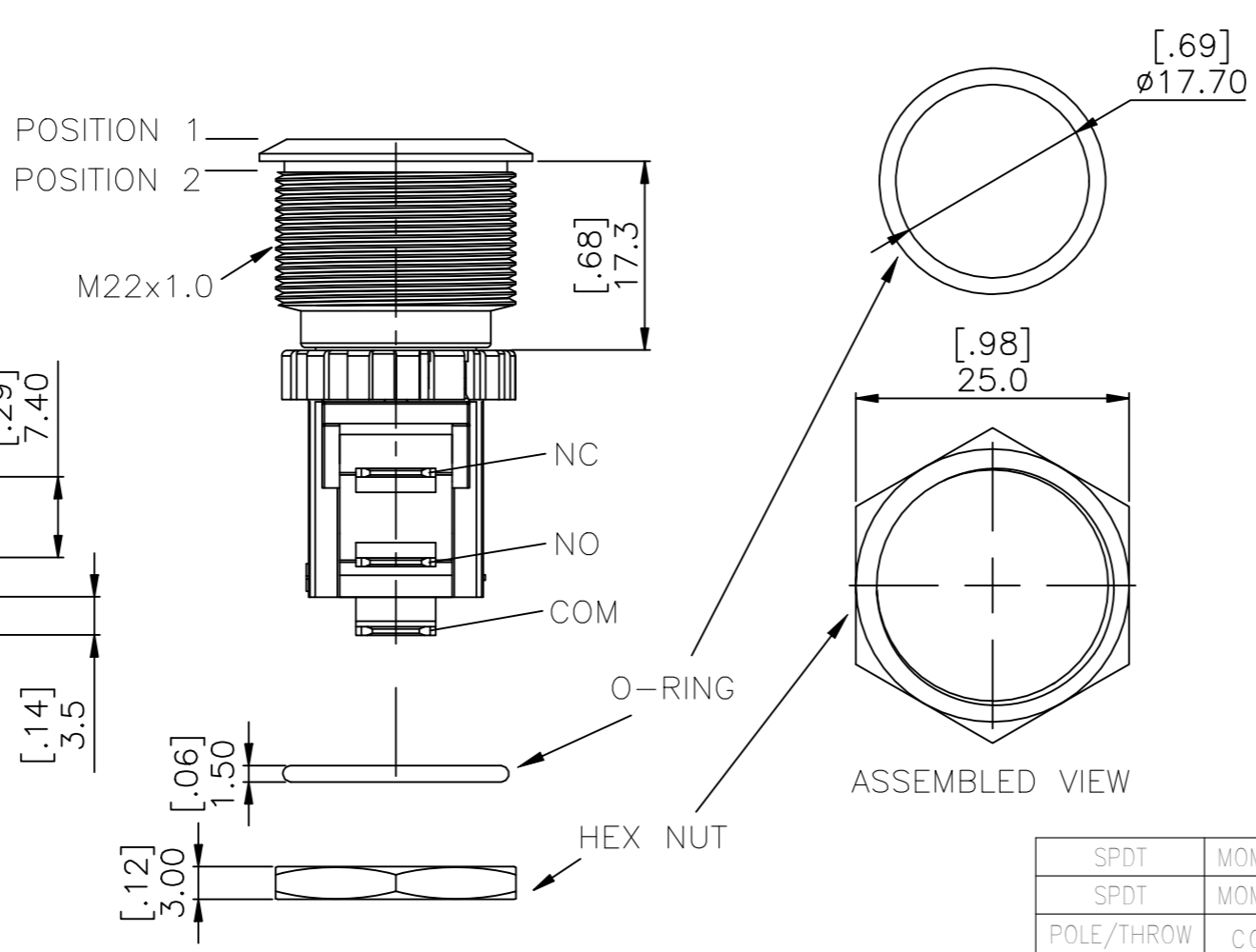
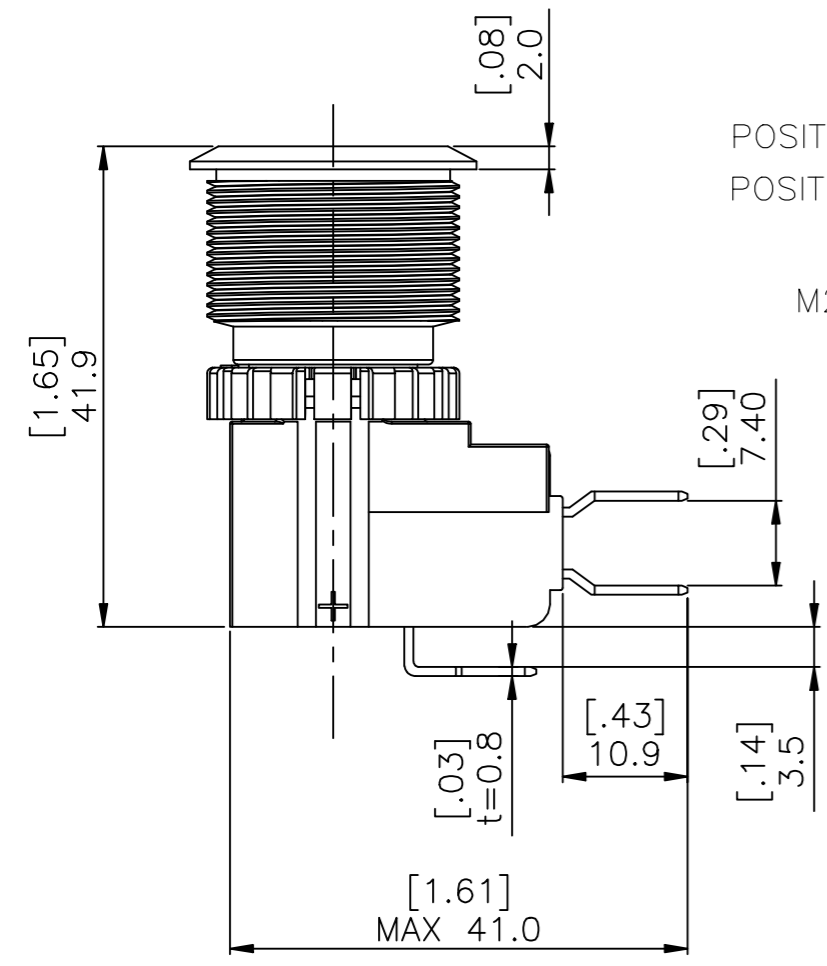
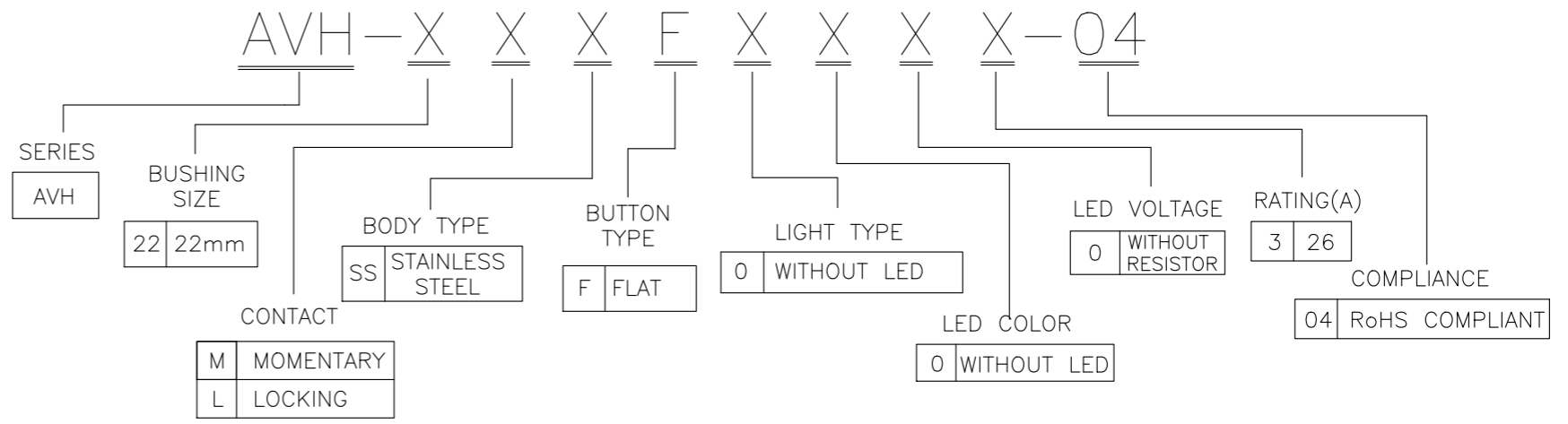
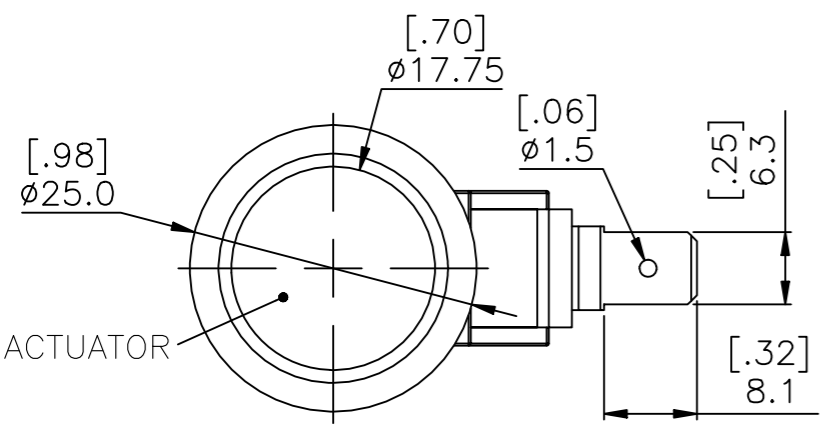

SPDT	MOMENTARY	No LED	No LED	AVH22LSSF0002604	2364685-2	2
SPDT	MOMENTARY	No LED	No LED	AVH22MSSF0002604	2364685-1	1
POLE/THROW	CONTACT	LED COLOR	LED VOLTAGE	TE SMART P/N	TE P/N	SL No.

THIS DRAWING IS A CONTROLLED DOCUMENT.

DIMENSIONS:	TOLERANCES UNLESS OTHERWISE SPECIFIED:
mm [INCHES]	
	0 PLC ± -
	1 PLC ± -
	2 PLC ± -
	3 PLC ± -
	4 PLC ± -
	ANGLES ± -
MATERIAL	FINISH
-	-

DWN LINGANATHAN P 27MAR2024		APVD MANOJ YADAV 27MAR2024		NAME	
CHK MANOJ YADAV 27MAR2024		PRODUCT SPEC		AVH22 FLT SS	
APPLICATION SPEC		SIZE		CAGE CODE	
-		A3		00779	
WEIGHT		DRAWING NO		RESTRICTED TO	
-		C-2364685		-	
CUSTOMER DRAWING			SCALE	SHEET	REV
			1:1	1 OF 2	1

REVISIONS					
P	LTR	DESCRIPTION	DATE	DWN	APVD
-	-	SEE SHEET 1	-	-	-

SPECIFICATIONS

- 1.CONTACT MATERIAL: SILVER
- 2.RATING: 26A 250/125VAC.
- 3.ELECTRICAL LIFE: 26A/125&250VAC 10,000 CYCLES
- 4.MECHANICAL LIFE: Momentary 1,000,000.
- 5.INSULATION RESISTANCE:100MΩ MIN AT 500VDC.
- 6.DIELECTRIC STRENGTH: 1,500V RMS@sea level.
- 7.CONTACT RESISTANCE: 50mΩ MAX. @1A 12VDC(initial value).
- 8.OPERATING TEMPERATURE: -25°C to 85 C
- 9.TRAVEL: ABOUT 3.2mm.
- 10.OPERATION PRESSURE: 3.5±1.5N
11. INGRESS PROTECTION: IP67, IK08(Stainless Steel).
12. TORQUE: 1~3Nm.

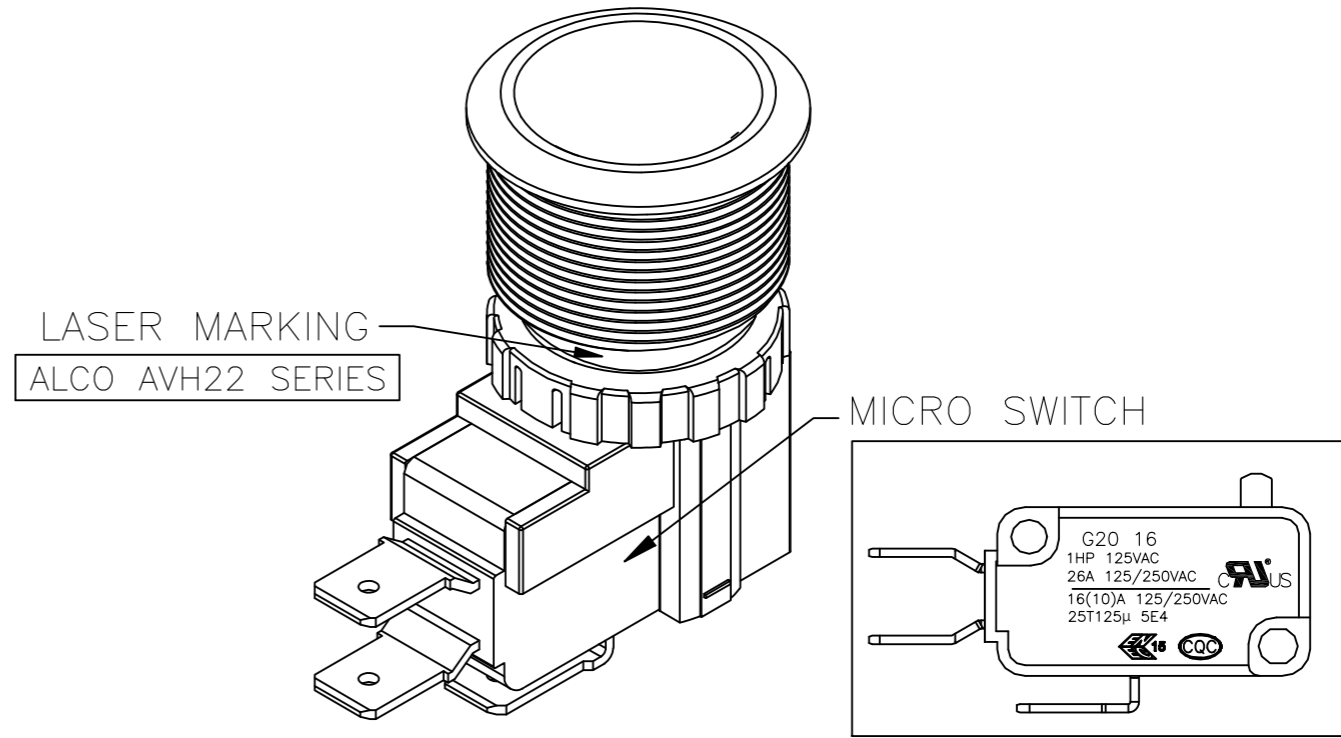

MATERIAL:
 BUSHING: Stainless Steel.
 BASE: PBT(UL 94-V0); PC(UL94-V2); PA6T(UL94-V0)
 ACTUATOR: PC(UL94-V2); Stainless Steel.
 INNER ASSEMBLY: POM/PA66
 SPRING: Steel.
 SEALING: Silicone.
 O-Ring: Silicone.
 TERMINAL/CONTACT: Brass, Silver plated.
 HEX NUT: Nickel plated brass.
 RoHS

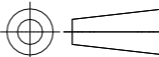
THIS DRAWING IS A CONTROLLED DOCUMENT.		DWN LINGANATHAN P 27MAR2024	 TE Connectivity Ltd.		
		CHK MANOJ YADAV 27MAR2024			
DIMENSIONS: mm [INCHES]		APVD MANOJ YADAV 27MAR2024	NAME AVH22 FLT SS		
		PRODUCT SPEC -	-		
TOLERANCES UNLESS OTHERWISE SPECIFIED: 0 PLC ± - 1 PLC ± - 2 PLC ± - 3 PLC ± - 4 PLC ± - ANGLES ± -		APPLICATION SPEC -	SIZE A3	CAGE CODE 00779	DRAWING NO C-2364685
MATERIAL -		FINISH -	WEIGHT -	RESTRICTED TO -	
CUSTOMER DRAWING			SCALE 1:1	SHEET 2 OF 2	REV 1