

P	LTR	DESCRIPTION	DATE	DWN	APVD
	A	RELEASED TO PRODUCTION	26NOV2020	SM	MZ
	A1	2359527-3 P/N ADDED FOR 18AWG	02JUN2021	SM	MZ
	A2	18AWG RELEASED FOR PRODUCTION	28JAN2022	DM	SM
	A3	RELEASED	18MAR2022	SM	MZ

P/N 2359527-1

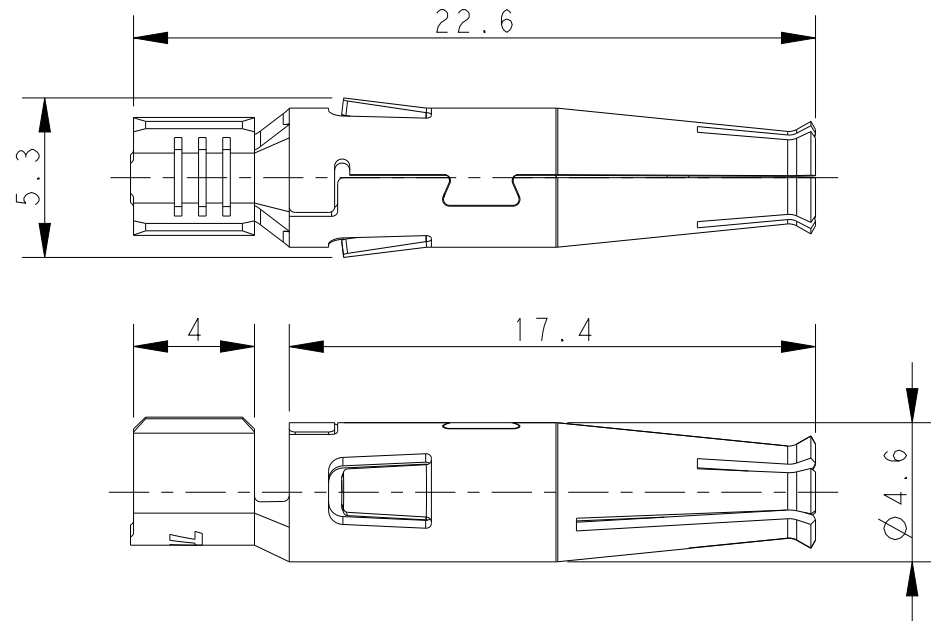

NOTES:

- MATERIAL: COPPER ALLOY, TEMPER >520 MPa  
FINISH : BRIGHT TIN
- OPERATING RATINGS:  
VOLTAGE (max): 600Vac Max  
CURRENT (max): 25A ON 4.0mm<sup>2</sup> & 20A ON 12AWG  
TEMPERATURE : -40°C TO 85°C
- FOR ASSEMBLY & CRIMP INSTRUCTIONS, REFER APPLICATION SPECIFICATION 114-133123
- PACKAGING: CONTACTS ON REEL

P/N 2359527-2

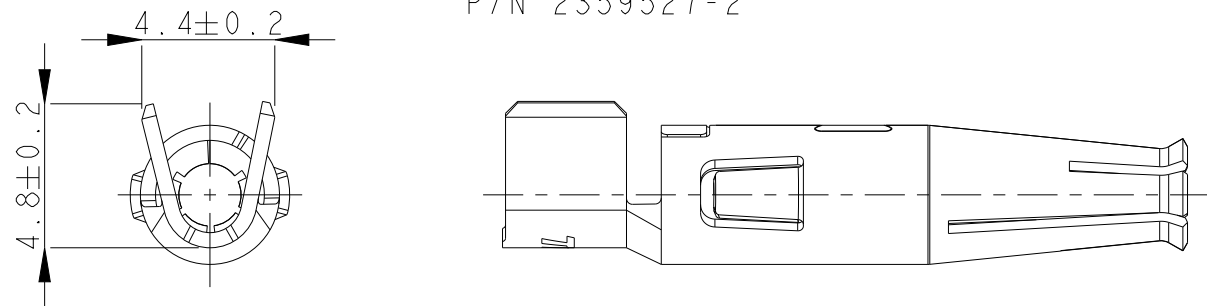

P/N 2359527-3

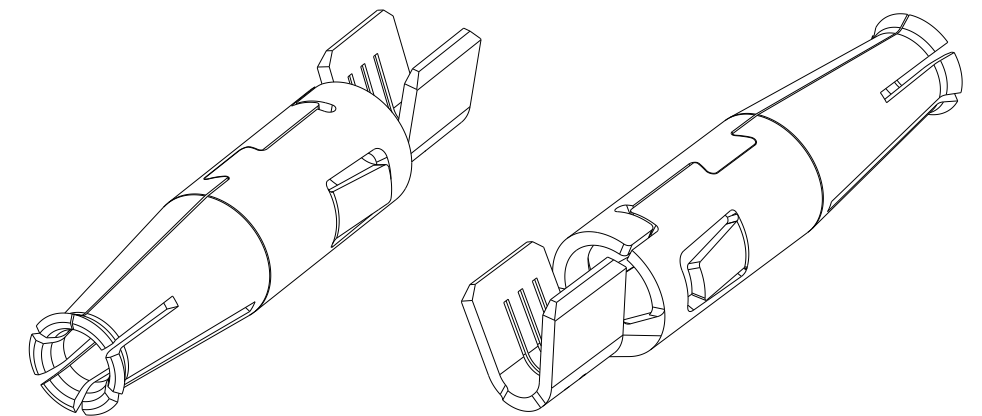
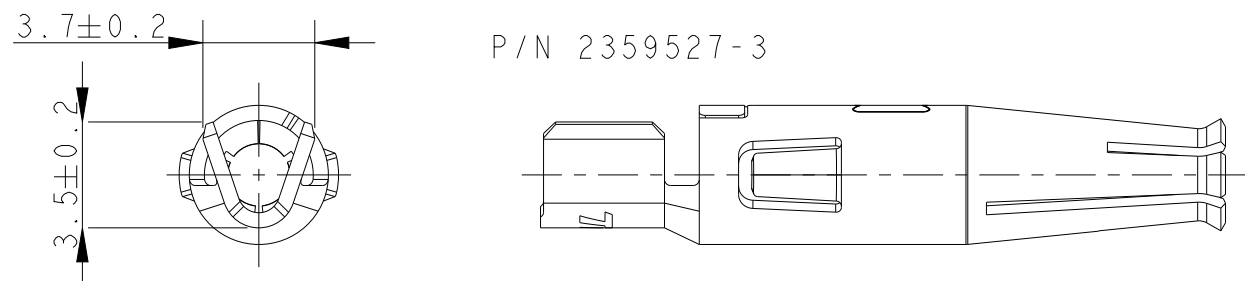

CONTACTS SUPPLIED ON REEL  
PITCH BETWEEN TWO CONTACTS: 15.0

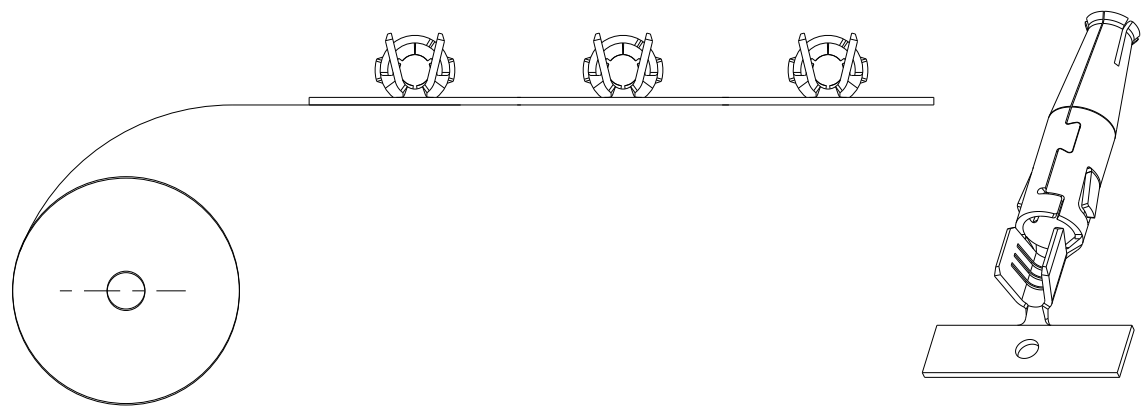

CRIMP SOCKET CONTACT	18 AWG	2359527-3
	4.0 (12 AWG)	2359527-2
	1.5-2.5 (16-14 AWG)	2359527-1
DESCRIPTION	WIRE SIZE mm <sup>2</sup> (AWG)	PART NUMBER

THIS DRAWING IS A CONTROLLED DOCUMENT.

DIMENSIONS:	TOLERANCES UNLESS OTHERWISE SPECIFIED:
mm	
0 PLC	±0.2
1 PLC	±0.1
2 PLC	±0.05
3 PLC	±
4 PLC	±
ANGLES	±1°
MATERIAL	FINISH
SEE NOTES	SEE NOTES

DWN	20AUG2020
CHK	03SEP2020
APVD	26NOV2020
PRODUCT SPEC	108-133123
APPLICATION SPEC	114-133123
WEIGHT	-
CUSTOMER DRAWING	

TE Connectivity			
NAME			
NECTOR T, CRIMP SOCKET CONTACT			
SIZE	CAGE CODE	DRAWING NO	RESTRICTED TO
A3	00779	C-2359527	-
SCALE		SHEET	REV
4:1		1 OF 1	A3