

®

Thermofit Molded Parts

Specification Control Drawing

LIMITED DISTRIBUTION

Part Number : 234A011 thru 052-XX-08

Description : Boot, Rectangular,
Subminiature, 90° End Entry

NOTES

All dimensions are in $\frac{\text{Inches}}{\text{[millimeters]}}$

Dimensions appearing in table are as follows:

a - As Supplied

b - After Unrestricted Recovery

Coating is optional. As supplied dimensions appearing in table are for uncoated parts. When coating is added, entry diameters will be reduced by .06 max.

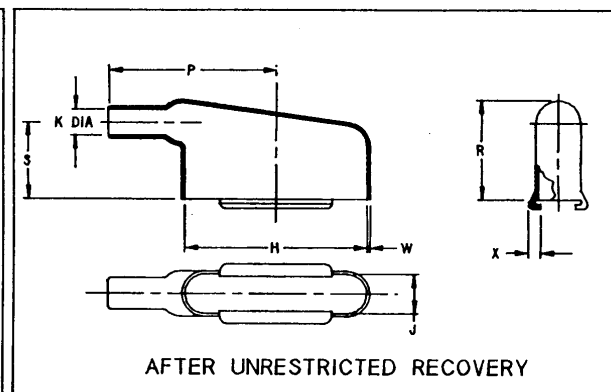
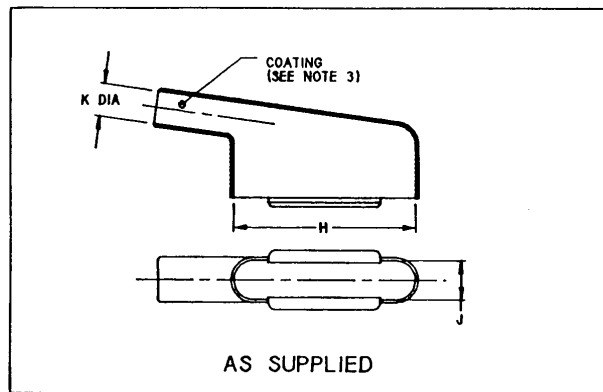

TABLE OF DIMENSIONS

PART NUMBER	H		J		K		P ±10%	R ±10%	S ±10%	W ±20%	X ±20%
	Min a	±5% b	Min a	±5% b	Min a	Max b					
234A011-XX-08	$\frac{.91}{[23.1]}$	$\frac{.80}{[20.3]}$	$\frac{.71}{[18.0]}$	$\frac{.42}{[10.7]}$	$\frac{.35}{[8.9]}$	$\frac{.16}{[4.1]}$	$\frac{1.02}{[25.9]}$	$\frac{.85}{[21.6]}$	$\frac{.60}{[15.2]}$	$\frac{.04}{[1.0]}$	$\frac{.12}{[3.0]}$
234A021-XX-08	$\frac{1.26}{[32.0]}$	$\frac{1.11}{[28.2]}$	$\frac{.71}{[18.0]}$	$\frac{.42}{[10.7]}$	$\frac{.43}{[10.9]}$	$\frac{.21}{[5.3]}$	$\frac{1.21}{[30.1]}$	$\frac{.97}{[24.6]}$	$\frac{.73}{[18.5]}$	$\frac{.04}{[1.0]}$	$\frac{.12}{[3.0]}$
234A032-XX-08	$\frac{1.77}{[45.0]}$	$\frac{1.66}{[42.2]}$	$\frac{.71}{[18.0]}$	$\frac{.42}{[10.7]}$	$\frac{.59}{[15.0]}$	$\frac{.29}{[7.4]}$	$\frac{1.69}{[43.0]}$	$\frac{1.10}{[27.9]}$	$\frac{.87}{[22.1]}$	$\frac{.04}{[1.0]}$	$\frac{.12}{[3.0]}$
234A042-XX-08	$\frac{2.52}{[64.0]}$	$\frac{2.31}{[58.7]}$	$\frac{.71}{[18.0]}$	$\frac{.42}{[10.7]}$	$\frac{.74}{[18.8]}$	$\frac{.34}{[8.6]}$	$\frac{2.10}{[53.3]}$	$\frac{1.20}{[30.5]}$	$\frac{1.00}{[25.4]}$	$\frac{.04}{[1.0]}$	$\frac{.12}{[3.0]}$
234A052-XX-08	$\frac{2.52}{[64.0]}$	$\frac{2.28}{[58.0]}$	$\frac{.83}{[21.1]}$	$\frac{.54}{[13.7]}$	$\frac{.83}{[21.1]}$	$\frac{.42}{[10.7]}$	$\frac{2.20}{[59.9]}$	$\frac{1.27}{[32.3]}$	$\frac{1.00}{[25.4]}$	$\frac{.04}{[1.0]}$	$\frac{.12}{[3.0]}$

If this document is printed it becomes uncontrolled.
Check for the latest revision.

Revision : A

Date : 10/18/90

Part Number : 234A011 thru 052-XX-08

Description : Boot, Rectangular,
Subminiature, 90°. End Entry

Raychem

RAYCHEM CORPORATION
300 CONSTITUTION DRIVE
MENLO PARK, CALIFORNIA 94025
(415) 361-8055

®
Thermofit Molded Parts
Specification Control Drawing

Part Number : 234A011 thru 052-XX-08
 Description : Boot, Rectangular,
 Subminiature, 90°, End Entr

LIMITED DISTRIBUTION

COMPATABILITY CHART					
MATERIAL DASH NO.	MATERIAL DESCRIPTION	RT SPEC	COATING SLASH NO.	COATING S NO.	COATING DESCRIPTION
-3	Polyolefin, Semi-rigid	RT-301	/42	S-1017	Adhesive
-8	Polyolefin, Spacc	RT-1308			
-25	Elastomer, Fluid Resistant	RT-1325			

ORDERING INFORMATION

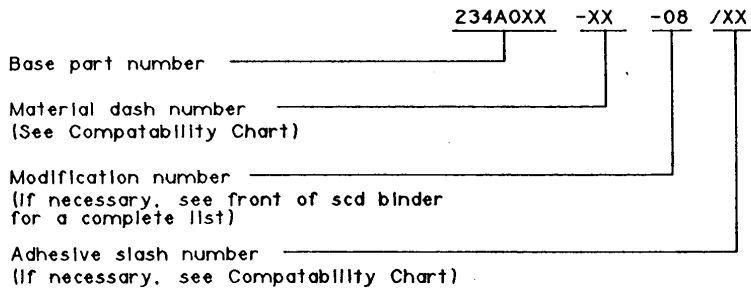

THIS DRAWING IS SUBJECT TO CHANGE WITHOUT NOTICE: CONSULT YOUR
 NEAREST FIELD REPRESENTATIVE FOR CURRENT REVISION

Raychem

RAYCHEM CORPORATION
 300 CONSTITUTION DRIVE
 MENLO PARK, CALIFORNIA 94025
 (415) 361-6055

If this document is printed it becomes uncontrolled.
 Check for the latest revision.

Revision : A
 Date : 10/18/90

Part Number : 234A011 thru 052-XX-08
 Description : Boot, Rectangular,
 Subminiature, End Entr
 CAD FILE MP8 8