

PART NUMBER	REV	MACHINE STYLE
2335600-1	C	NON CQM
2335600-2	C	WITH CQM

REVISIONS				
P	LTN	DESCRIPTION	DATE	APVD
C		RELEASED	01NOV2023	DJG VA

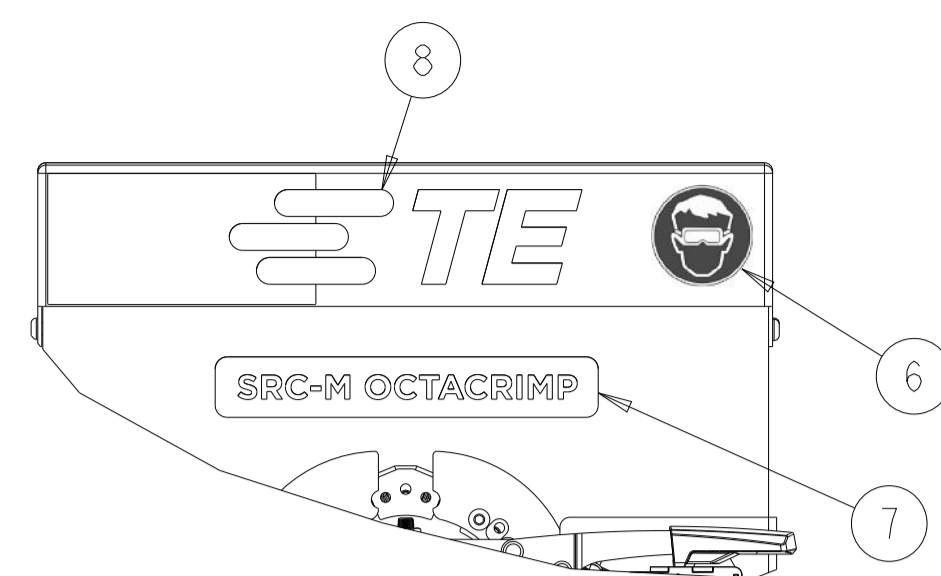

DETAIL A
SCALE 4:15

- 1. RECOMMENDED SPARE PARTS: NONE.
- △ 2. ITEM NOT SHOWN.
- △ 3. OPTIONAL CALIBRATION KIT.

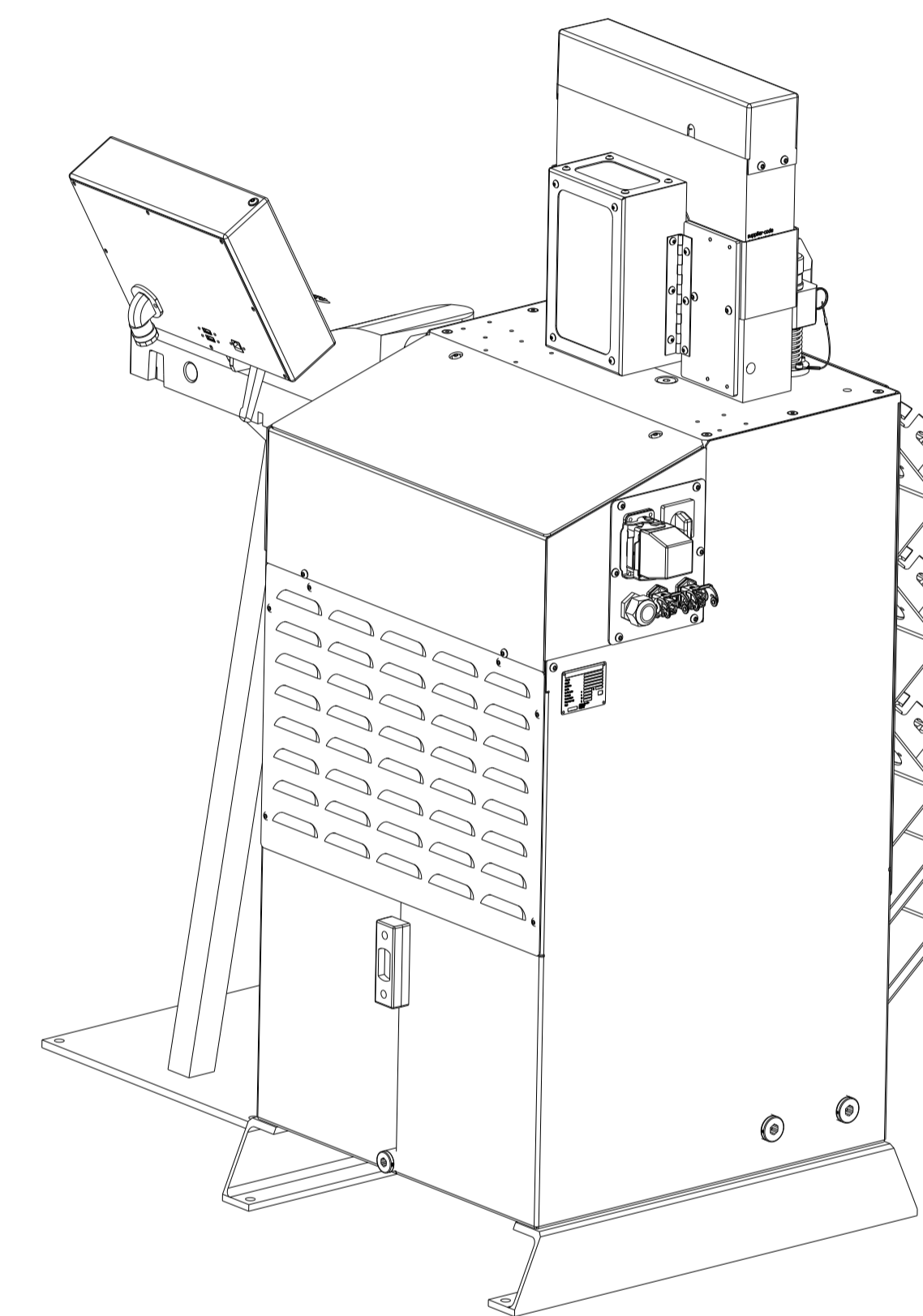
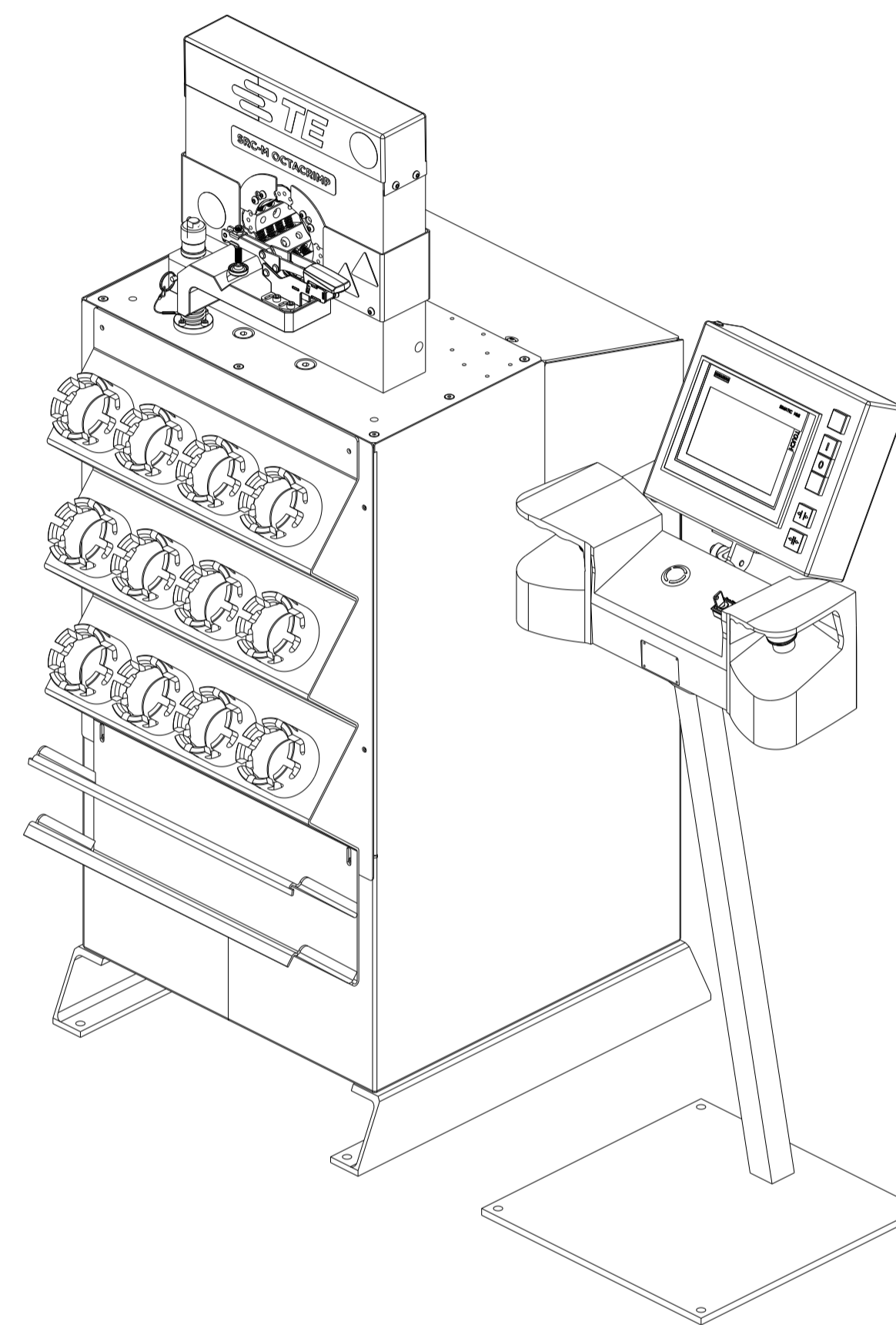
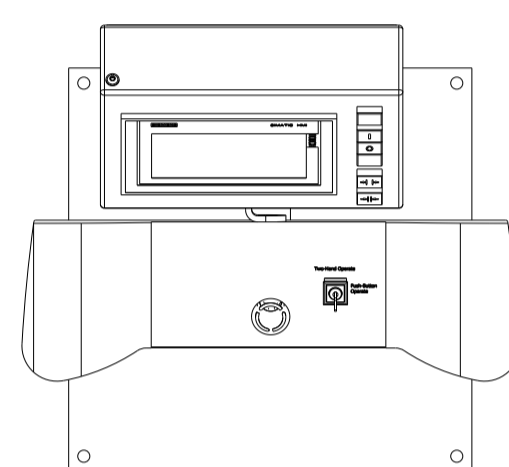
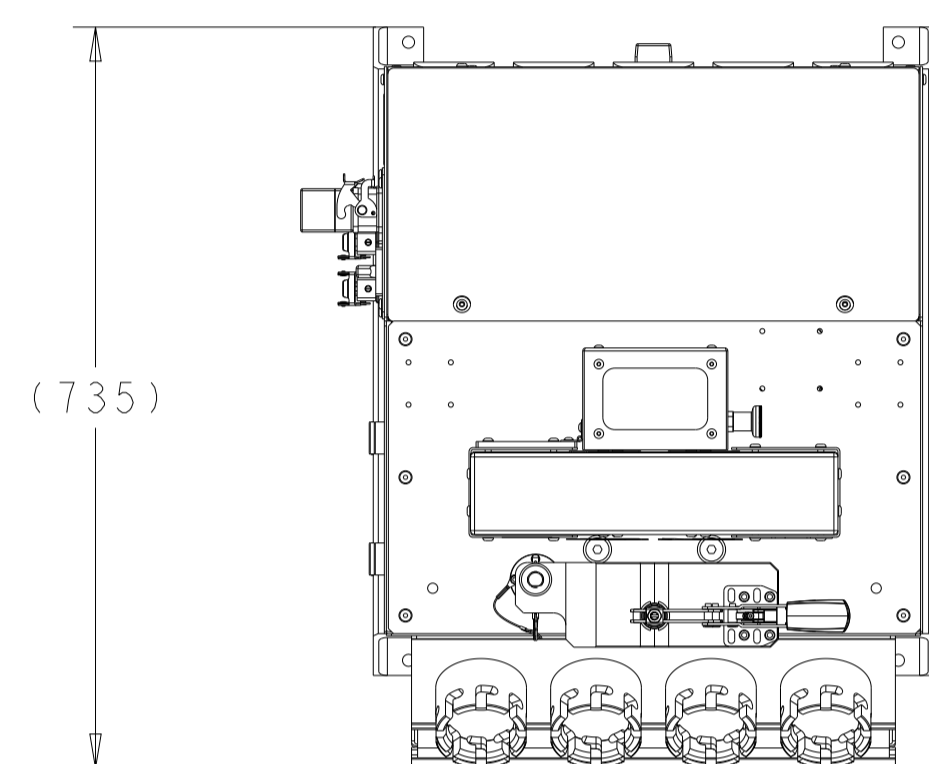

SEE DETAIL A

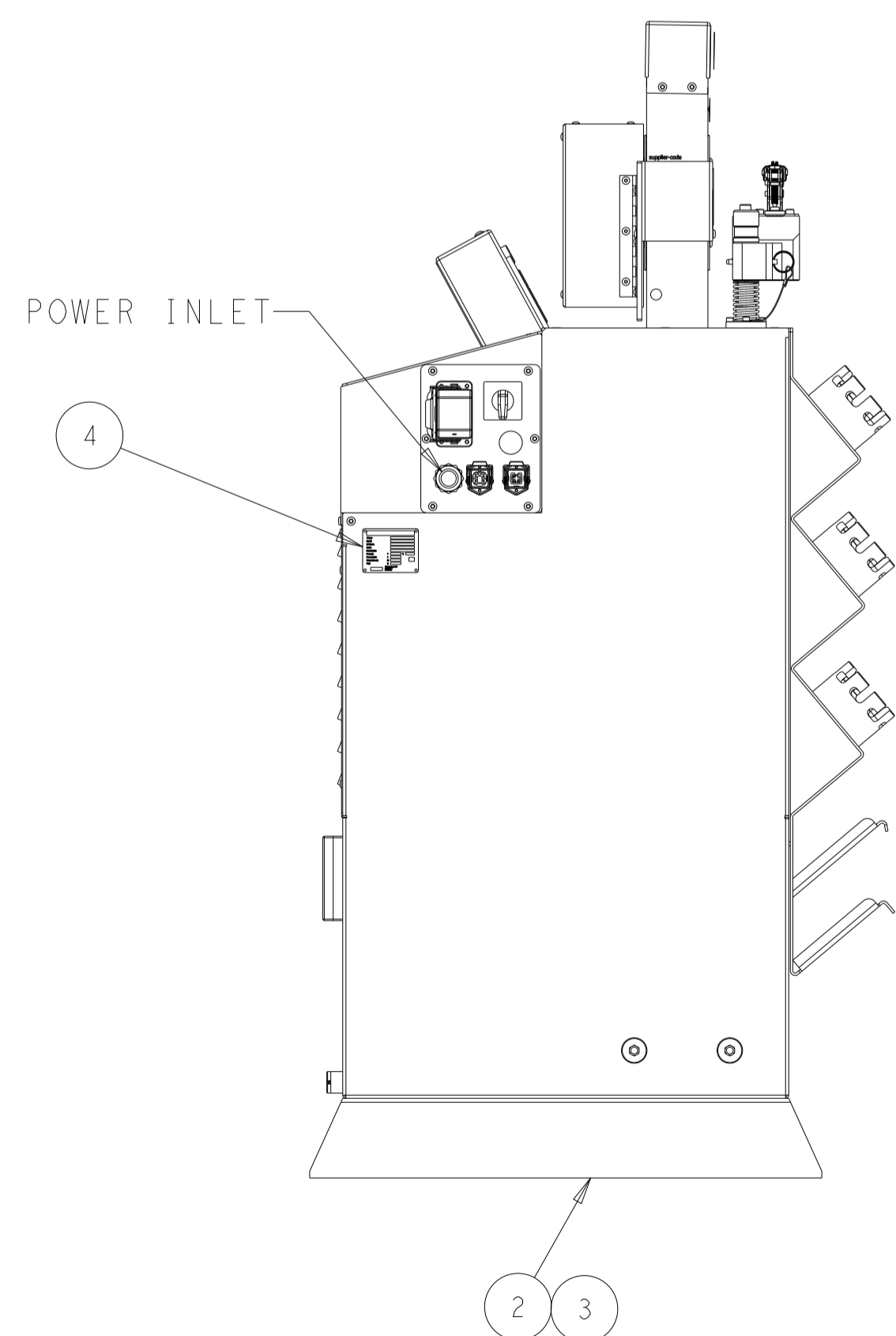
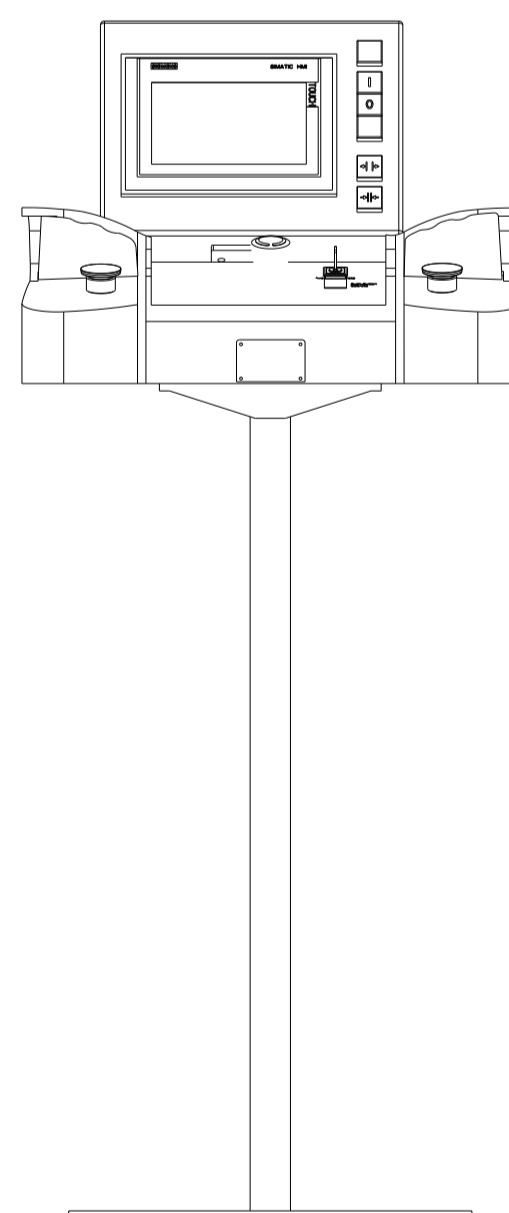
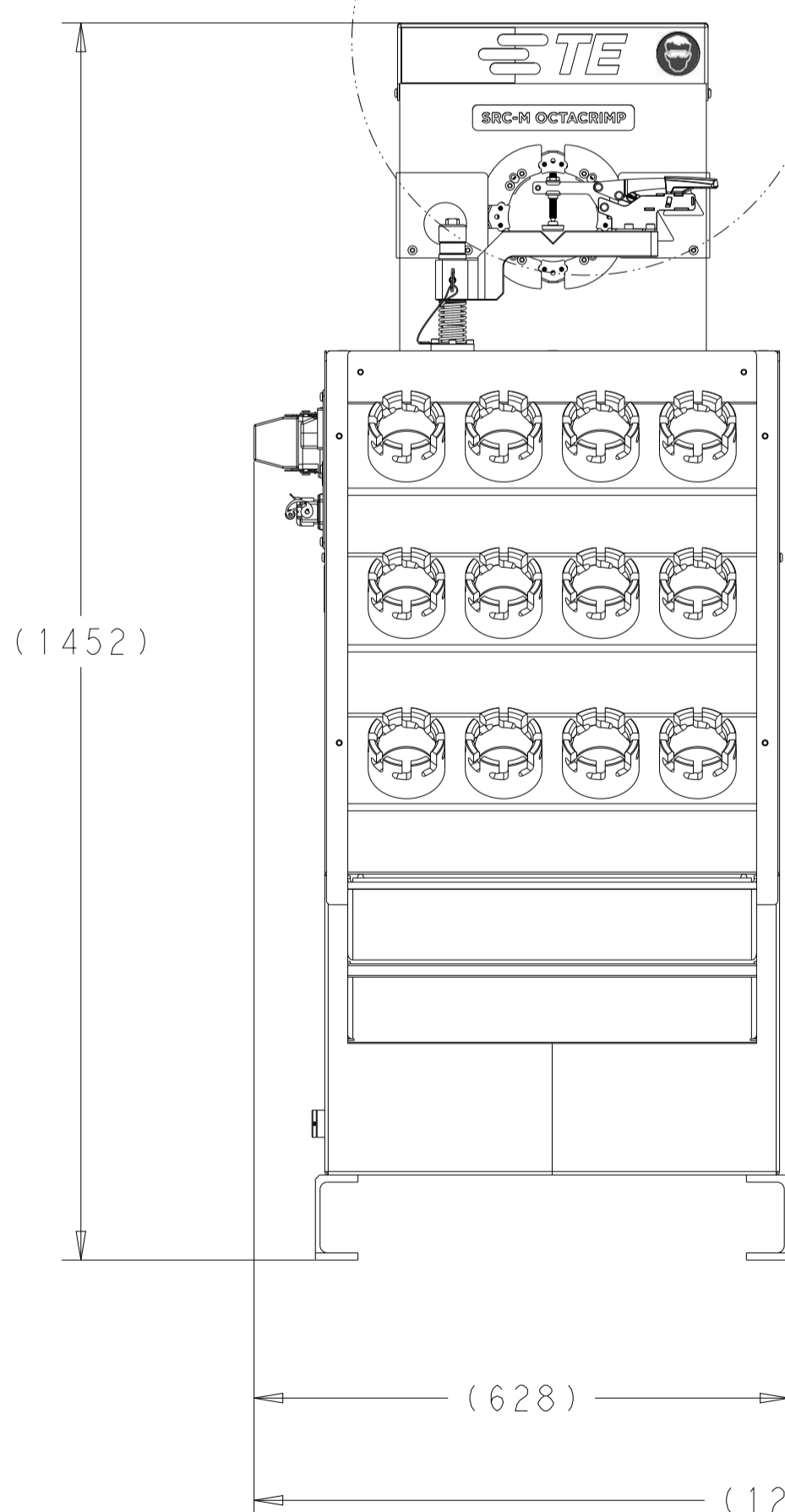

(1452)

(628)

(1259)

△ 2	REF	REF	-	2470234-1	FERRULE FITTING	14
△ 2	REF	REF	-	2470233-1	DIE SET	13
△ 2	REF	REF	-	2461011-1	DIE HOLDER	12
△ 2	REF	REF	--	2461010-1	DIE REMOVAL TOOL	11
△ 2 △ 3	REF	REF	--	2461009-1	CALIBRATION GAGE SET	10
△ 2 △ 3	REF	REF	--	2461008-1	CALIBRATION MANDREL	9
1	1	-	2-2459209-7	LABEL, TE	8	
1	1	-	2459198-1	LABEL, SRC	7	
1	1	-	2458973-1	LABEL, SAFETY EYEWARE	6	
1	1	-	7-519637-4	TYPE PLATE, MACHINES -	4	
1	-	-	2437265-1	KIT, CQM II, SRC HM220	3	
1	1	-	2448087-1	ACCESSORY KIT, RADIAL CRIMPING MACHINE	2	
-2	-1	U/M	PART NO	DESCRIPTION	ITEM NO	

THIS DRAWING IS A CONTROLLED DOCUMENT.		OWN: M. MORRIS 15DEC2022	
DIMENSIONS: mm		CHK: T. BACKENSTOES 15DEC2022	
TOLERANCES UNLESS OTHERWISE SPECIFIED:		APVD: T. BACKENSTOES	NAME: SRC-M OCTACRIMP MACHINE
0 PLC ±		PRODUCT SPEC	SIZE: CAGE CODE: DRAWING NO: RESTRICTED TO:
1 PLC ±		APPLICATION SPEC	SCALE: 2:15 SHEET 1 OF 1 REV C
2 PLC ±		WEIGHT	
3 PLC ±		CUSTOMER DRAWING	
4 PLC ±			
ANGLES ±			
FINISH ±			