

THIS DRAWING IS UNPUBLISHED. RELEASED FOR PUBLICATION 20
 © COPYRIGHT 20 BY - ALL RIGHTS RESERVED.

REVISIONS				
P	LTR	DESCRIPTION	DATE	APVD
1		INITIAL RELEASE	15FEB2018	MS MP
2		WAS 2X 0.4 NOW 2X 0.5	15JUN2018	MS MP

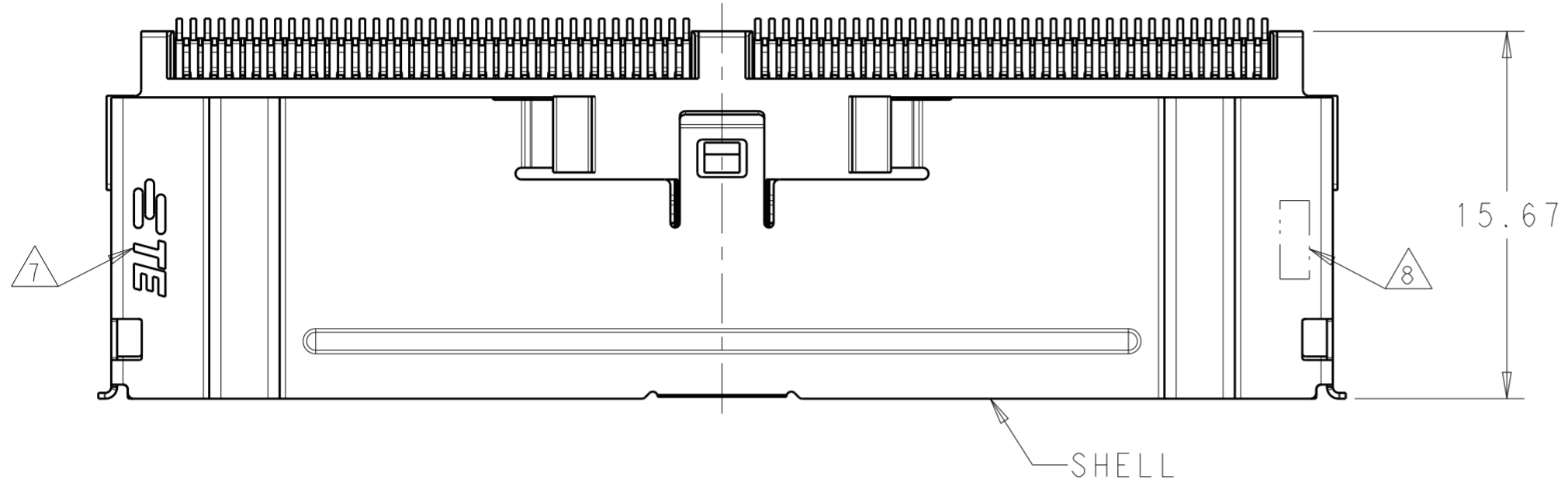

- △1 HOUSING, ORGANIZER AND CONTACT OVERMOLD: LCP, BLACK.
CONTACTS: COPPER ALLOY.
SHELL: COPPER ALLOY, NICKEL PLATED. TIN PLATED ON HOLD DOWNS.
- △2 GOLD PLATED ON MATING INTERFACE. TIN PLATED ON SOLDER TAILS.
- △3 DATUM AND BASIC DIMENSION ESTABLISHED BY CUSTOMER.
- 4. MINIMUM PC BOARD THICKNESS:
SINGLE SIDED = 1.42 MIN.
DOUBLE SIDED = 2 MIN.
- △5 RECOMMENDED COMPONENT KEEP OUT AREA.
- △6 RECOMMENDED COMPONENT AND TRACES KEEP OUT AREA.
- △7 TE CONNECTIVITY LOGO MARKED IN APPROXIMATE AREA SHOWN.
- △8 PART NUMBER AND DATE CODE MARKED IN APPROXIMATE AREA SHOWN.

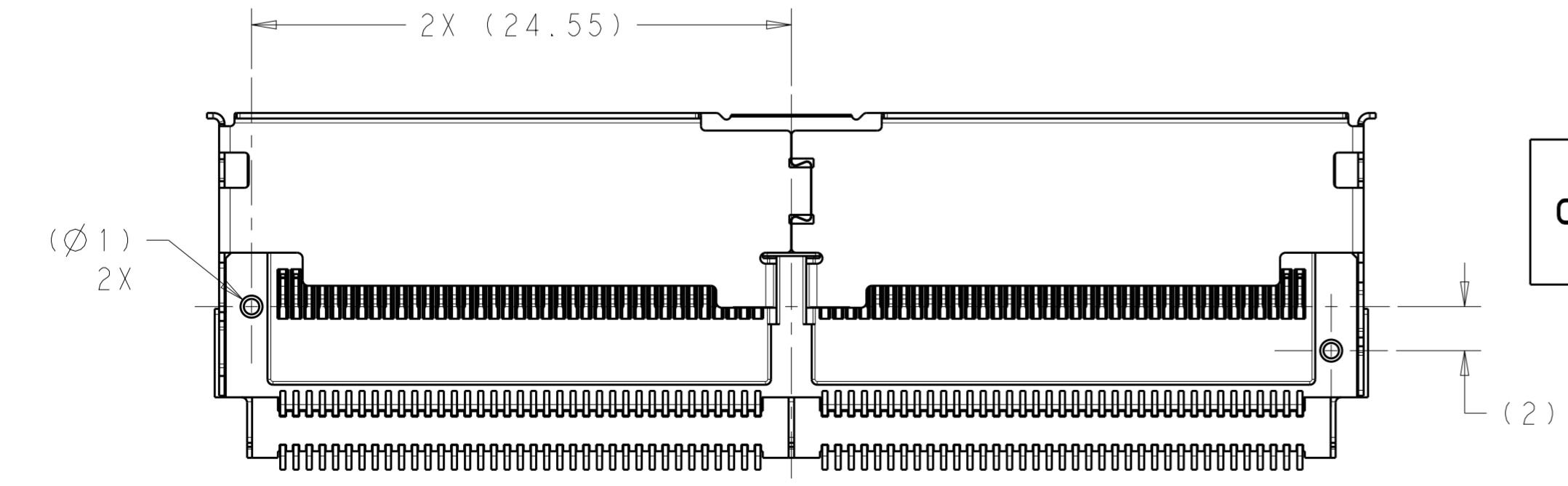
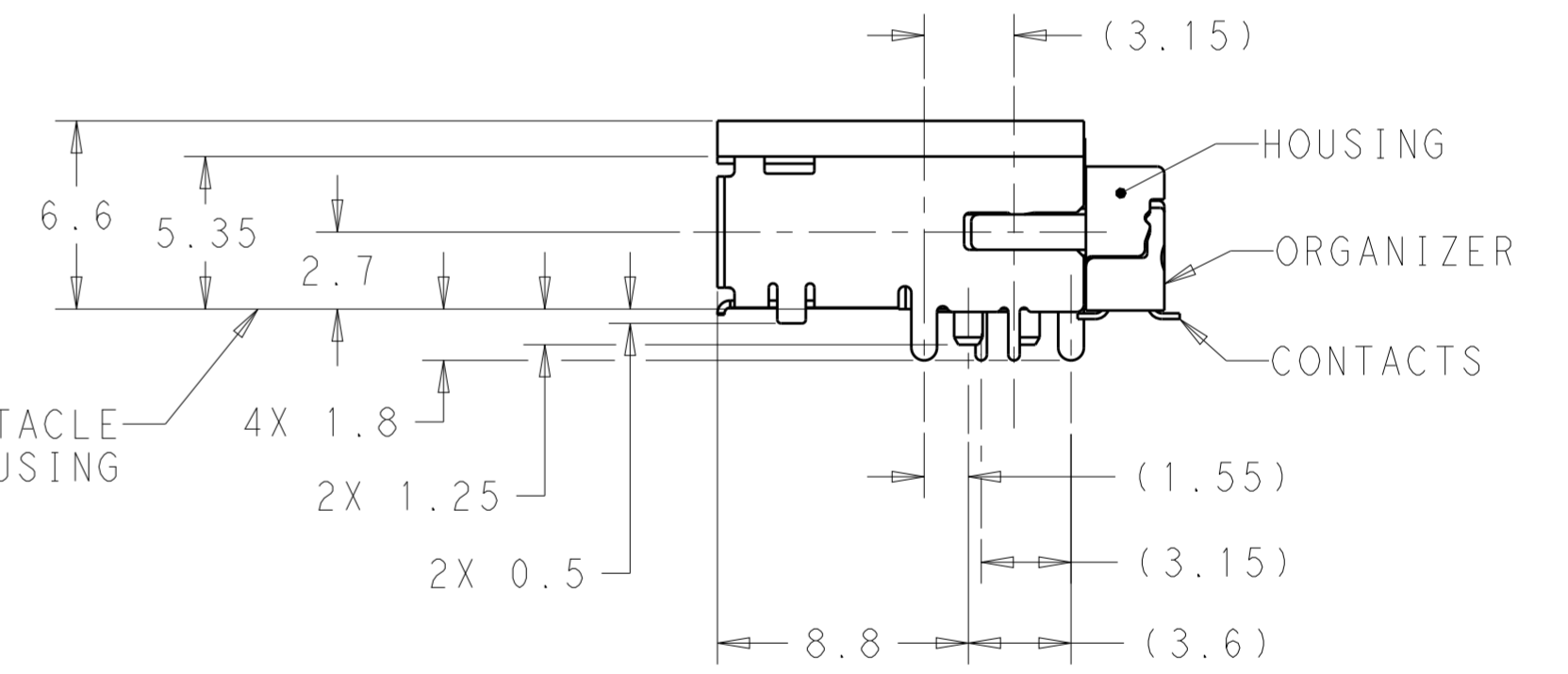
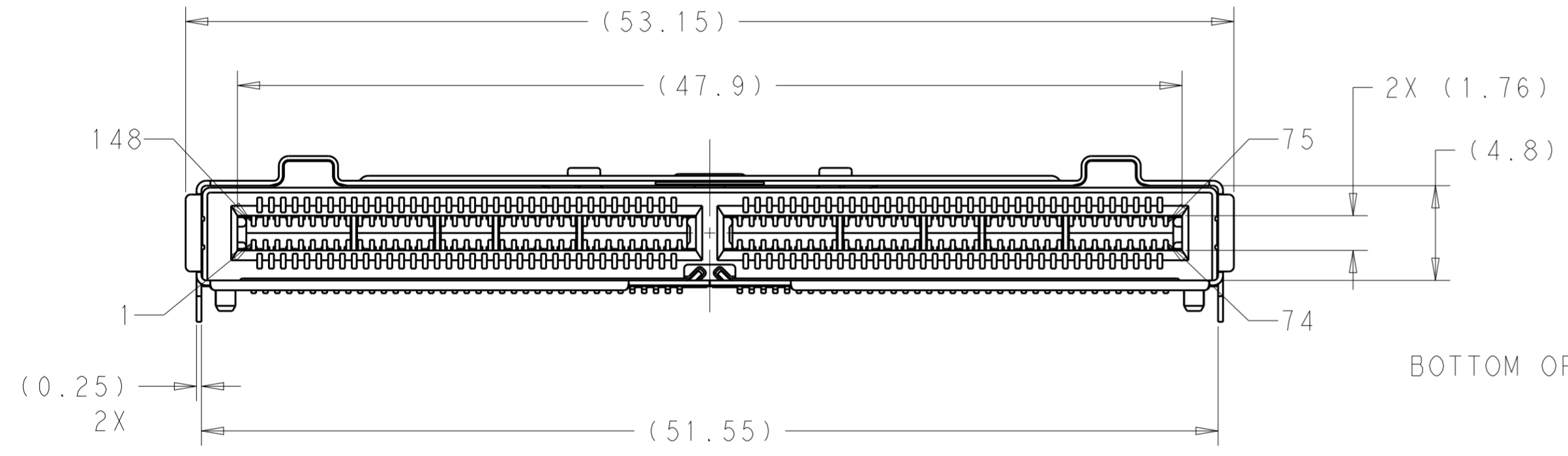

THIS PRODUCT HAS NOT COMPLETED VALIDATION AND QUALIFICATION TESTING

PRELIMINARY NOT RELEASED FOR PRODUCTION

2331498-1
PART NUMBER

THIS DRAWING IS A CONTROLLED DOCUMENT.		DWN M. SHIRK 15FEB2018	TE Connectivity	
		CHK M. PHILLIPS 15FEB2018		
DIMENSIONS: mm		APVD -	NAME RECEPTACLE CONNECTOR, WITH RAILS, RIGHT ANGLE, 148 POSITION, SLIVER	
TOLERANCES UNLESS OTHERWISE SPECIFIED:		PRODUCT SPEC -	SIZE A2	
0 PLC ±0.15		APPLICATION SPEC -	CAGE CODE -	
1 PLC ±0.15		WEIGHT -	DRAWING NO. C-2331498	
2 PLC ±0.15		CUSTOMER DRAWING	RESTRICTED TO	
3 PLC ±		SCALE 4:1	SHEET 1 OF 3	
4 PLC ±			REV 2	
ANGLES ±				
FINISH				

THIS DRAWING IS UNPUBLISHED. RELEASED FOR PUBLICATION 20
 © COPYRIGHT 20 BY - ALL RIGHTS RESERVED.

REVISIONS				
P	LTR	DESCRIPTION	DATE	APVD
-	-	SEE SHEET 1	-	-

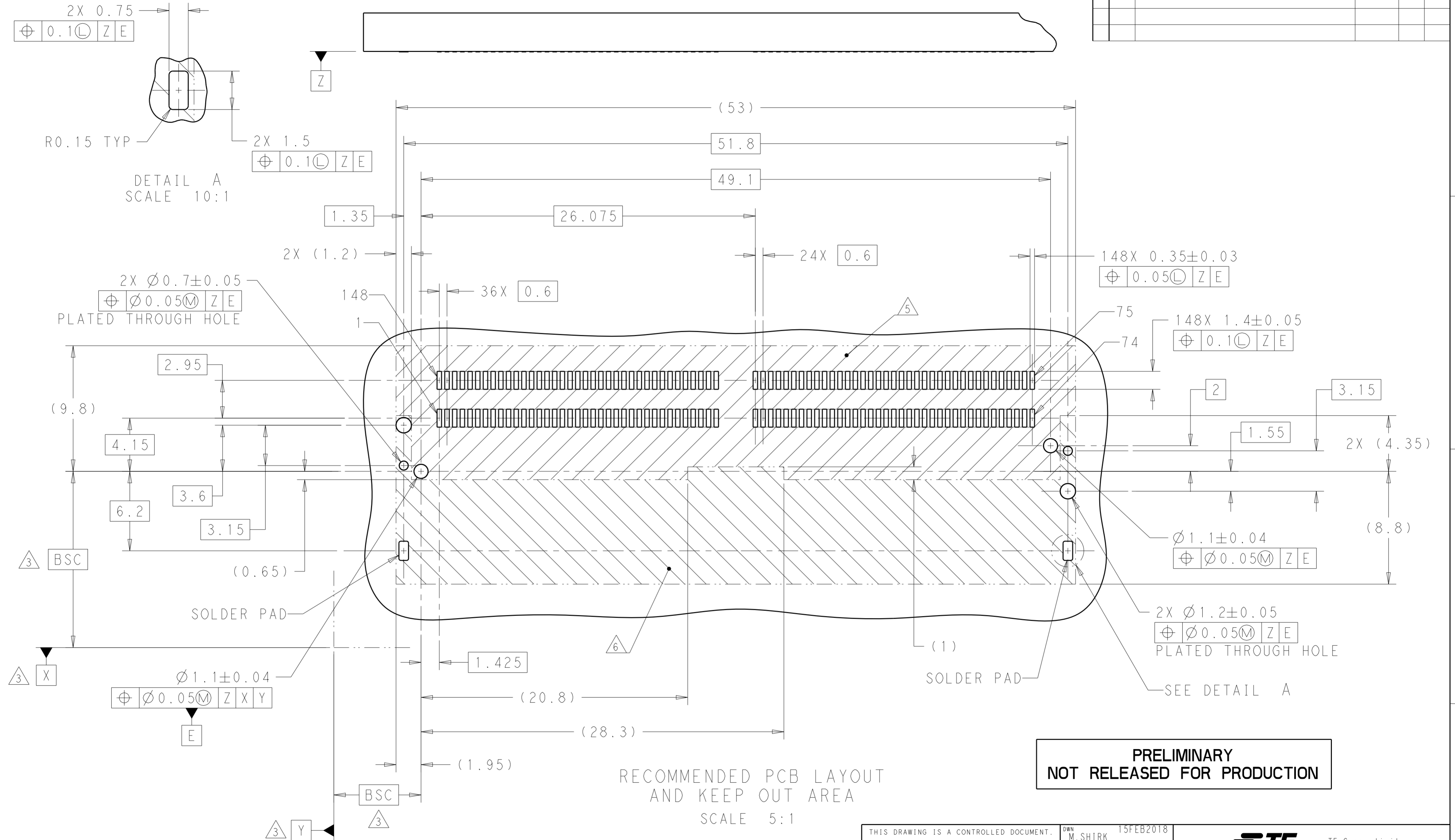

**PRELIMINARY
 NOT RELEASED FOR PRODUCTION**

**THIS PRODUCT HAS NOT
 COMPLETED VALIDATION AND
 QUALIFICATION TESTING**

THIS DRAWING IS A CONTROLLED DOCUMENT.		DWN M. SHIRK 15FEB2018	TE Connectivity	
		CHK M. PHILLIPS 15FEB2018		
DIMENSIONS: mm		APVD -	NAME RECEPTACLE CONNECTOR, WITH RAILS, RIGHT ANGLE, 148 POSITION, SLIVER	
TOLERANCES UNLESS OTHERWISE SPECIFIED:		PRODUCT SPEC -	RESTRICTED TO	
0 PLC ± 0.15		APPLICATION SPEC -	SIZE A2	CAGE CODE -
1 PLC ± 0.15		WEIGHT -	DRAWING NO. C-2331498	SCALE 4:1
2 PLC ± 0.15		CUSTOMER DRAWING	SHEET 2 OF 3	REV 2
3 PLC \pm				
4 PLC \pm				
ANGLES \pm				
FINISH \pm				

THIS DRAWING IS UNPUBLISHED. RELEASED FOR PUBLICATION 20
 © COPYRIGHT 20 BY - ALL RIGHTS RESERVED.

REVISIONS				
P	LTR	DESCRIPTION	DATE	APVD
-		SEE SHEET 1	-	-

PIN #	DESCRIPTION	PIN #	DESCRIPTION
1	SIGNAL GROUND	148	SIGNAL GROUND
2	SIGNAL	147	SIGNAL
3	SIGNAL	146	SIGNAL
4	SIGNAL GROUND	145	SIGNAL GROUND
5	SIGNAL	144	SIGNAL
6	SIGNAL	143	SIGNAL
7	SIGNAL GROUND	142	SIGNAL GROUND
8	SIGNAL	141	SIGNAL
9	SIGNAL	140	SIGNAL
10	SIGNAL GROUND	139	SIGNAL GROUND
11	SIGNAL	138	SIGNAL
12	SIGNAL	137	SIGNAL
13	SIGNAL GROUND	136	SIGNAL GROUND
14	SIGNAL	135	SIGNAL
15	SIGNAL	134	SIGNAL
16	SIGNAL GROUND	133	SIGNAL GROUND
17	SIGNAL	132	SIGNAL
18	SIGNAL	131	SIGNAL
19	SIGNAL GROUND	130	SIGNAL GROUND
20	SIGNAL	129	SIGNAL
21	SIGNAL	128	SIGNAL
22	SIGNAL GROUND	127	SIGNAL GROUND
23	SIGNAL	126	SIGNAL
24	SIGNAL	125	SIGNAL
25	SIGNAL GROUND	124	SIGNAL GROUND
26	SIGNAL	123	SIGNAL
27	SIGNAL	122	SIGNAL
28	SIGNAL GROUND	121	SIGNAL GROUND
29	SIGNAL	120	SIGNAL
30	SIGNAL	119	SIGNAL
31	SIGNAL GROUND	118	SIGNAL GROUND
32	SIGNAL	117	SIGNAL
33	SIGNAL	116	SIGNAL
34	SIGNAL GROUND	115	SIGNAL GROUND
35	SIGNAL	114	SIGNAL
36	SIGNAL	113	SIGNAL
37	SIGNAL GROUND	112	SIGNAL GROUND

PIN #	DESCRIPTION	PIN #	DESCRIPTION
38	SIGNAL GROUND	111	SIGNAL GROUND
39	SIGNAL	110	SIGNAL
40	SIGNAL	109	SIGNAL
41	SIGNAL GROUND	108	SIGNAL GROUND
42	SIGNAL	107	SIGNAL
43	SIGNAL	106	SIGNAL
44	SIGNAL GROUND	105	SIGNAL GROUND
45	SIGNAL	104	SIGNAL
46	SIGNAL	103	SIGNAL
47	SIGNAL GROUND	102	SIGNAL GROUND
48	SIGNAL	101	SIGNAL
49	SIGNAL	100	SIGNAL
50	SIGNAL GROUND	99	SIGNAL GROUND
51	SIGNAL	98	SIGNAL
52	SIGNAL	97	SIGNAL
53	SIGNAL GROUND	96	SIGNAL GROUND
54	SIGNAL	95	SIGNAL
55	SIGNAL	94	SIGNAL
56	SIGNAL GROUND	93	SIGNAL GROUND
57	SIGNAL	92	SIGNAL
58	SIGNAL	91	SIGNAL
59	SIGNAL GROUND	90	SIGNAL GROUND
60	SIGNAL	89	SIGNAL
61	SIGNAL	88	SIGNAL
62	SIGNAL GROUND	87	SIGNAL GROUND
63	SIGNAL	86	SIGNAL
64	SIGNAL	85	SIGNAL
65	SIGNAL GROUND	84	SIGNAL GROUND
66	SIGNAL	83	SIGNAL
67	SIGNAL	82	SIGNAL
68	SIGNAL GROUND	81	SIGNAL GROUND
69	SIGNAL	80	SIGNAL
70	SIGNAL	79	SIGNAL
71	SIGNAL GROUND	78	SIGNAL GROUND
72	SIGNAL	77	SIGNAL
73	SIGNAL	76	SIGNAL
74	SIGNAL GROUND	75	SIGNAL GROUND

**PRELIMINARY
NOT RELEASED FOR PRODUCTION**

**THIS PRODUCT HAS NOT
COMPLETED VALIDATION AND
QUALIFICATION TESTING**

THIS DRAWING IS A CONTROLLED DOCUMENT.		DWN M. SHIRK 15FEB2018	 TE Connectivity
DIMENSIONS: mm		CHK M. PHILLIPS 15FEB2018	
TOLERANCES UNLESS OTHERWISE SPECIFIED: 0 PLC ±0.15 1 PLC ±0.15 2 PLC ±0.15 3 PLC ± 4 PLC ± ANGLES ± FINISH		APVD -	NAME RECEPTACLE CONNECTOR, WITH RAILS, RIGHT ANGLE, 148 POSITION, SLIVER
MATERIAL -		PRODUCT SPEC -	SIZE A2
		APPLICATION SPEC -	CAGE CODE -
		WEIGHT -	DRAWING NO C-2331498
		CUSTOMER DRAWING	RESTRICTED TO
		SCALE 4:1	SHEET 3 OF 3
			REV 2