

THIS DRAWING IS UNPUBLISHED. RELEASED FOR PUBLICATION
 © COPYRIGHT - TE Connectivity Ltd. ALL RIGHTS RESERVED.

REVISIONS				
P	LTR	DESCRIPTION	DATE	APVD
A		ECR-18-012767	16AUG2018	RSM AS

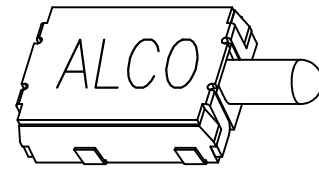

SCHEMATIC (1P1T)

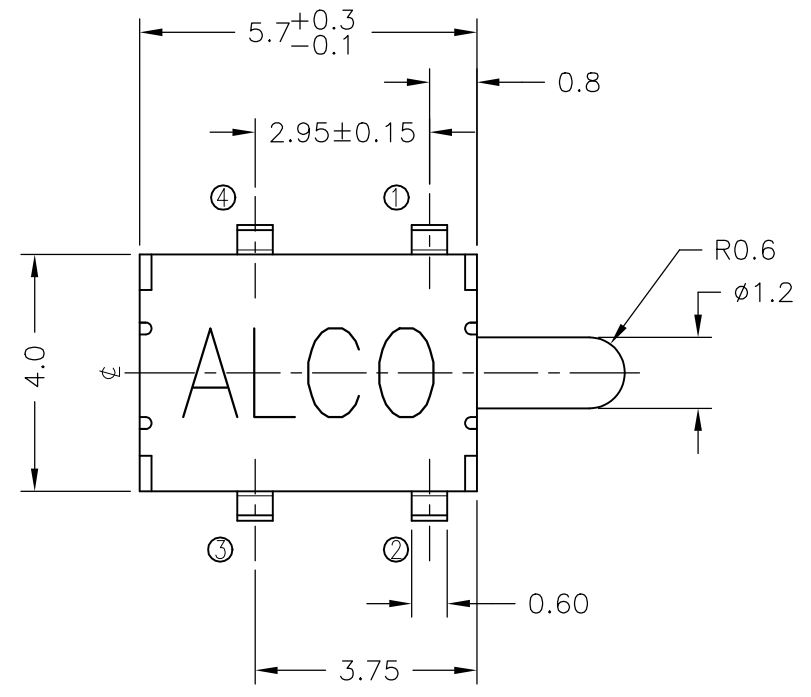
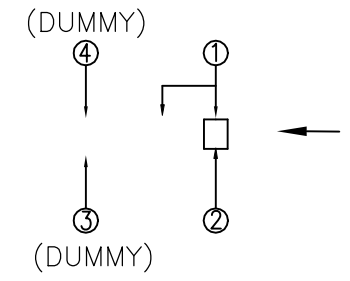

P.C.B. LAYOUT

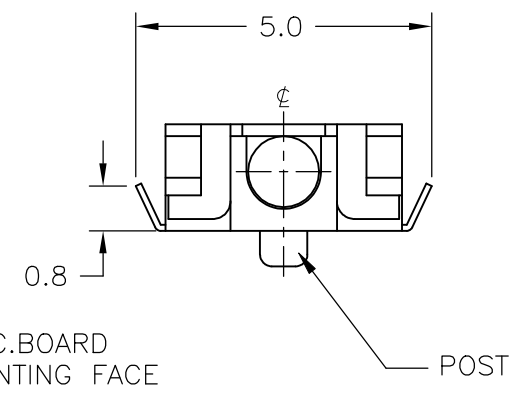
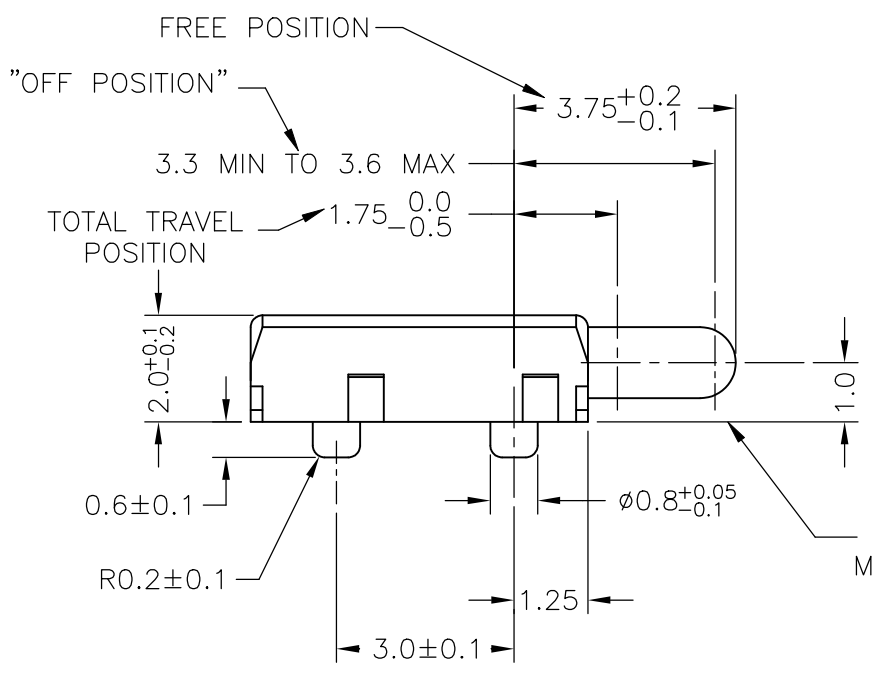
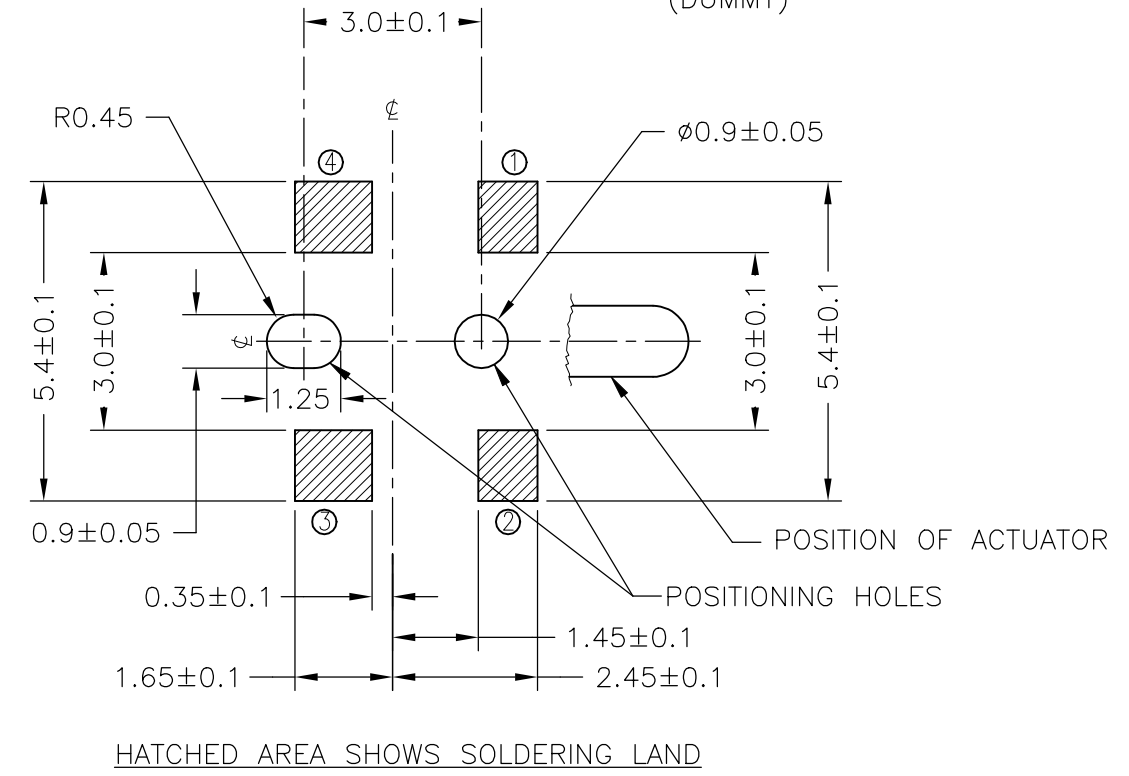

JJGHOUJ200NCHPMRTR	2331403-1
SMART PART NUMBER	PART NUMBER

THIS DRAWING IS A CONTROLLED DOCUMENT.		DWN 30APR2018 RAVI.S	TE Connectivity Ltd.		
DIMENSIONS: mm		CHK 30APR2018 ALEXANDER SHARPE			
TOLERANCES UNLESS OTHERWISE SPECIFIED:		APVD 30APR2018 ALEXANDER SHARPE	NAME DETECTOR SWITCH, JG SERIES, 5.7X4.0mm, HORIZONTAL, SMT, POSTS		
0 PLC ± - 1 PLC ± 0.3 2 PLC ± - 3 PLC ± - 4 PLC ± - ANGLES ± -		PRODUCT SPEC -			
MATERIAL -		FINISH -	APPLICATION SPEC -	SIZE CAGE CODE DRAWING NO RESTRICTED TO A3 00779 C-2331403 -	
CUSTOMER DRAWING			WEIGHT -	SCALE 8:1	SHEET 1 of 4
				REV A	

4

3

2

1

THIS DRAWING IS UNPUBLISHED.

RELEASED FOR PUBLICATION

REVISIONS

© COPYRIGHT - TE Connectivity Ltd.

ALL RIGHTS RESERVED.

P	LTR	DESCRIPTION	DATE	DWN	APVD
-	-	SEE SHEET 1	-	-	-

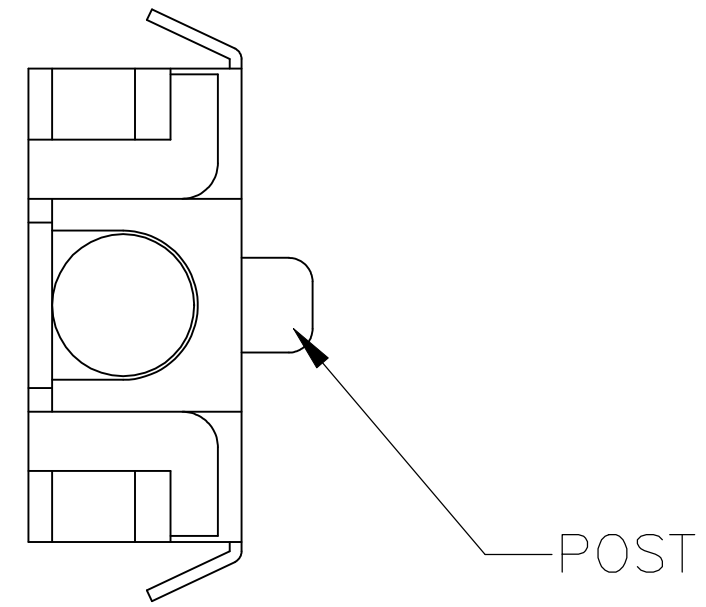
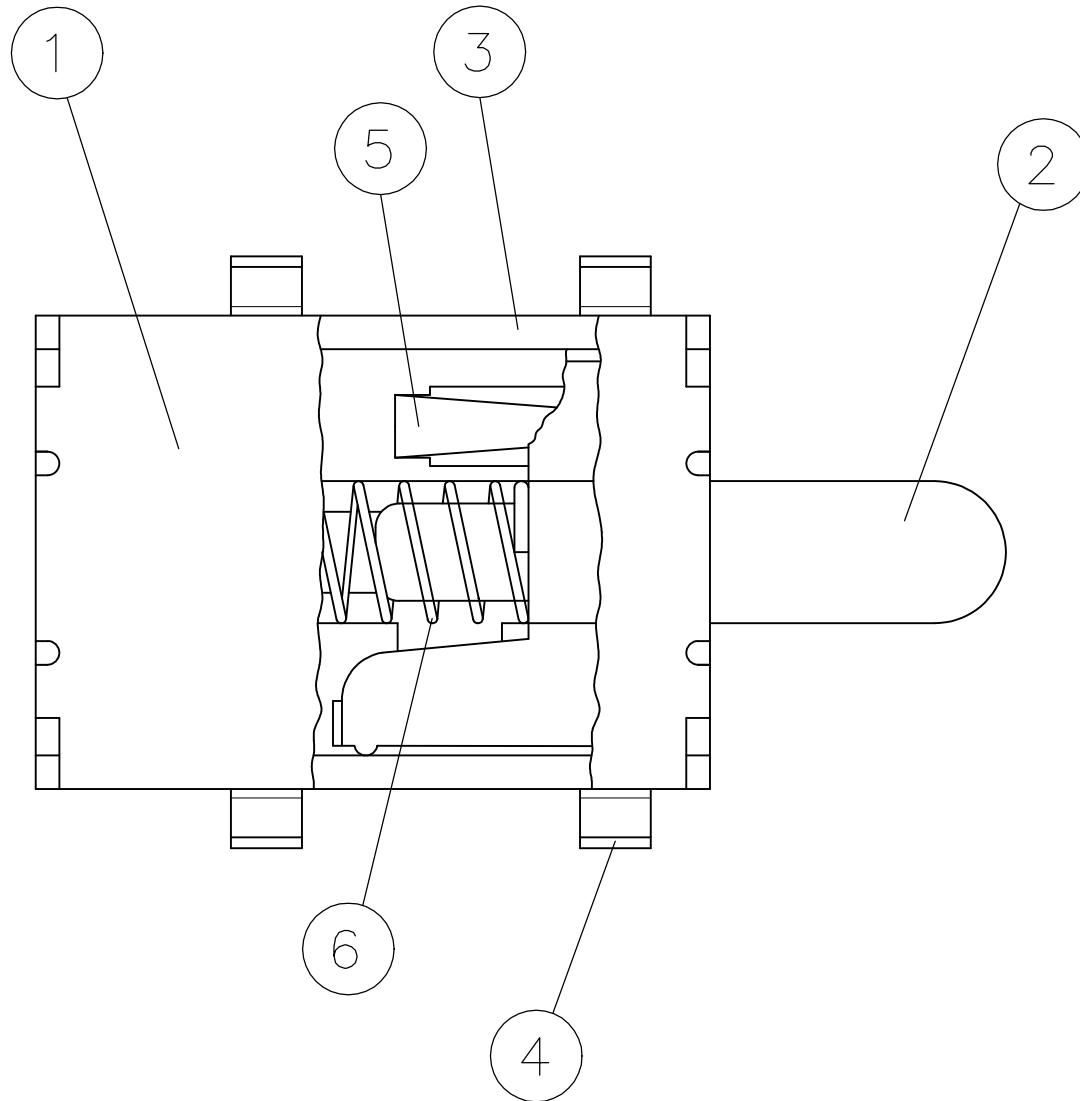

-	STAINLESS STEEL	COIL SPRING	6
SILVER PLATE	COPPER ALLOY	CONTACT PLATE	5
SILVER PLATE OVER NICKEL PLATE	COPPER ALLOY	TERMINAL	4
WHITE	THERMOPLASTIC	FRAME	3
BLACK	THERMOPLASTIC	ACTUATOR	2
-	STAINLESS STEEL	COVER	1
COLOR OR FINISH	MATERIAL	PART NAME	NO.

THIS DRAWING IS A CONTROLLED DOCUMENT.		DWN RAVI.S 30APR2018	TE Connectivity Ltd.	
DIMENSIONS: mm		CHK ALEXANDER SHARPE 30APR2018		
		APVD ALEXANDER SHARPE 30APR2018	NAME DETECTOR SWITCH, JIG SERIES, 5.7X4.0mm, HORIZONTAL, SMT, POSTS	
TOLERANCES UNLESS OTHERWISE SPECIFIED:		PRODUCT SPEC -	RESTRICTED TO -	
MATERIAL -		FINISH -	APPLICATION SPEC -	WEIGHT -
0 PLC ± - 1 PLC ± 0.3 2 PLC ± - 3 PLC ± - 4 PLC ± - ANGLES ± -		SCALE 16:1	SHEET 2 of 4	REV A
CUSTOMER DRAWING		SIZE A3	CAGE CODE 00779	DRAWING NO C-2331403

THIS DRAWING IS UNPUBLISHED.

RELEASED FOR PUBLICATION

REVISIONS

© COPYRIGHT - TE Connectivity Ltd.

ALL RIGHTS RESERVED.

P	LTR	DESCRIPTION	DATE	DWN	APVD
-	-	SEE SHEET 1	-	-	-

PACKAGING:

1. STRUCTURE AND MATERIALS

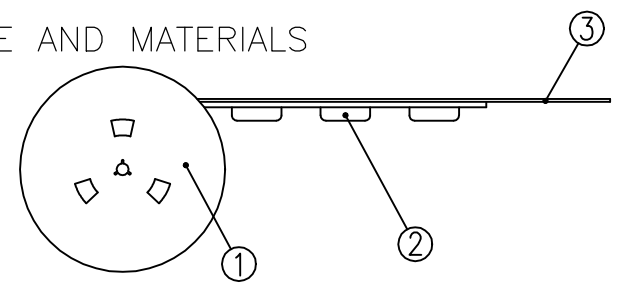

2. PACKAGING QUANTITY : 3,000 SWITCHES/REEL

3. MORE THAN 10 EMPTY POCKETS AT BOTH ENDS OF THE CARRIER TAPE FOR EACH REEL.

4. DIMENSIONS :

TAPE AND REEL PER EIA-481

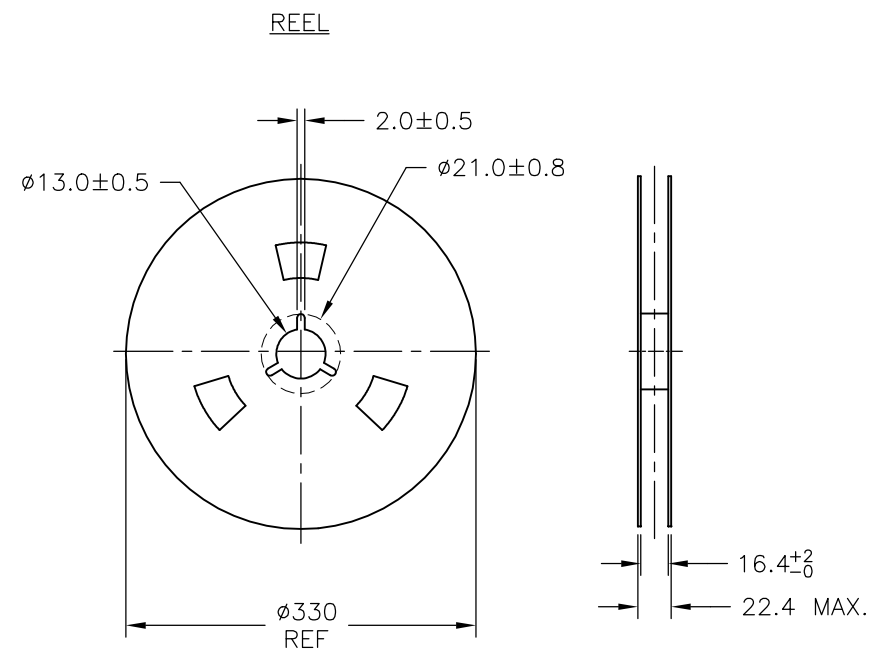
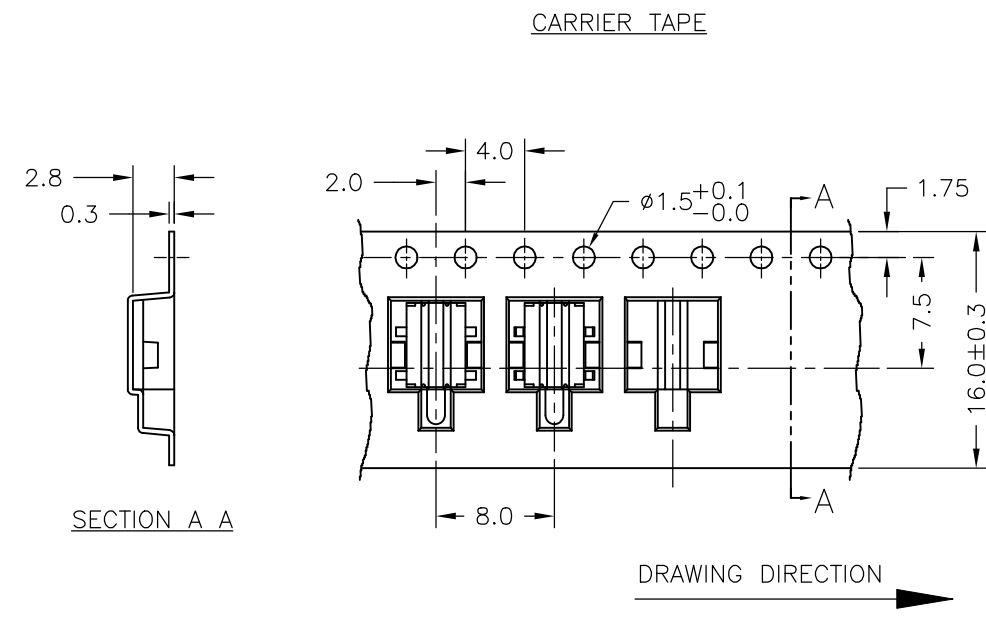

SECTION A A

CARRIER TAPE

REEL

COVER TAPE

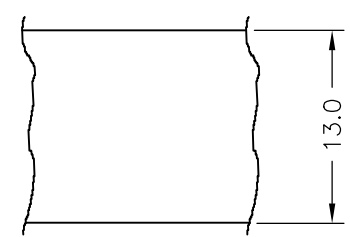

MATERIALS	PARTS NAME	NO.
POLYESTER	COVER TAPE	③
POLYSTYRENE	CARRIER TAPE	②
POLYSTYRENE	REEL	①

THIS DRAWING IS A CONTROLLED DOCUMENT.		DWN	30APR2018	TE Connectivity Ltd.	
		CHK	30APR2018		
		APVD	30APR2018		
		PRODUCT SPEC	ALEXANDER SHARPE		
DIMENSIONS: mm 		TOLERANCES UNLESS OTHERWISE SPECIFIED: 0 PLC ± - 1 PLC ± 0.3 2 PLC ± - 3 PLC ± - 4 PLC ± - ANGLES ± -		NAME DETECTOR SWITCH, JIG SERIES, 5.7X4.0mm, HORIZONTAL, SMT, POSTS	
MATERIAL		FINISH		SIZE	RESTRICTED TO
-		-		A3	-
		WEIGHT		CAGE CODE	DRAWING NO
		-		00779	C-2331403
CUSTOMER DRAWING				SCALE	SHEET
				2:1	3 of 4
				REV	A

THIS DRAWING IS UNPUBLISHED.

RELEASED FOR PUBLICATION

REVISIONS

© COPYRIGHT - TE Connectivity Ltd.

ALL RIGHTS RESERVED.

P	LTR	DESCRIPTION	DATE	DWN	APVD
-	-	SEE SHEET 1	-	-	-

REFLOW SOLDERING:

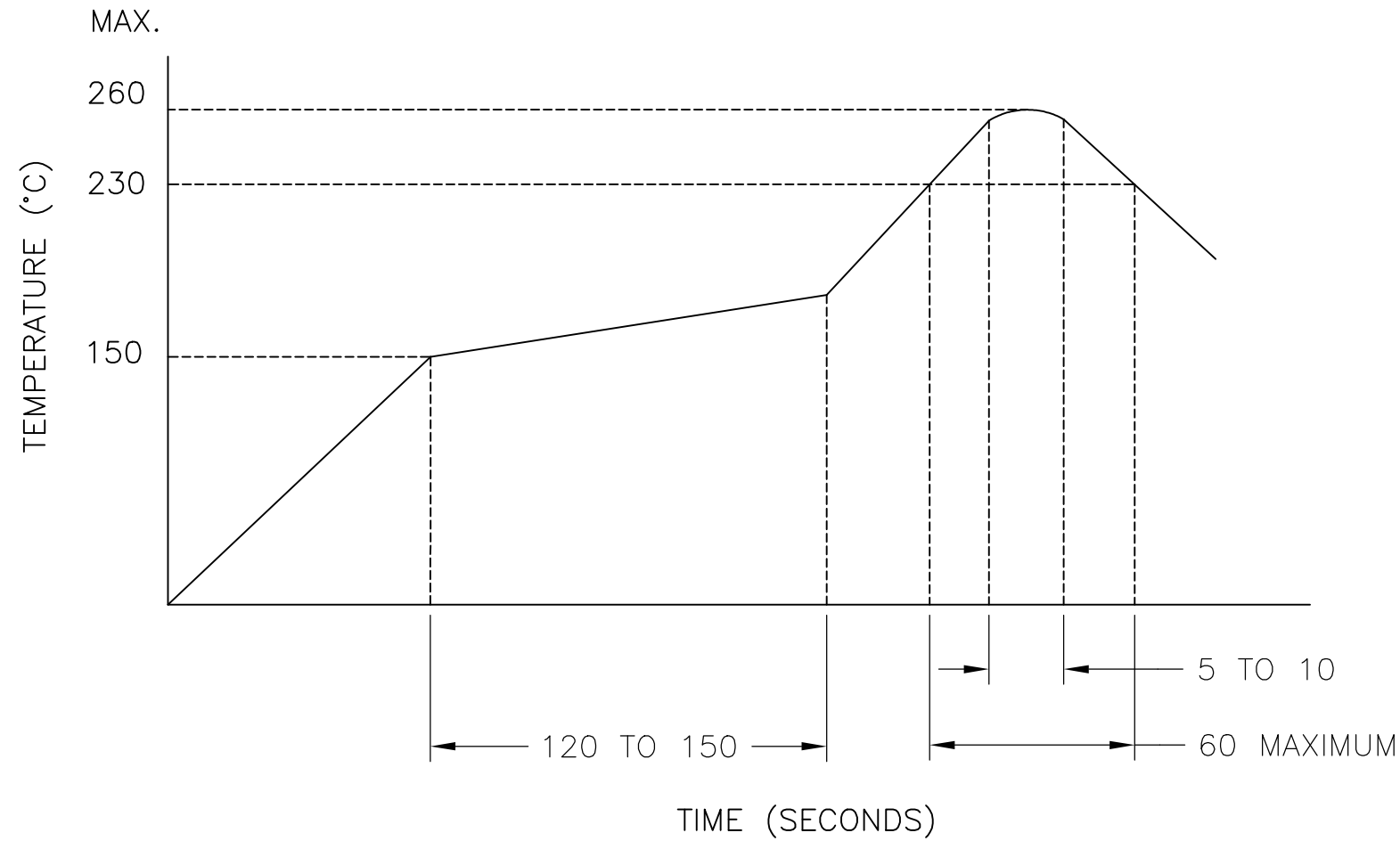

1. RATING: DC 12V, 100mA
2. CONTACT RESISTANCE: 1Ω MAXIMUM (INITIAL)
3. INSULATION RESISTANCE: 100 MΩ MINIMUM
4. WITHSTANDING VOLTAGE: AC 100V, 50 TO 60 Hz, 1 MINUTE
5. OPERATING FORCE: 100+/-50gf
6. LIFE CYCLE: 100,000 CYCLES WITH LOAD
7. OPERATING TEMPERATURE: -10 TO 60°C
8. COMPLIANCE: ALL MATERIALS AND FINISHES SHALL COMPLY WITH EU DIRECTIVE 2002/95/EC OF 27 JAN 2003 (RoHS).

THE TIME-TEMPERATURE CHART IS BASED ON THE TEMPERATURE OF THE MOUNTING SURFACE OF THE P.C.B. FOR THE SWITCH.

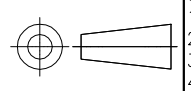
THIS DRAWING IS A CONTROLLED DOCUMENT.		DWN RAVI.S 30APR2018	 TE Connectivity Ltd.	
DIMENSIONS: mm		CHK ALEXANDER SHARPE 30APR2018		
		APVD ALEXANDER SHARPE 30APR2018	NAME DETECTOR SWITCH, JIG SERIES, 5.7X4.0mm, HORIZONTAL, SMT, POSTS	
TOLERANCES UNLESS OTHERWISE SPECIFIED:		PRODUCT SPEC -	RESTRICTED TO -	
MATERIAL -		FINISH -	APPLICATION SPEC -	SIZE A3
		WEIGHT -	CAGE CODE 00779	DRAWING NO C-2331403
		CUSTOMER DRAWING	SCALE 2:1	SHEET 4 of 4
			REV A	