

THIS DRAWING IS UNPUBLISHED.

RELEASED FOR PUBLICATION

REVISIONS

© COPYRIGHT - By -

ALL RIGHTS RESERVED.

P	LTR	DESCRIPTION	DATE	DWN	APVD
	A	INITIAL REL PER LC20-0109-19	23SEP2019	JG	BJ

FIG. 1

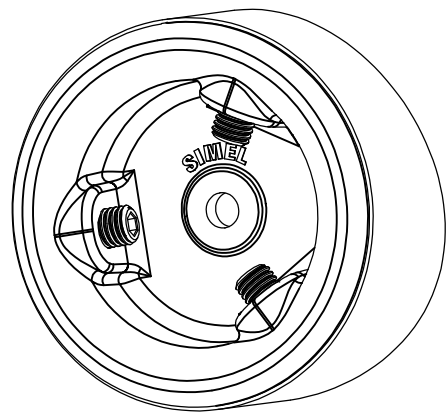

No scale
Sans échelle

Cable 11/16 to 15/16 assembly

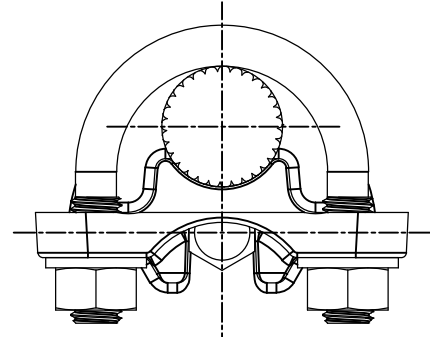
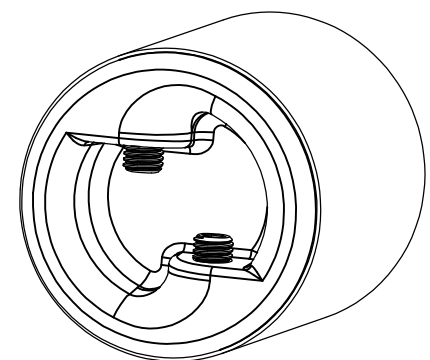
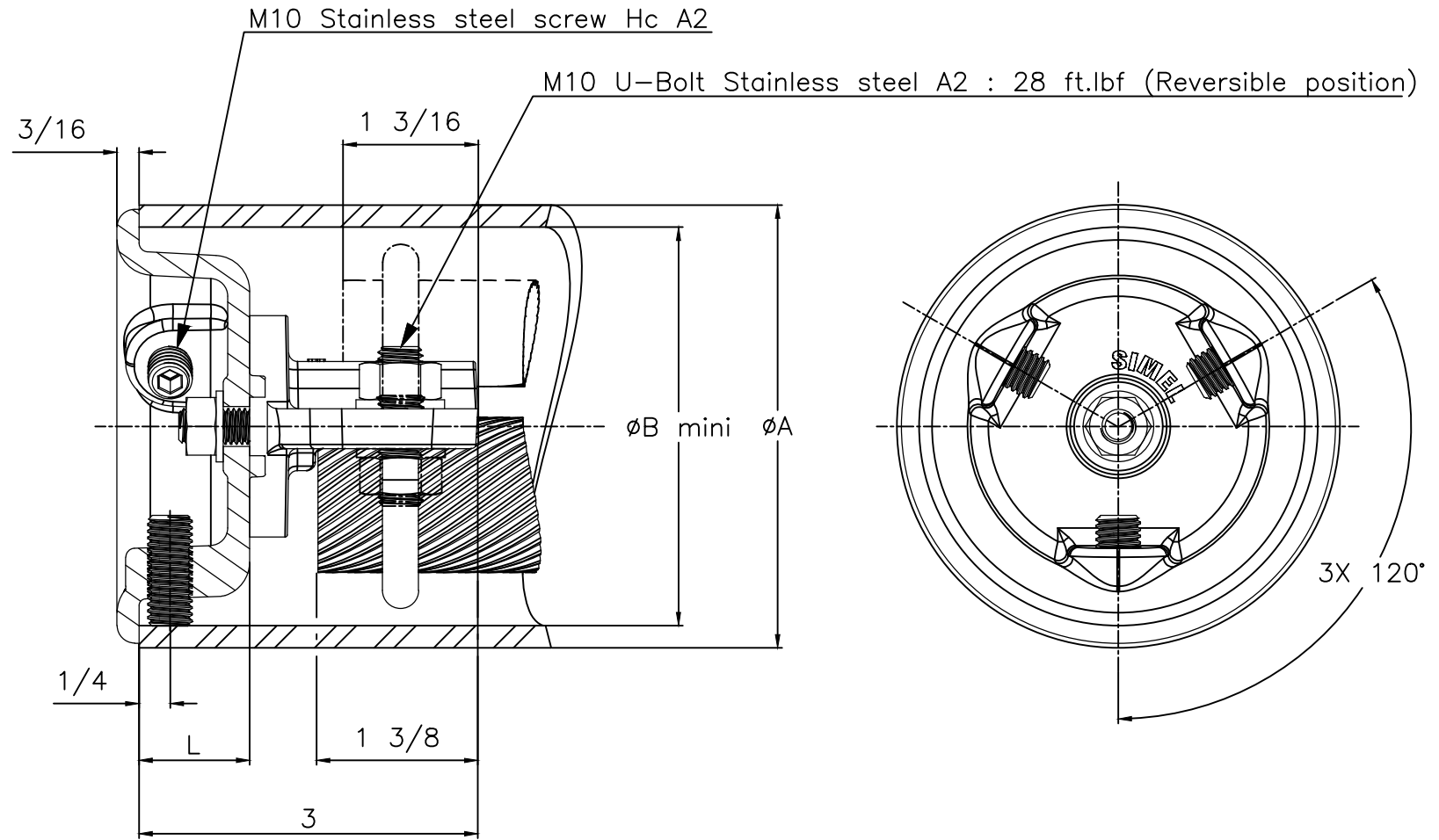
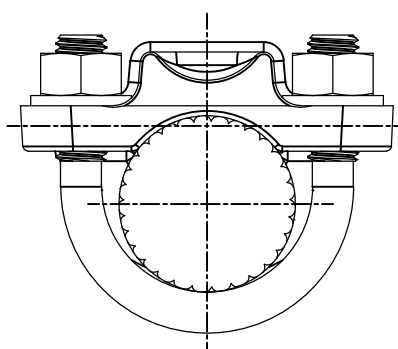

FIG. 2



No scale

Cable 15/16 to 1 11/16 assembly



Cable ø11/16 to 15/16

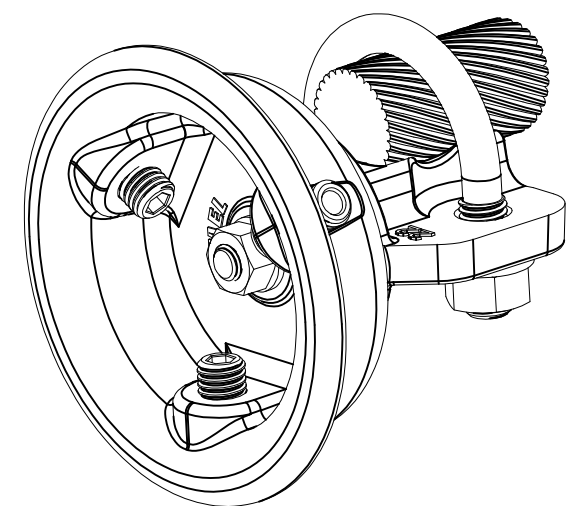

Cable ø15/16 to 1 11/16

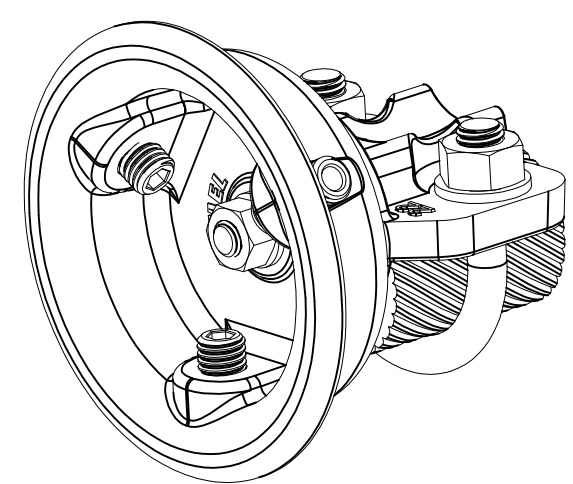

IPS	øA	øB	L	FIG.	DESCRIPTION	PART NUMBER	WEIGHT (Lbs)
3	3-1/2	2-3/4	13/16	2	5 TABPC 82 T3*IPS	2316490-1	0.57
3-1/2	4	3-1/8	1	1	5 TABPC 82 T3*1/2IPS	2316490-2	0.92
4	4-1/2	3-9/16	13/16	1	5 TABPC 82 T4*IPS	2316490-3	1.04
5	5-9/16	4-13/16	13/16	1	5 TABPC 82 T5*IPS	2316490-4	1.19
6	6-5/8	5-9/16	13/16	1	5 TABPC 82 T6*IPS	2316490-5	1.37

THIS DRAWING IS A CONTROLLED DOCUMENT.

DWN GARNIER P. 10-Mar-15

DIMENSIONS: inches

TOLERANCES UNLESS OTHERWISE SPECIFIED:

0 PLC	± -
1 PLC	± -
2 PLC	± -
3 PLC	± -
4 PLC	± -
ANGLES	± -
FINISH	-

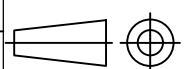

MATERIAL

CHK	-
APVD	-
PRODUCT SPEC	-
APPLICATION SPEC	-
WEIGHT	Lbs



END CAP WITH DAMPING CABLE HOLDER
3 TO 6 IPS CONDUCTOR,
SIMABUS

SIZE	CAGE CODE	DRAWING NO	RESTRICTED TO
A3	00779	C=2316490	-

ITEM:.....

CUSTOMER DRAWING SCALE NTS SHEET 1 OF 1 REV A