

THIS DRAWING IS UNPUBLISHED.

RELEASED FOR PUBLICATION

-. - .

© COPYRIGHT - By -

ALL RIGHTS RESERVED.

REVISIONS

P	LTR	DESCRIPTION	DATE	DWN	APVD
	A	CREATION	20-Fev-17	TC	-

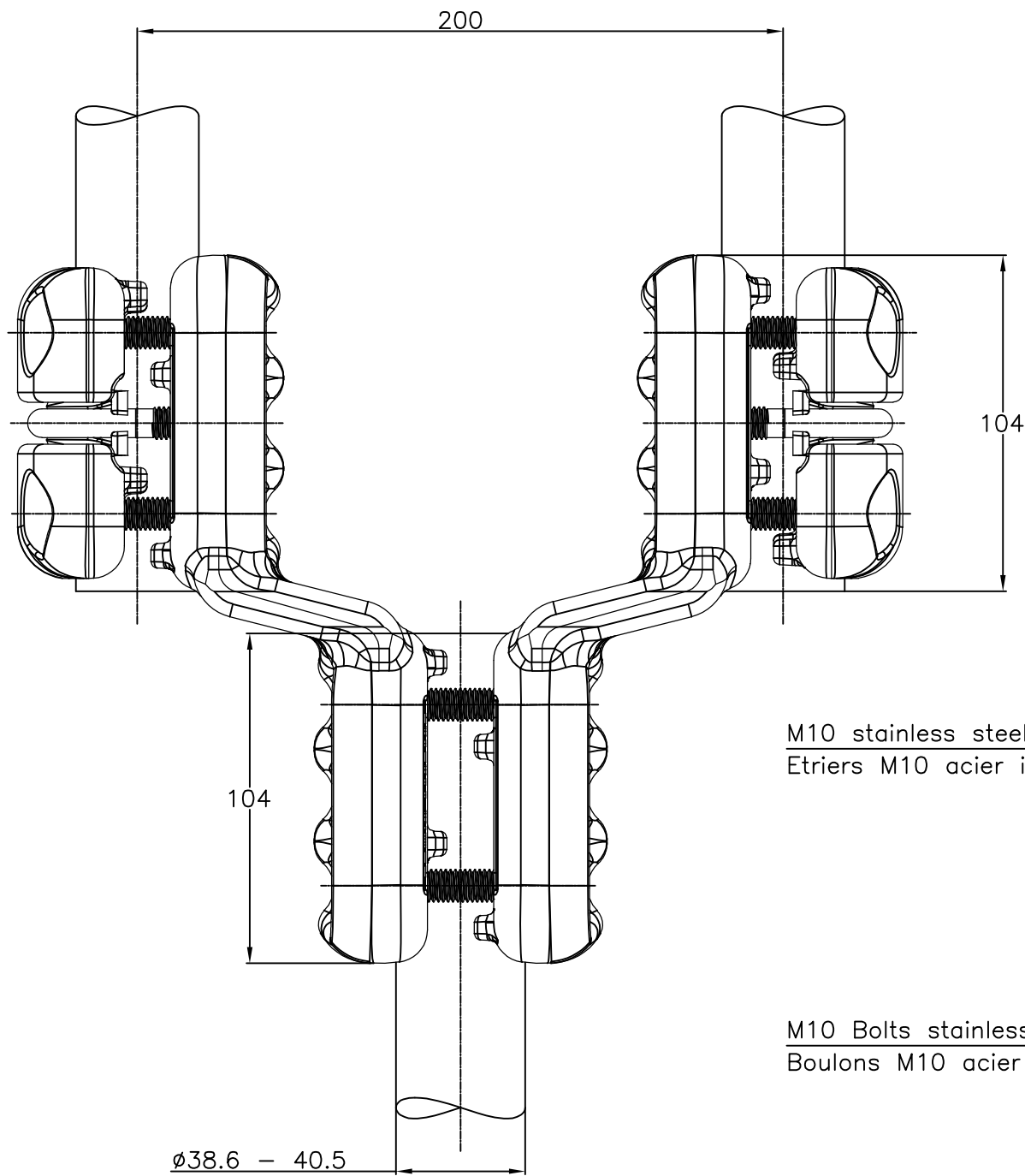

M10 stainless steel U-Bolts A4: 37Nm
 Etriers M10 acier inoxydable A4: 37Nm

M10 Bolts stainless steel A2: 37Nm
 Boulons M10 acier inoxydable A2: 37Nm

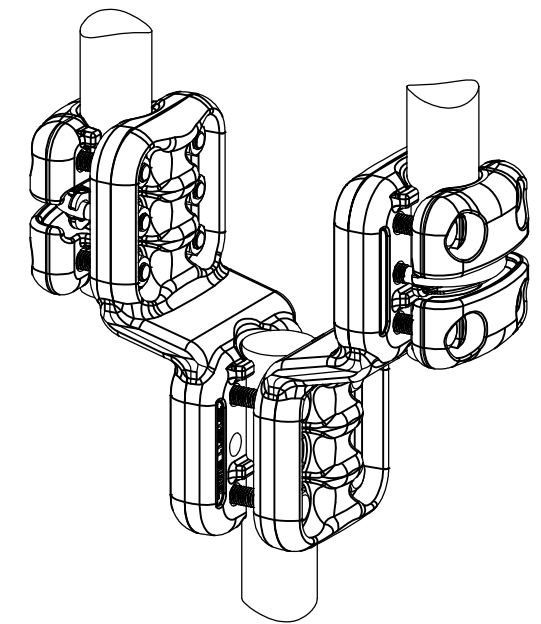

No scale - sans echelle

No scale - sans echelle

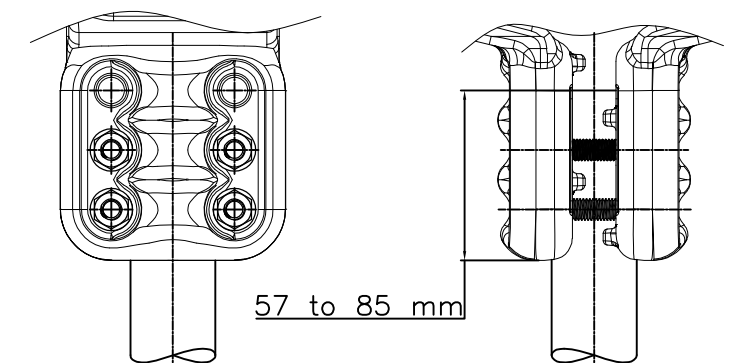

NOTE 1: Bolts Assembly for Stud length 57 to 85mm
 Assemblage Boulons sur Borne longueur 57 à 85mm

ITEM:.....

THIS DRAWING IS A CONTROLLED DOCUMENT.		DWN CHARTON	20-Fev-17	STE TE Connectivity	
DIMENSIONS: mm		CHK -	APVD -		
	TOLERANCES UNLESS OTHERWISE SPECIFIED:	APVD -	PRODUCT SPEC 108-69096-001	5 CJ 82 F MR385 E200 M405	
	0 PLC ± -	APVD -	APPLICATION SPEC -	SIZE A3	CAGE CODE 00779
MATERIAL -	FINISH -	APVD -	APPROX.WEIGHT 3.4 kg	DRAWING NO C=2314499	RESTRICTED TO -
CUSTOMER DRAWING			SCALE 1/2	SHEET 1 OF 1	REV A