

- 1 : AS SHOWN

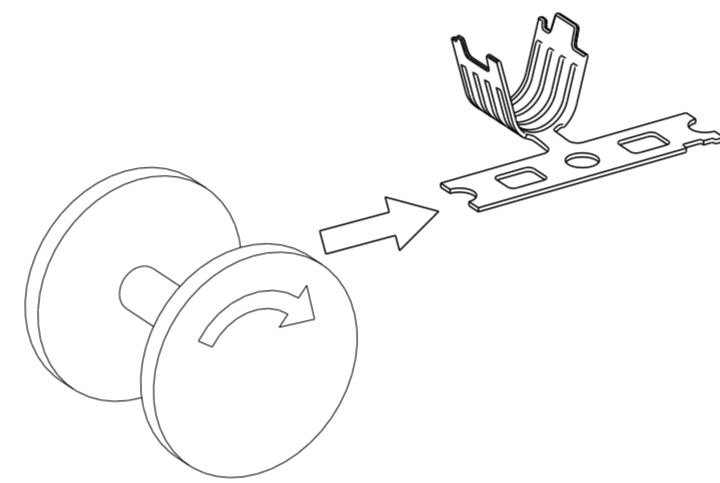
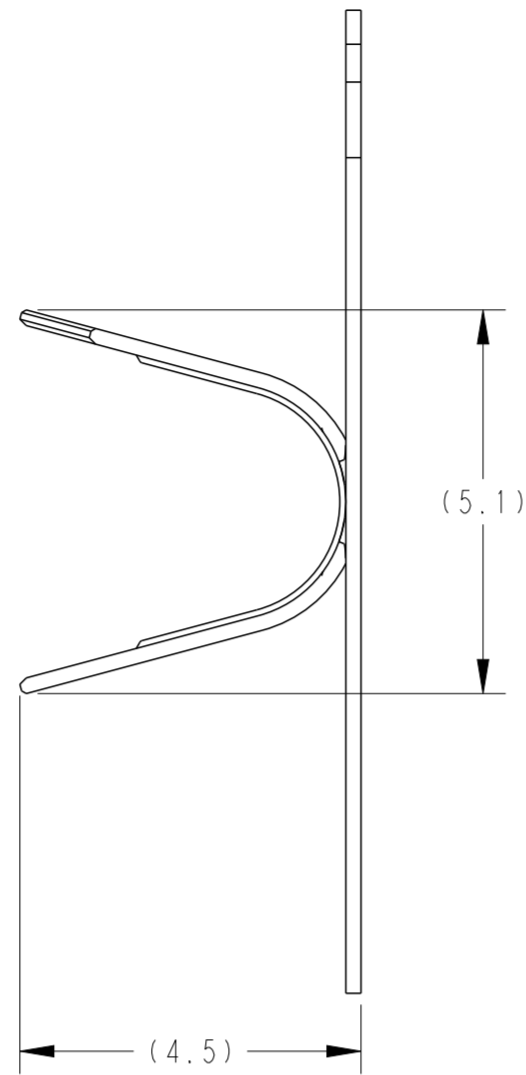
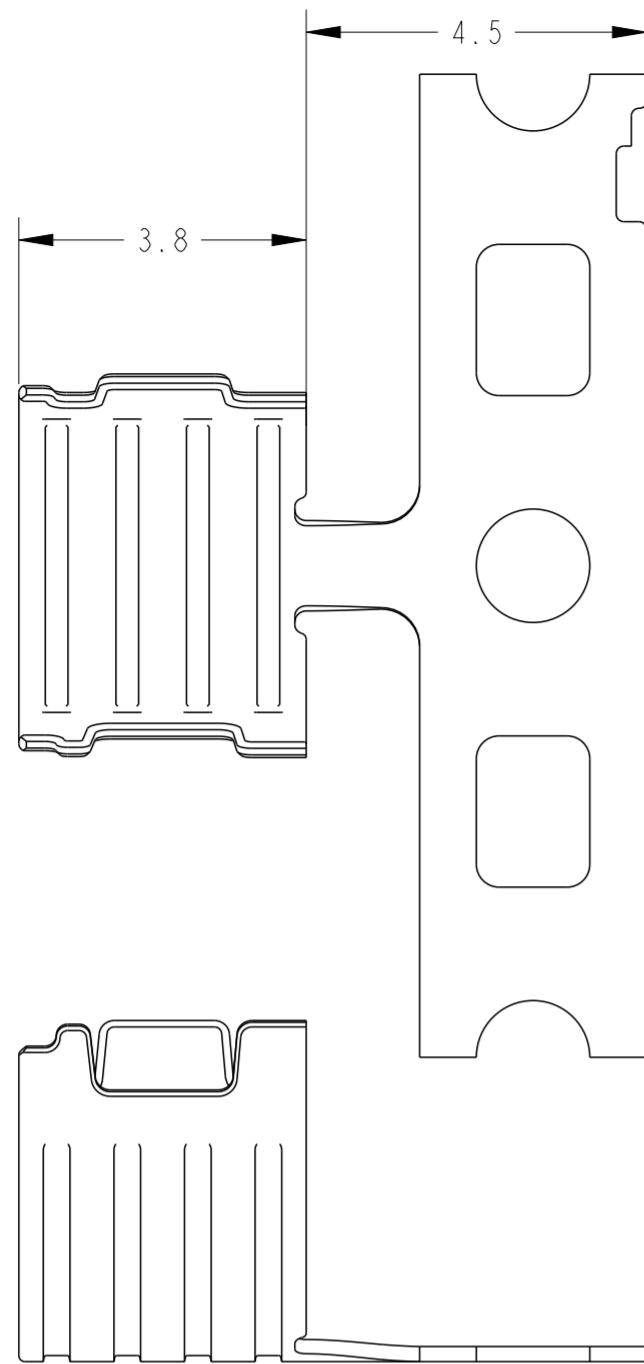

| REVISIONS | | | | |
|-----------|-----|-------------|-----------|-------|
| P | LTR | DESCRIPTION | DATE | APVD |
| | A | RELEASED | 25JUN2020 | YS TK |
| | | | | |
| | | | | |

1. CRIMPING OPERATION AND APPLICATION TOOL PN
SEE SPEC. 114-78018
2. WEIGHT WITHOUT CARRIER STRIP

- 2 : AS SHOWN

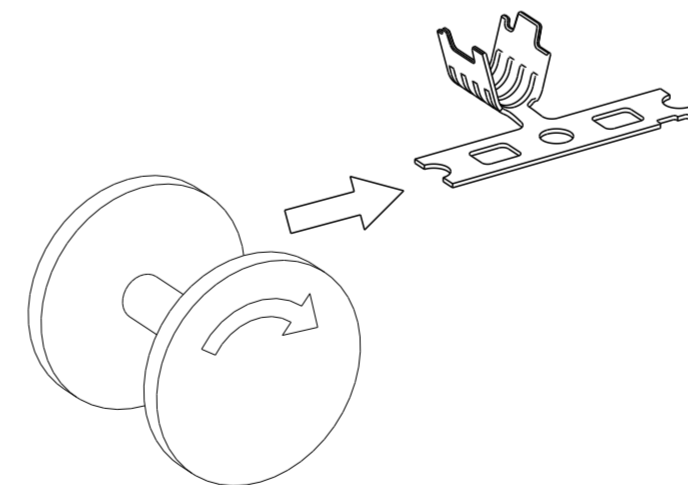
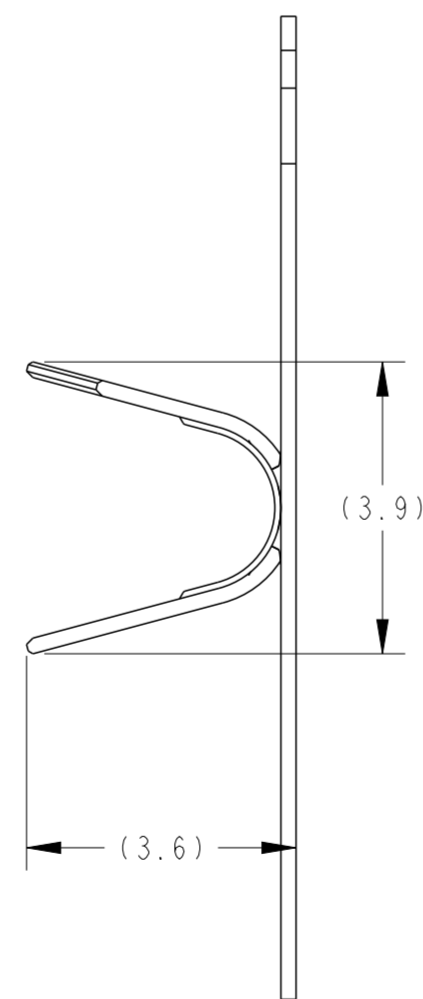
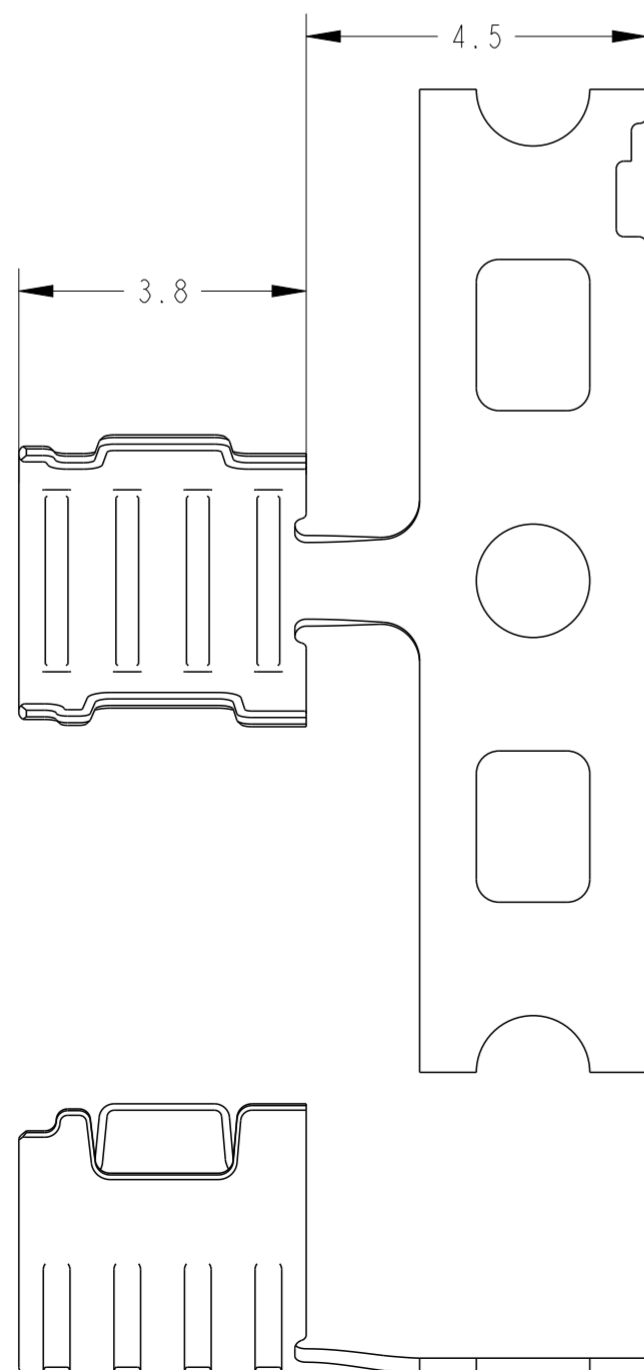

| | | | |
|------------------|----------|-----------------|-----------|
| 1.5D | 0.04 | STAINLESS STEEL | 2312063-2 |
| 2.5D | 0.06 | STAINLESS STEEL | 2312063-1 |
| APPLICABLE CABLE | WEIGHT g | MATERIAL | PART NO |

THIS DRAWING IS A CONTROLLED DOCUMENT.

| | | | |
|-----------------------|---|-------------------------------|---|
| DIMENSIONS: mm | TOLERANCES UNLESS OTHERWISE SPECIFIED: 0-PLC ±0.3 1-PLC ±0.1 2-PLC ±0.01 3-PLC ±0.001 4-PLC ±0.0001 ANGLES ±3° FINISH UNPLATED | DWN Y. SATO 25JUN2020 | TE Connectivity |
| | | CHK T. KUMAMOTO 25JUN2020 | |
| | MATERIAL SEE TABLE | APVD T. KIMURA 25JUN2020 | PRODUCT SPEC 108-140140 |
| | | APPLICATION SPEC 114-78018 | RESTRICTED TO - |
| MATERIAL SEE TABLE | | WEIGHT SEE TABLE | SIZE A2 CAGE CODE 00779 DRAWING NO. C-2312063 SCALE 5:1 SHEET 1 OF 1 REV A |

CUSTOMER DRAWING