

LOC		DIST		REVISIONS			
REV	DATE	DESCRIPTION	DATE	BY	APPV		
J1	26MAY2006	REVISED PER ECO-06-011451	26MAY2006	KS	JL		

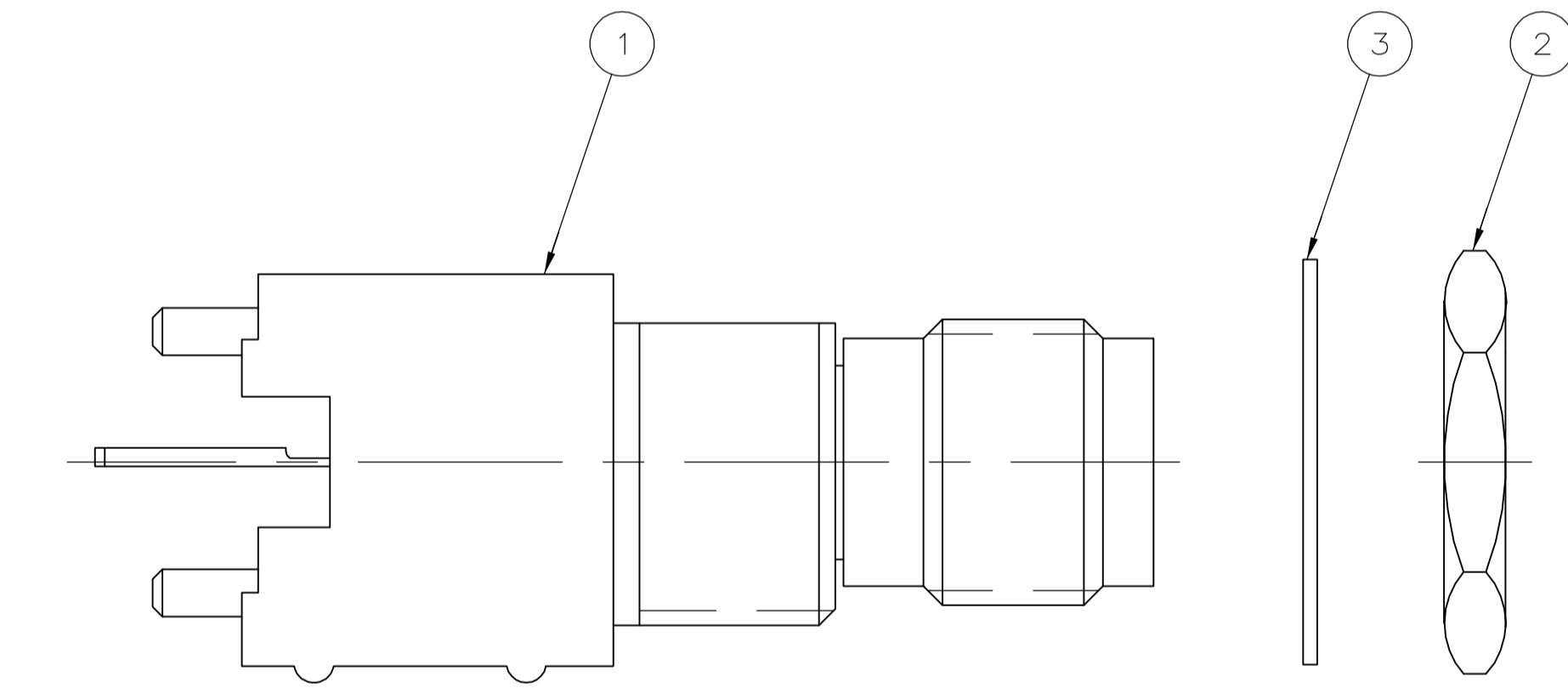

- 1 POLYESTER PBT PER MIL-M-24519, TYPE GPT-15F, UL94V-0 RATED, COLOR:NATURAL
- 2 POLYMETHYLPENTENE, GENERAL PURPOSE.
- 3 ZINC PER QQ-Z-363.
- 4 PHOSPHOR BRONZE PER QQ-B-750.
- 5 BRASS PER QQ-B-626.
- 6 NICKEL PLATE PER QQ-N-290, 3.81 μm [.000150] MINIMUM THICK.
- 7 TIN PLATE PER ASTM-B-545, 3.81 μm [.000150] MINIMUM THICK.
- 8 GOLD PLATE PER MIL-G-45204, 0.76 μm [.000030] MINIMUM THICK.
- 9 SILVER PLATE PER QQ-S-365, 2.54 μm [.000100] MINIMUM THICK.
- 10 PARTS PACKAGED UNASSEMBLED.

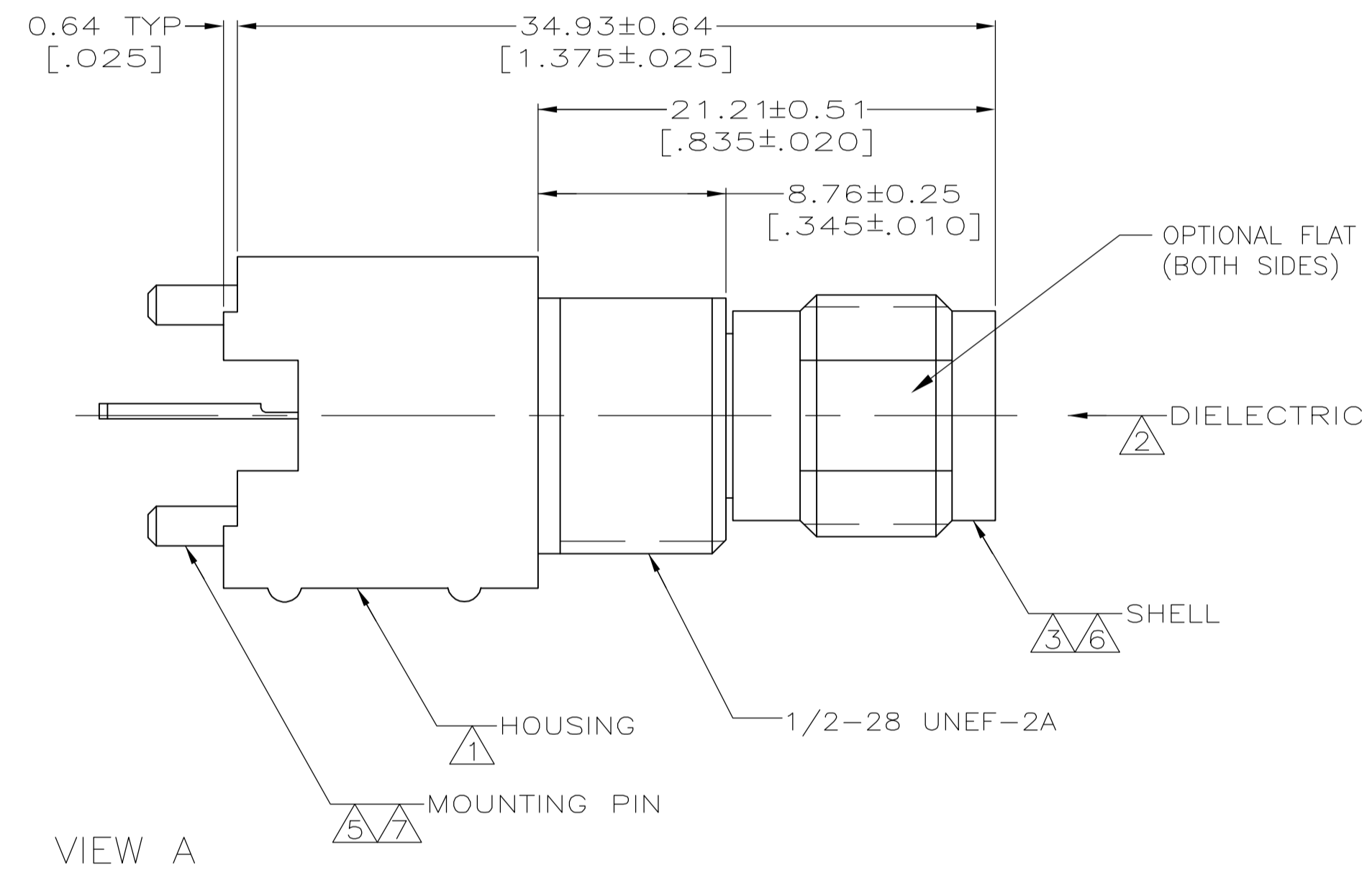
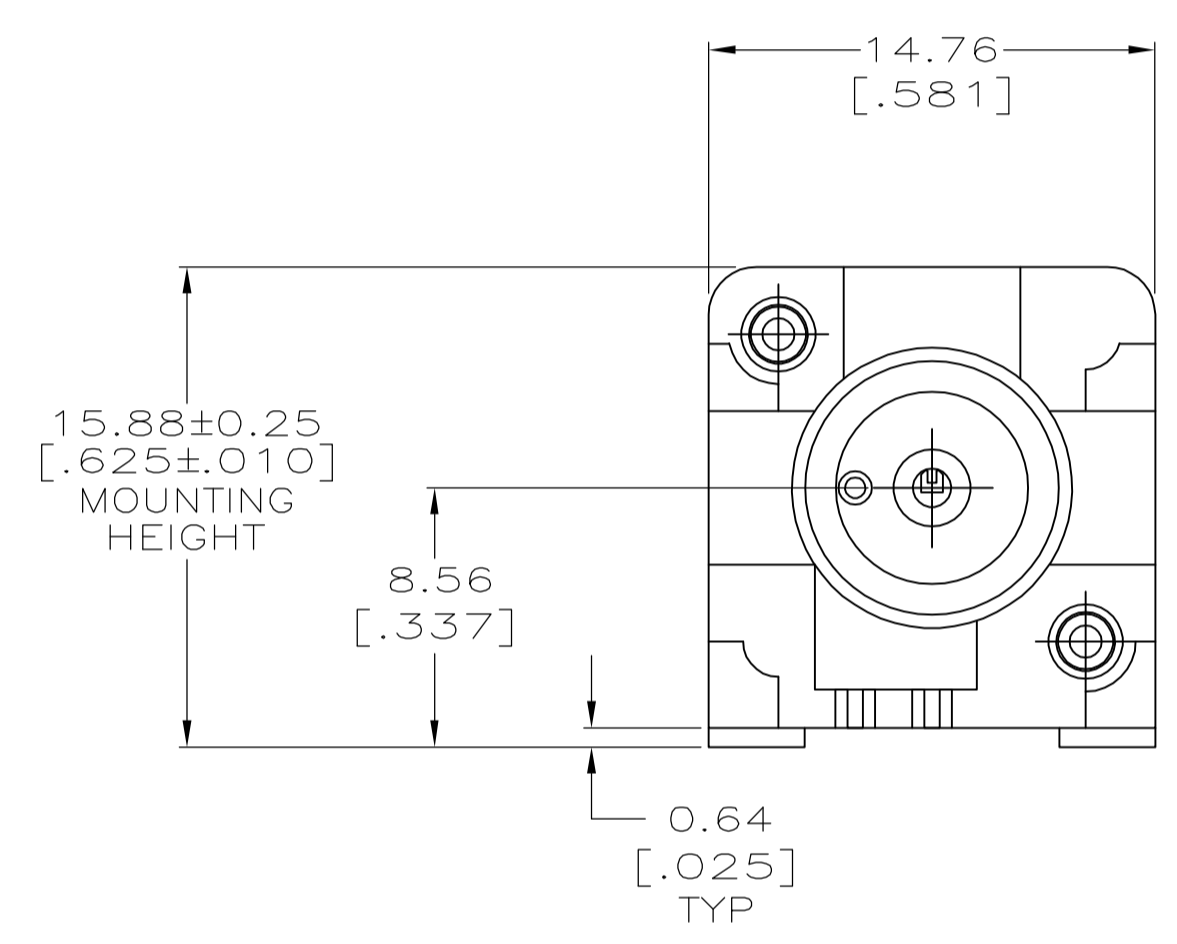
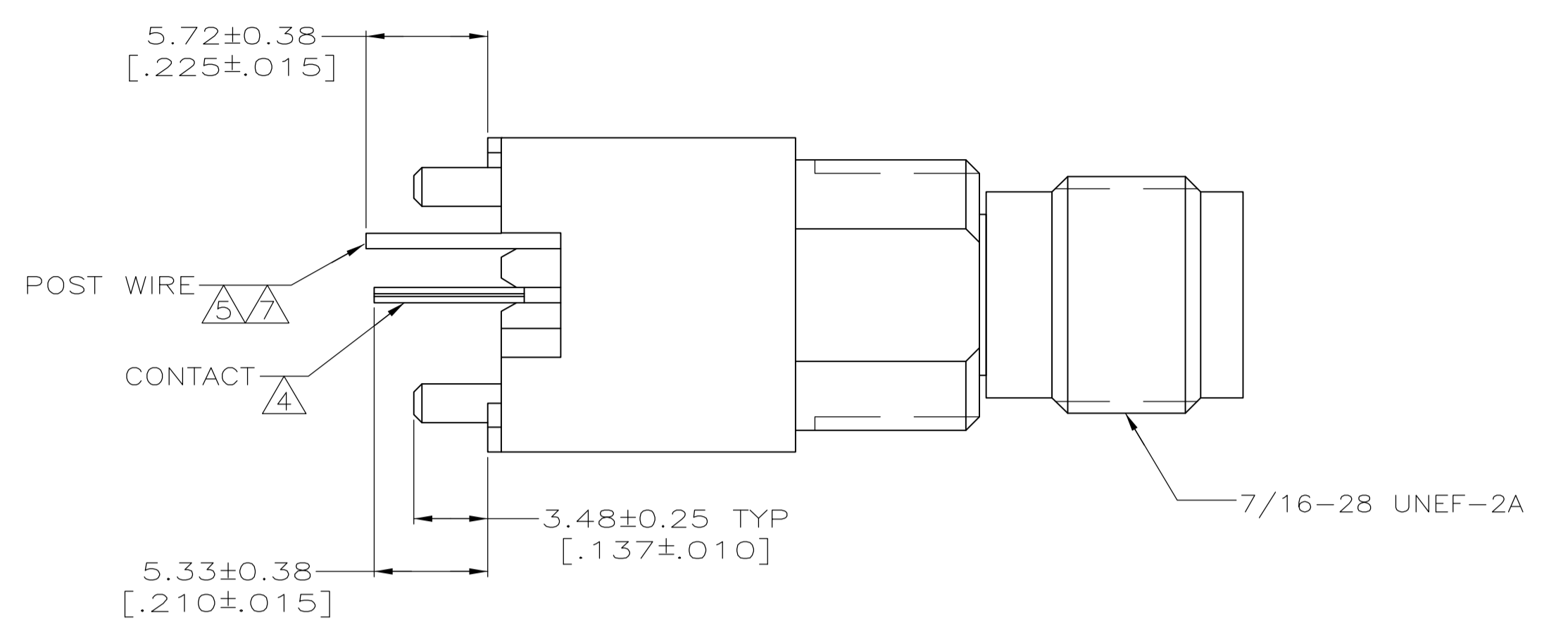
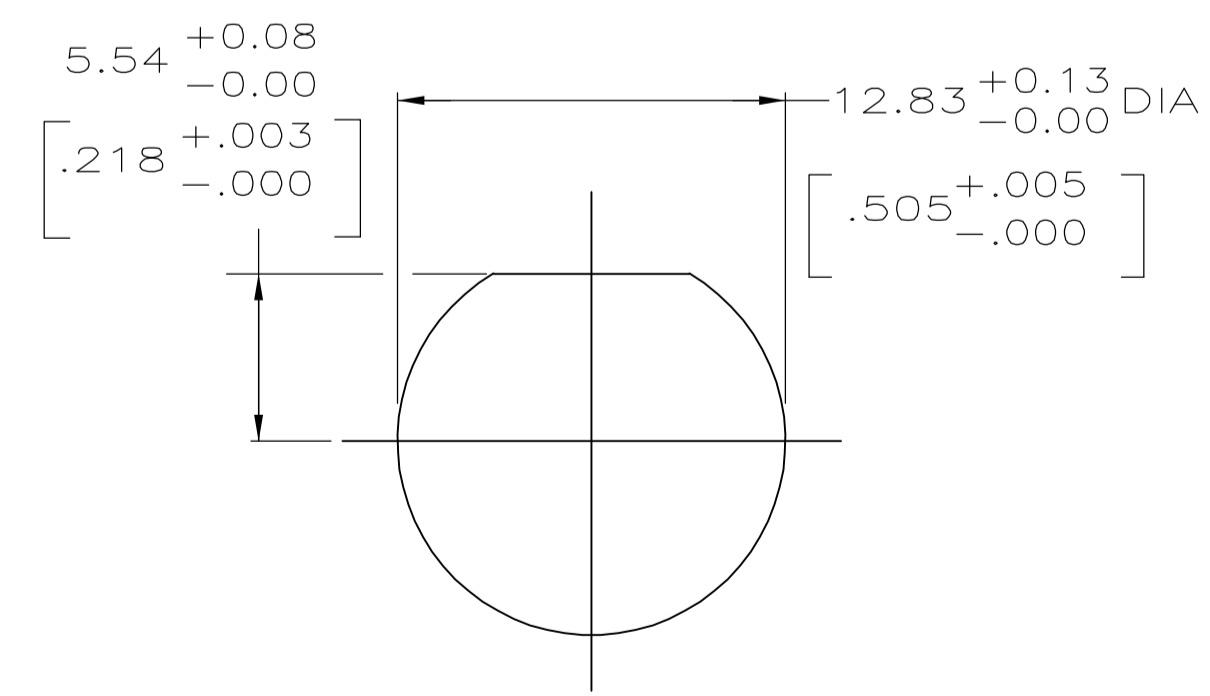

RECOMMENDED PANEL CUTOUT

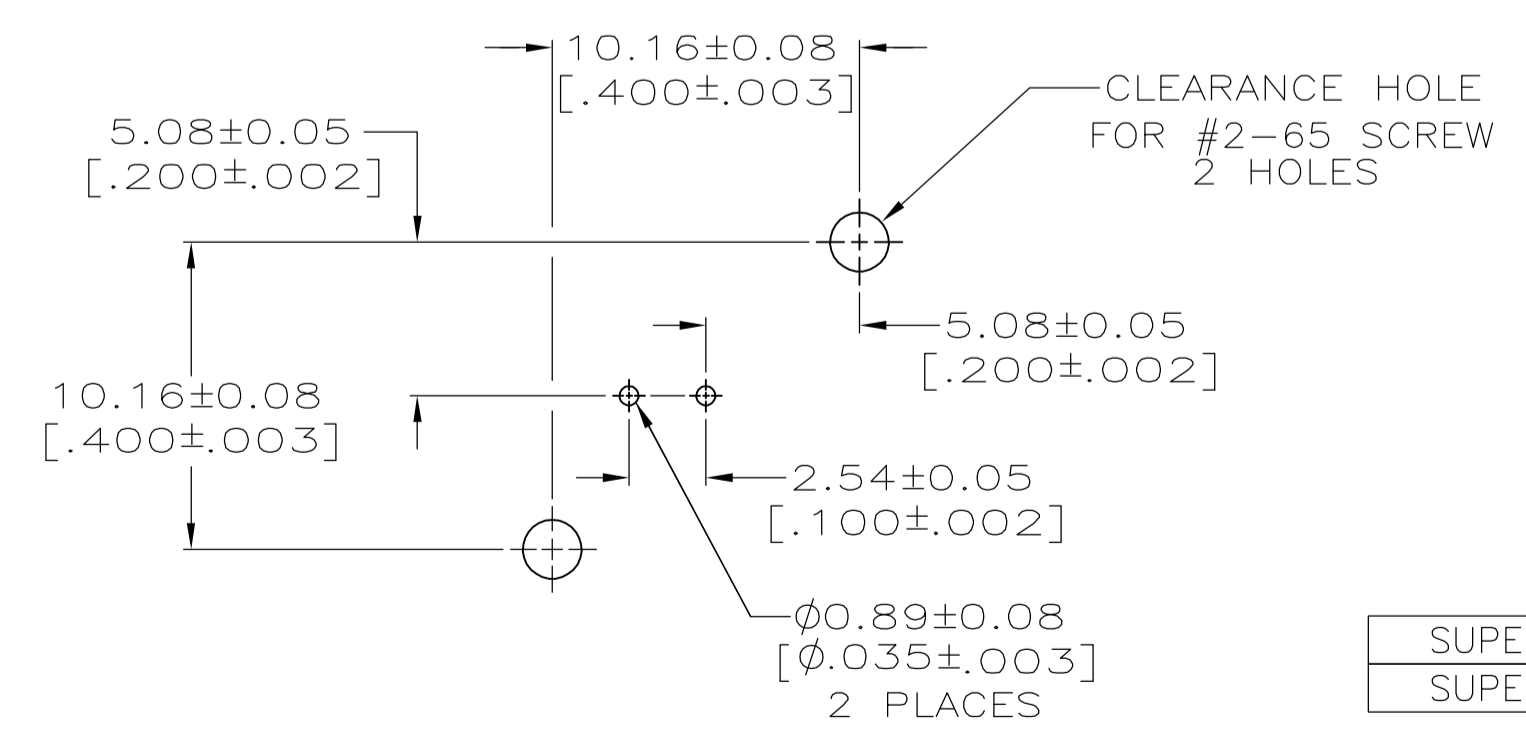

PCB CONFIGURATION

SUPERSEDED BY 227820-1	-	1-329632-2	1-329631-2	227820-1	B	227820-4
SUPERSEDED BY 227820-1	-	-	-	-	A	227820-2
CONTACT FINISH	3 LOCKWASHER QTY=1	2 JAM NUT QTY=1	1 JACK ASSY QTY=1	VIEW	PART NUMBER	

THIS DRAWING IS A CONTROLLED DOCUMENT.

DIMENSIONS: INCHES	TOLERANCES UNLESS OTHERWISE SPECIFIED:	DIN J. LIPPERT 10-29-91	Tyco Electronics Corporation Middletown, PA 17057
0 PLC ± -	1 PLC ± -	10-31-91	
2 PLC ± ± 0.20 [.008]	3 PLC ± ± -	APVD A. GABANY 10-31-91	NAME
4 PLC ± ± -	ANGLES ± ± -	PRODUCT SPEC	JACK, VERTICAL, PCB, SERIES TNC
MATERIAL SEE NOTES 1-5	FINISH SEE NOTES 6-9	SIZE	CAGE CODE DRAWING NO
		WEIGHT	A1 00779 C=227820
		CUSTOMER DRAWING	SCALE 4:1 SHEET 1 OF 1 REV J1