

REVISIONS				
P.	LTH	DESCRIPTION	DATE	APVD
A		RELEASED PER ECO-16-004159	11MAR2016	VP DS

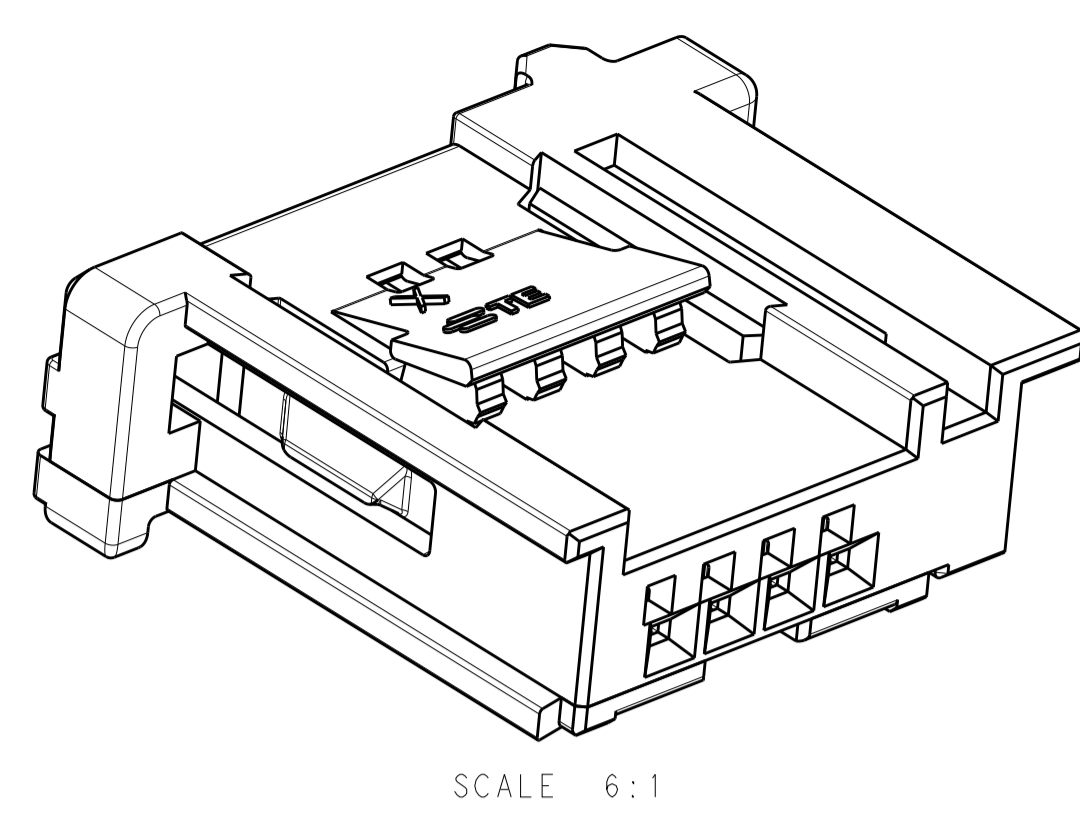

- 1. MATERIAL: PBT, 15% GLASS FILLED
- 2. ALL DIMENSIONS SHOWN ON THIS DRAWING ARE REFERENCE ONLY AND ARE SUBJECT TO CHANGE WITHOUT NOTICE.
- 3. THIS CONNECTOR INTENDED FOR USCAR-2, REV 5, TEMP CLASS 2, VIBRATION CLASS 1.
- 4. CONNECTOR COMPLIES WITH USCAR-25, REV 1, CLASS 2
- 5. CONNECTOR USED WITH FEMALE TERMINAL P/N 2098583
- 6. THIS CONNECTOR HAS NOT BEEN SUBJECTED TO PRODUCT VALIDATION TESTING.
- 7. NOT PRODUCTION TOOLED. NOT TESTED.

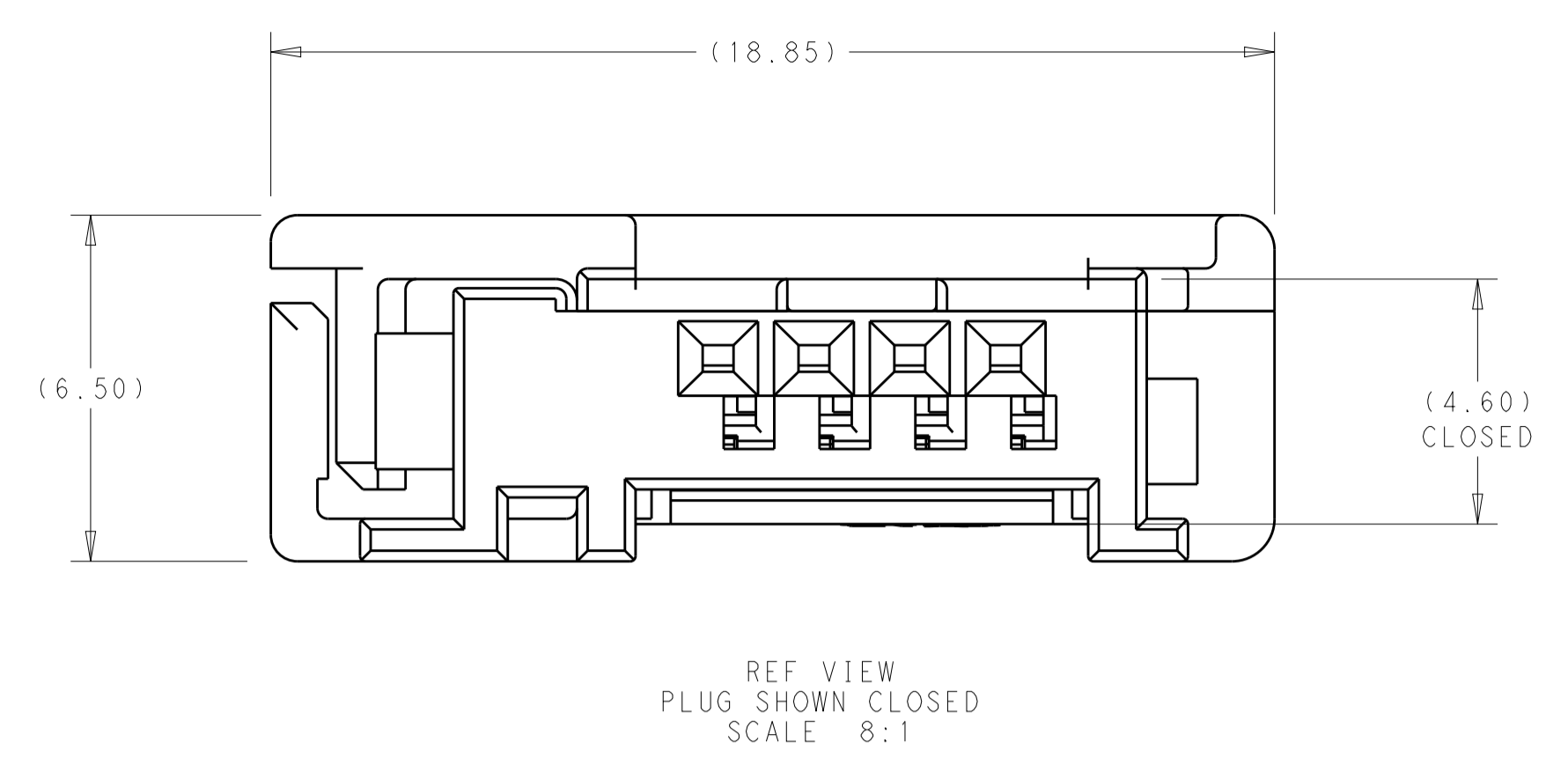
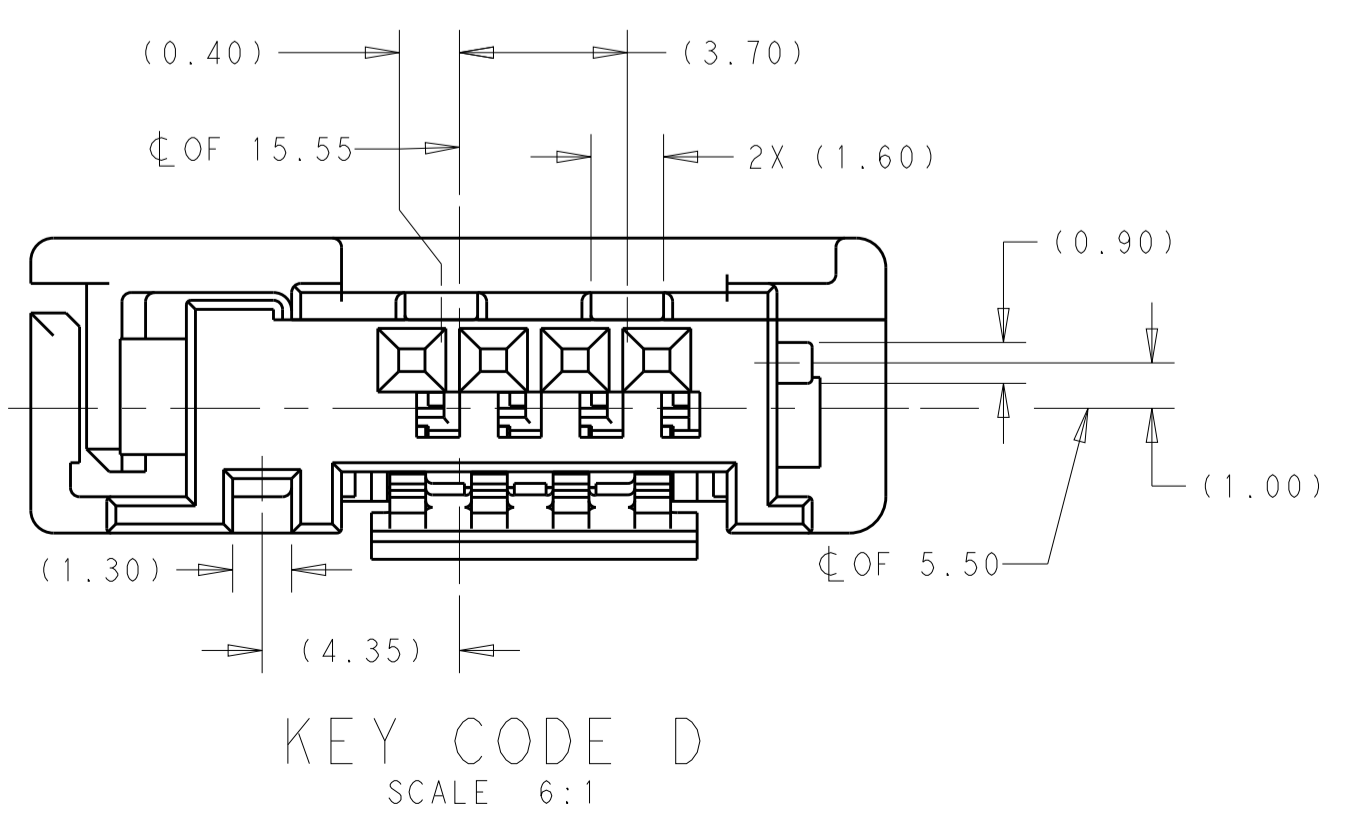
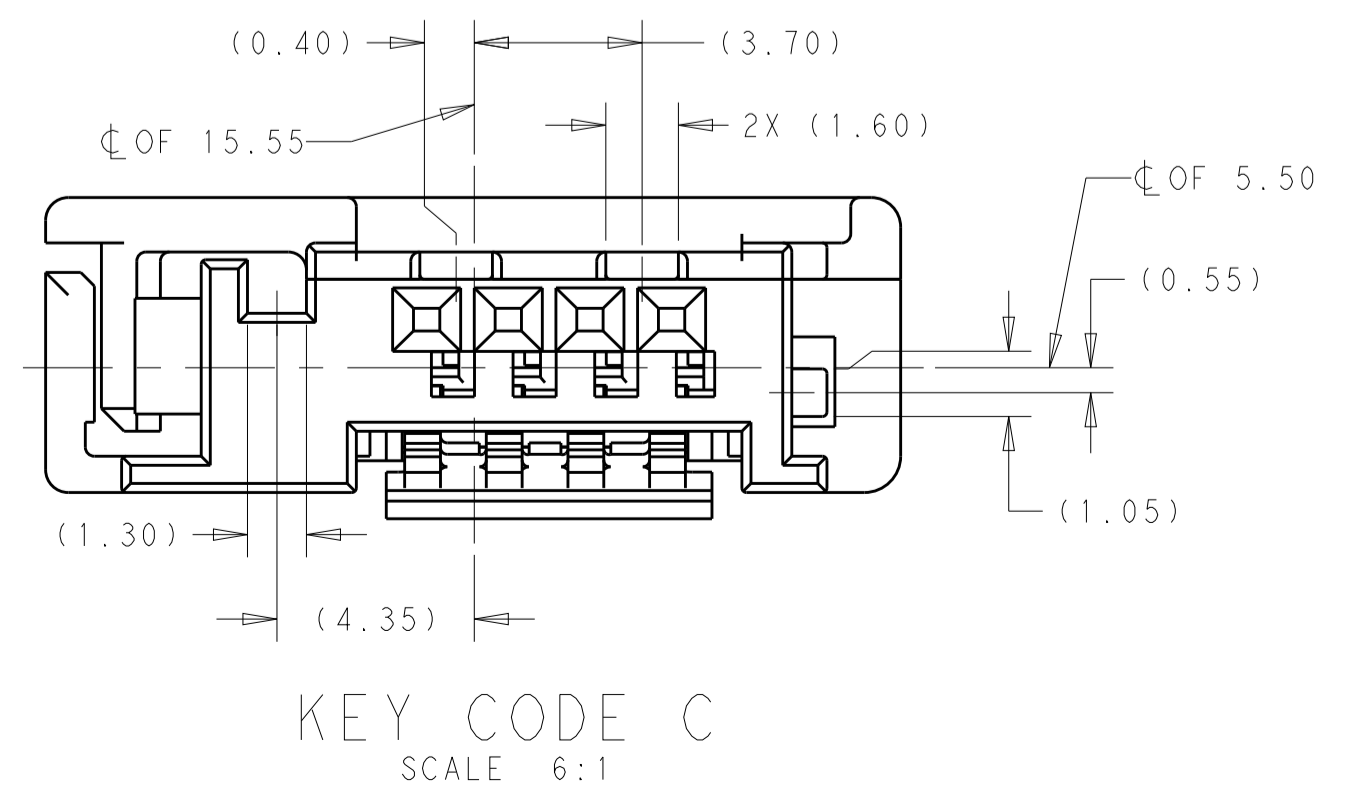
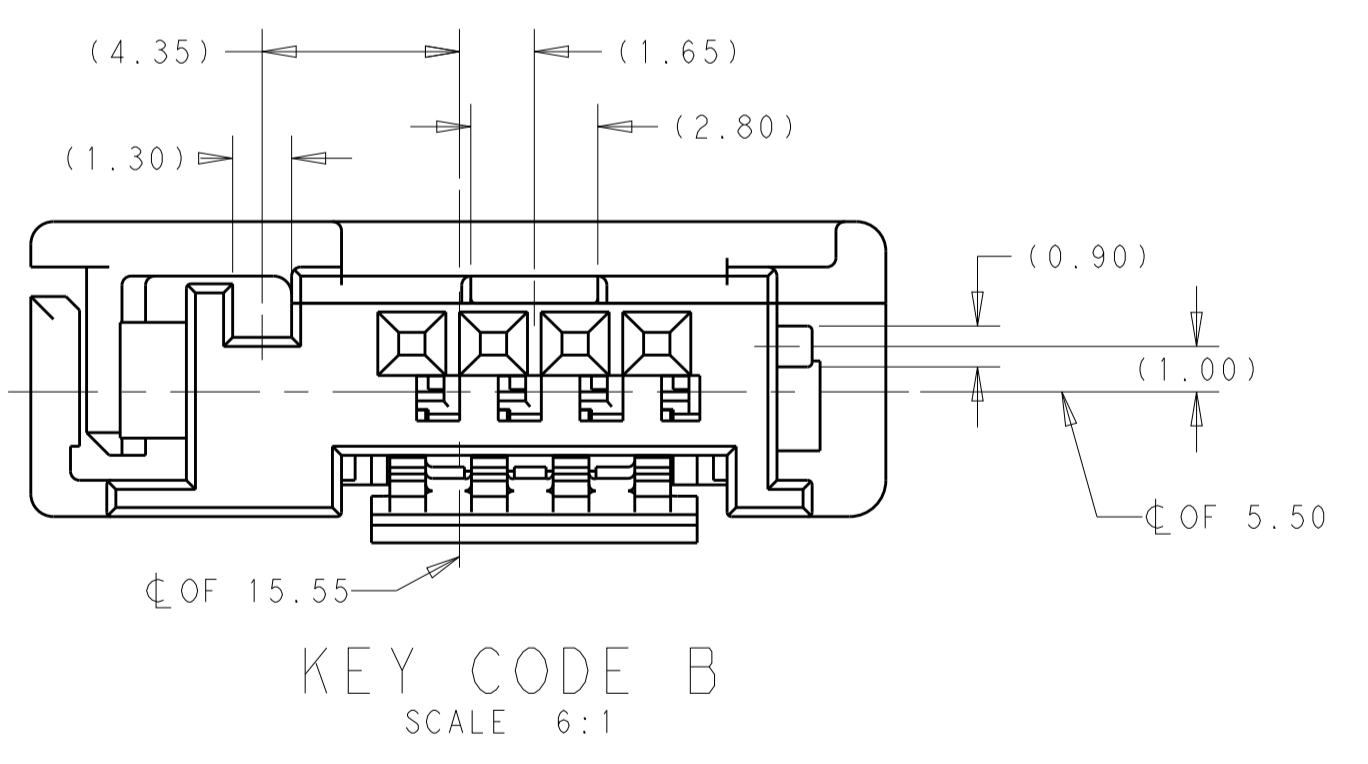
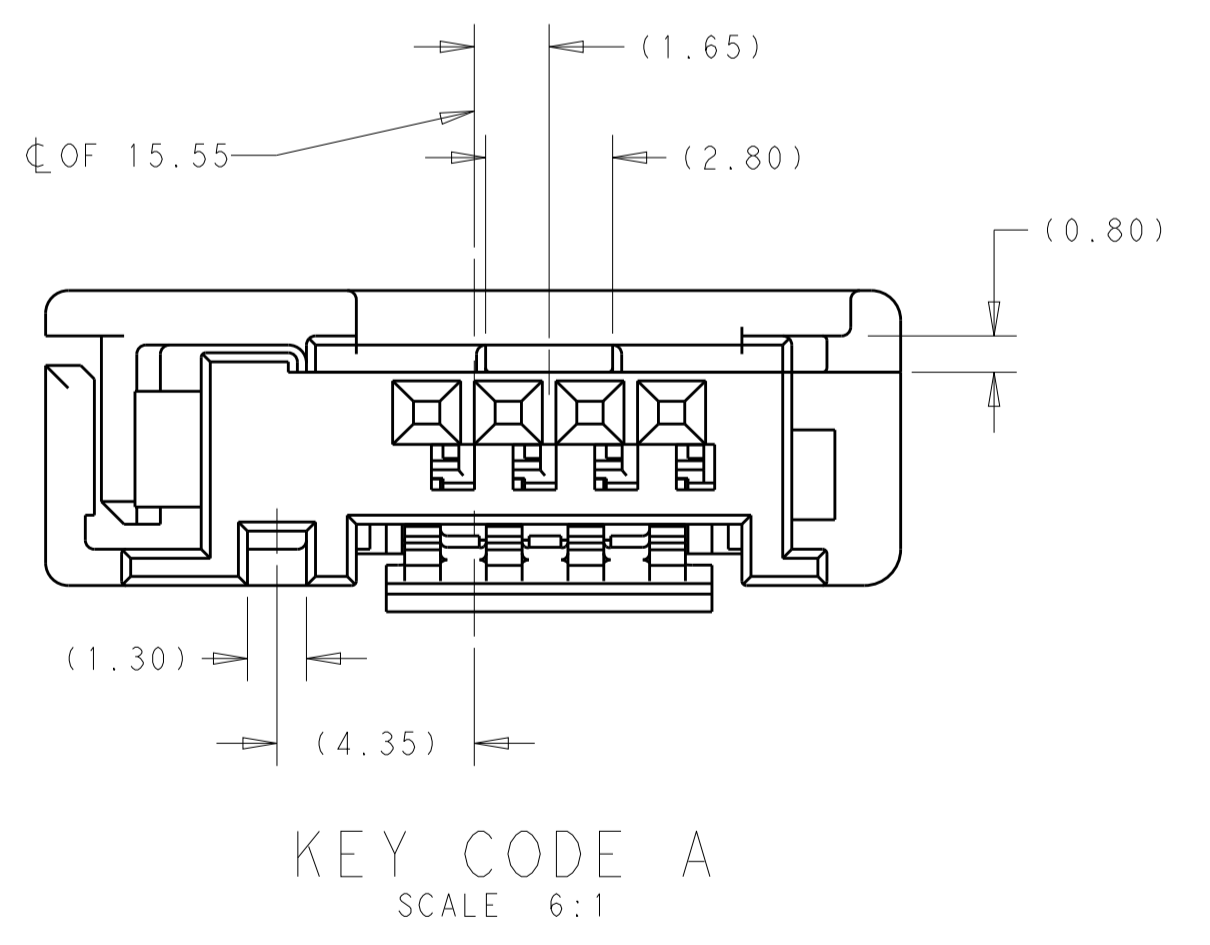
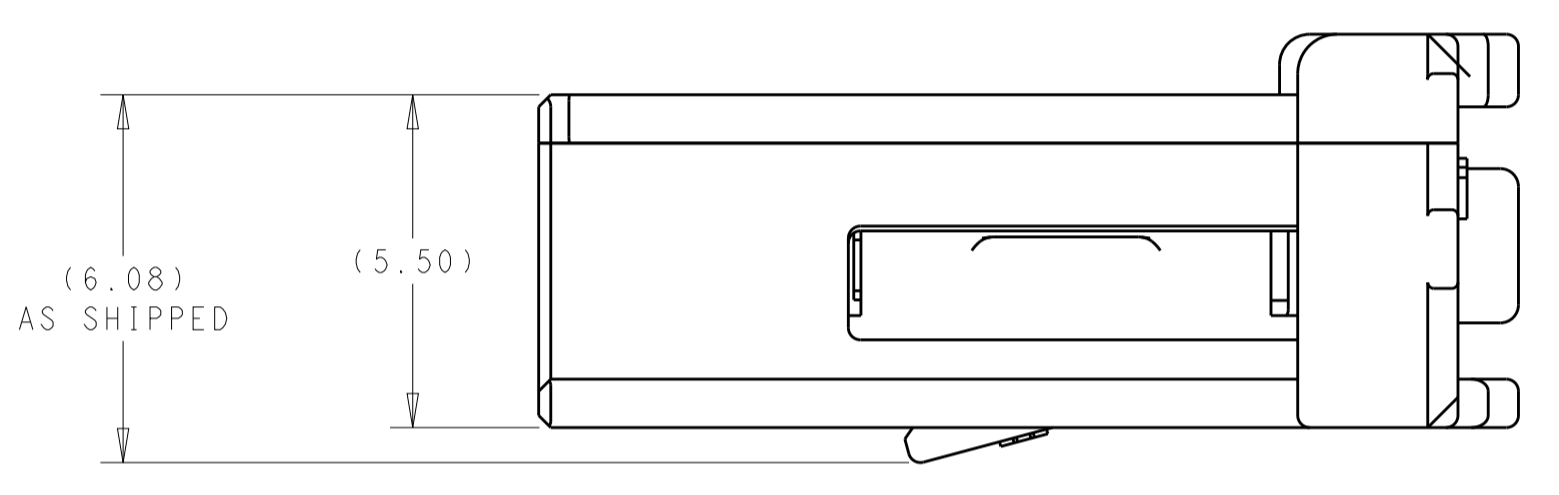
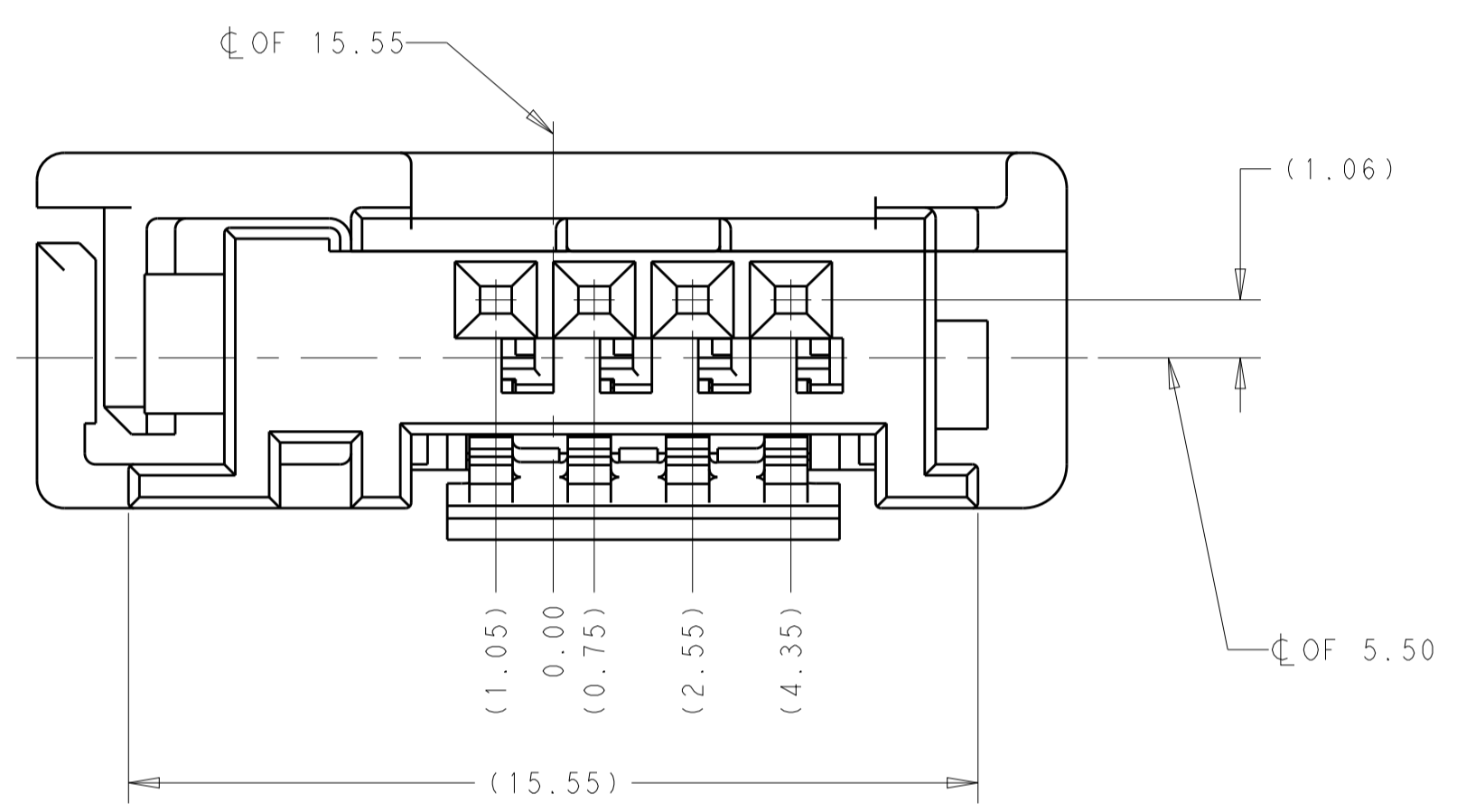

KEY CODE D	2272399-4
KEY CODE C	2272399-3
KEY CODE B	2272399-2
KEY CODE A	2272399-1
KEY CODE	PART NUMBER

THIS DRAWING IS A CONTROLLED DOCUMENT. DWN: H. MOLL 21MAR2014
 CHK: D. FRY 20OCT2015
 APVD: D. FRY 20OCT2015

STE TE Connectivity

NAME: PLUG ASSEMBLY, 4 POSITION, 1.80 CENTERLINE, UNSEALED, GENERATION 50

PRODUCT SPEC: -
 APPLICATION SPEC: -
 SIZE: - CAGE CODE: - DRAWING NO: A100779 ©=2272399
 WEIGHT: 1.0 g
 MATERIAL: - FINISH: -
 CUSTOMER DRAWING

SCALE 8:1 SHEET 1 OF 1 REV A