

REVISIONS				
P	LTR REV	DESCRIPTION MODIFICATIONS	DATE	DWN DESS. APP.
	1	Original	20JUN2016	YJH SS

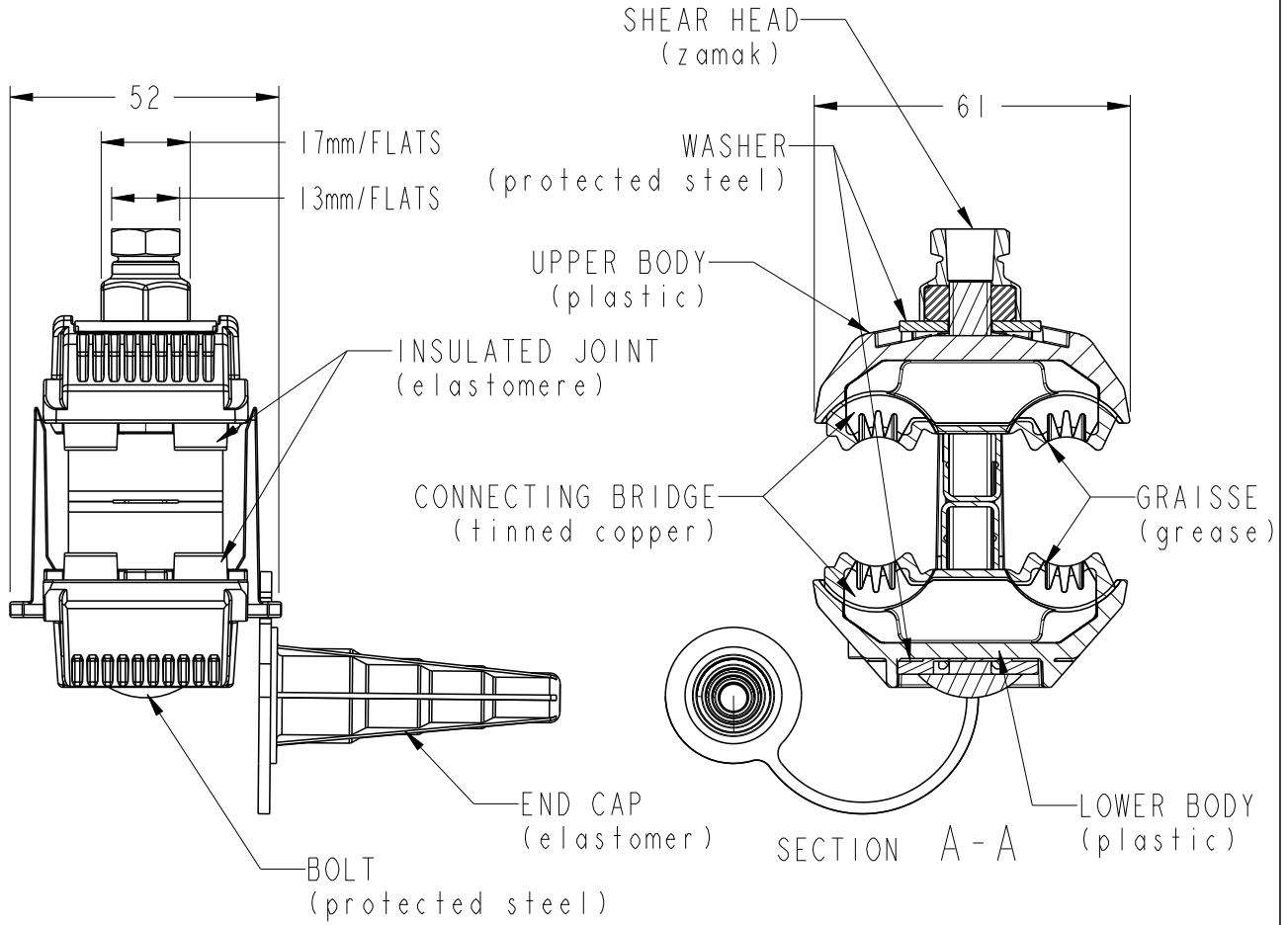

2011

RELEASED FOR PUBLICATION
LIBRE A LA DIFFUSION

ALL RIGHTS RESERVED.
TOUS DROITS RESERVES.

THIS DRAWING IS UNPUBLISHED.
DIFFUSION RESTREINTE

BY -

© COPYRIGHT 2011

Description	PN	CAPACITIES MAIN mm ²	CAPACITIES TAP mm ²	BREAKING SHEAR HEAD TORQUE
KZ3-95	2259231-1	25 to 95	25 to 95	18Nm
KZ3-95 EMEA	2259231-2	25 to 95	25 to 95	18Nm

DIMENSIONS: mm TOLERANCES UNLESS OTHERWISE SPECIFIED: TOLERANCES NON SPECIFIEES (SUIV NB DE DECIMALES): 0 PLC/DEC: ±0 1 PLC/DEC: ±0 2 PLC/DEC: ±0 3 PLC/DEC: ±0 4 PLC/DEC: ±0 ANGLES ±-	DWN/DESSINE YAN JIAHUA 20JUN2016	MATERIAL MATIERE -	FINISH FINITION -		
	CHK/VERIFIE WANG JUNFENG 20JUN2016	 TE Connectivity			
APVD/APPROUVE STEVEN SHI 20JUN2016	NAME TITRE KZ3-95				
PRODUCT SPEC SPEC. PRODUIT -	APPLICATION SPEC SPEC. APPLICATION -	SIZE FORMAT A4	CAGE CODE -	DRAWING NO No PLAN C=2259231	RESTRICTED TO RESERVE A -
WEIGHT MASSE APPROX. 170g	CUSTOMER DRAWING /PLAN CLIENT				
		UNIQUEMENT POUR REFERENCE	SCALE ECHELLE 1:2	SHEET FEUILLE OF DE 1	REV