

LOC		DIST		REVISIONS			
P	LTN	DESCRIPTION	DATE	DMN	APVD		
A		RELEASED PER ECO-13-011062	16SEP2013	BC	DD		

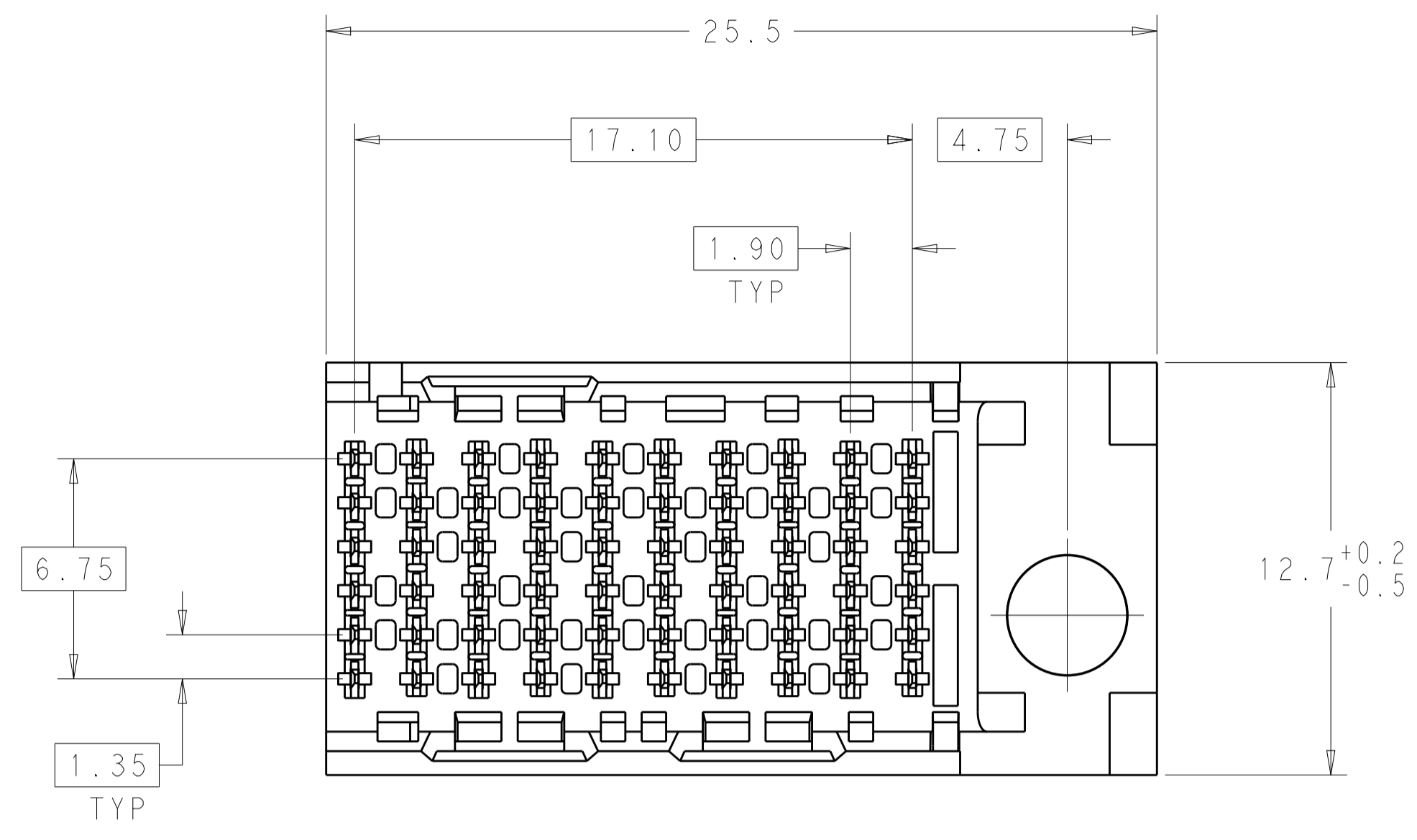

NOTCH DESIGNATES ROW A

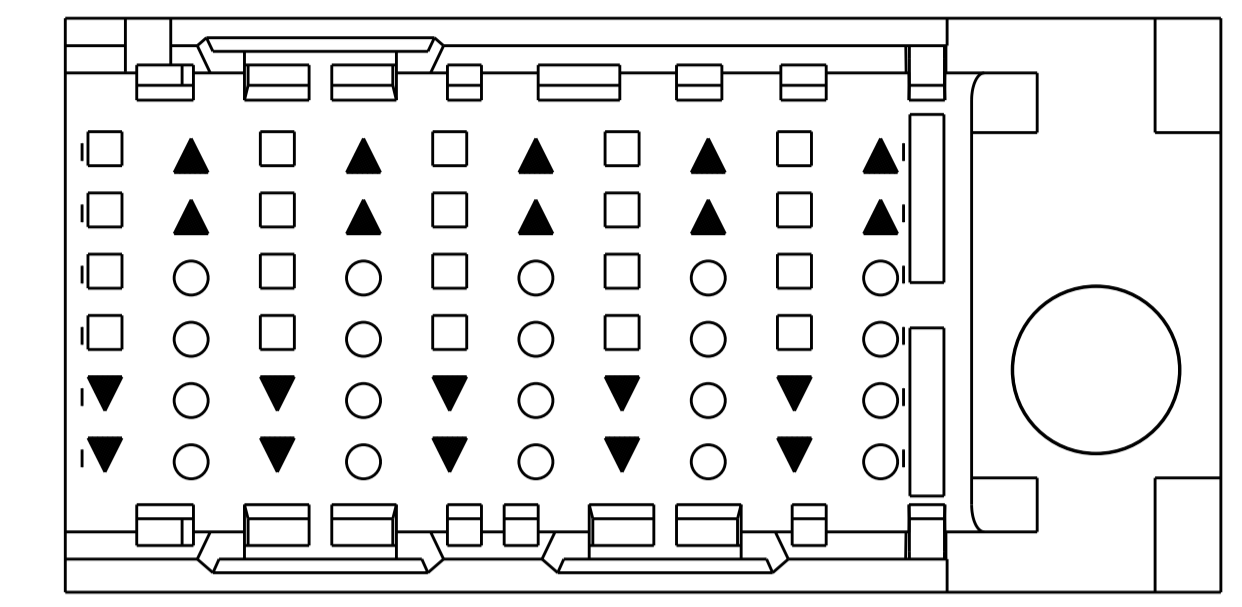
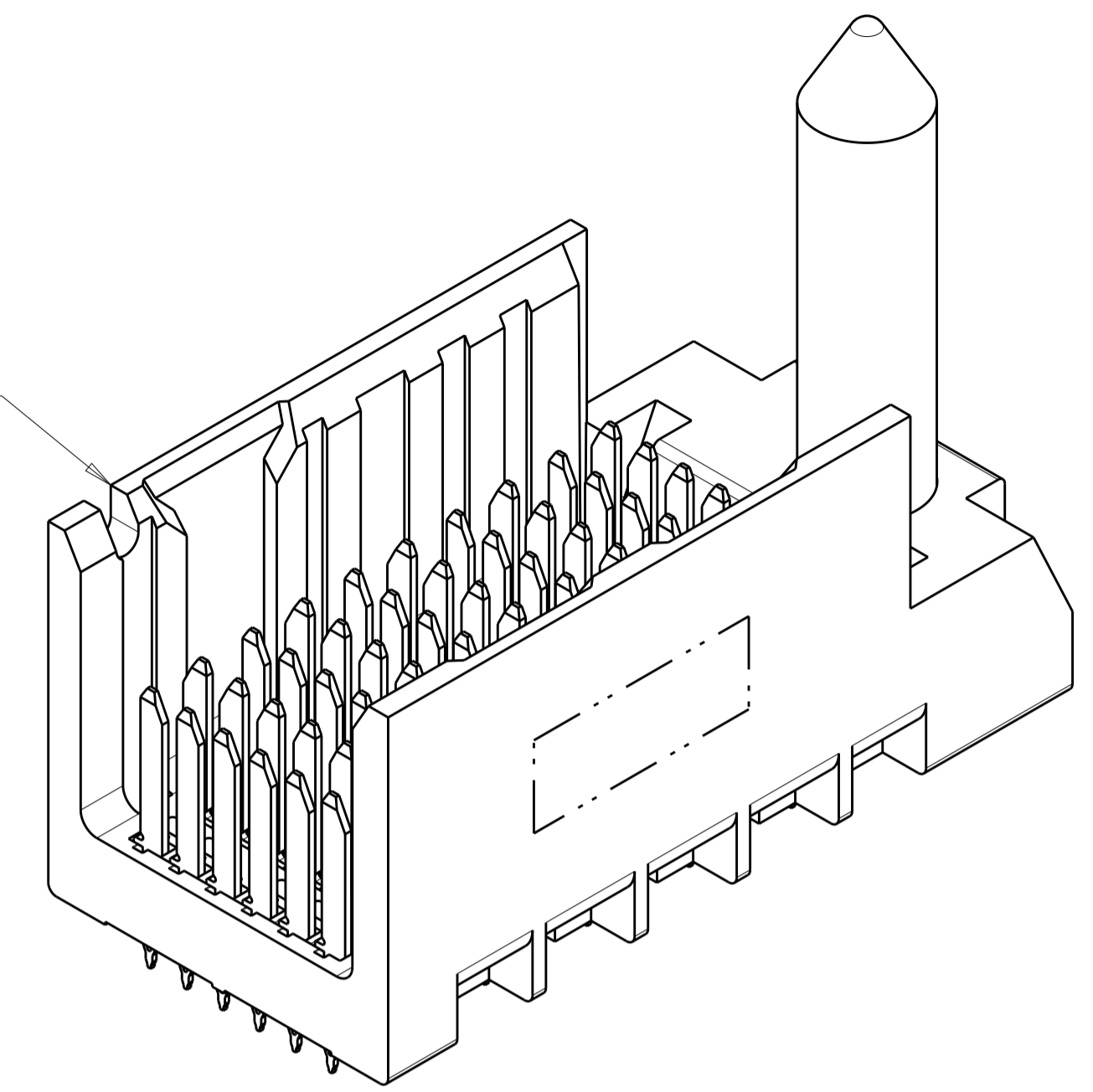

SYMBOL	DESCRIPTION
□	LEFT STITCH STANDARD
▼	LEFT STITCH ORPHAN
○	RIGHT STITCH STANDARD
▲	RIGHT STITCH ORPHAN

CONTACT STITCHING PATTERN
SCALE 6:1

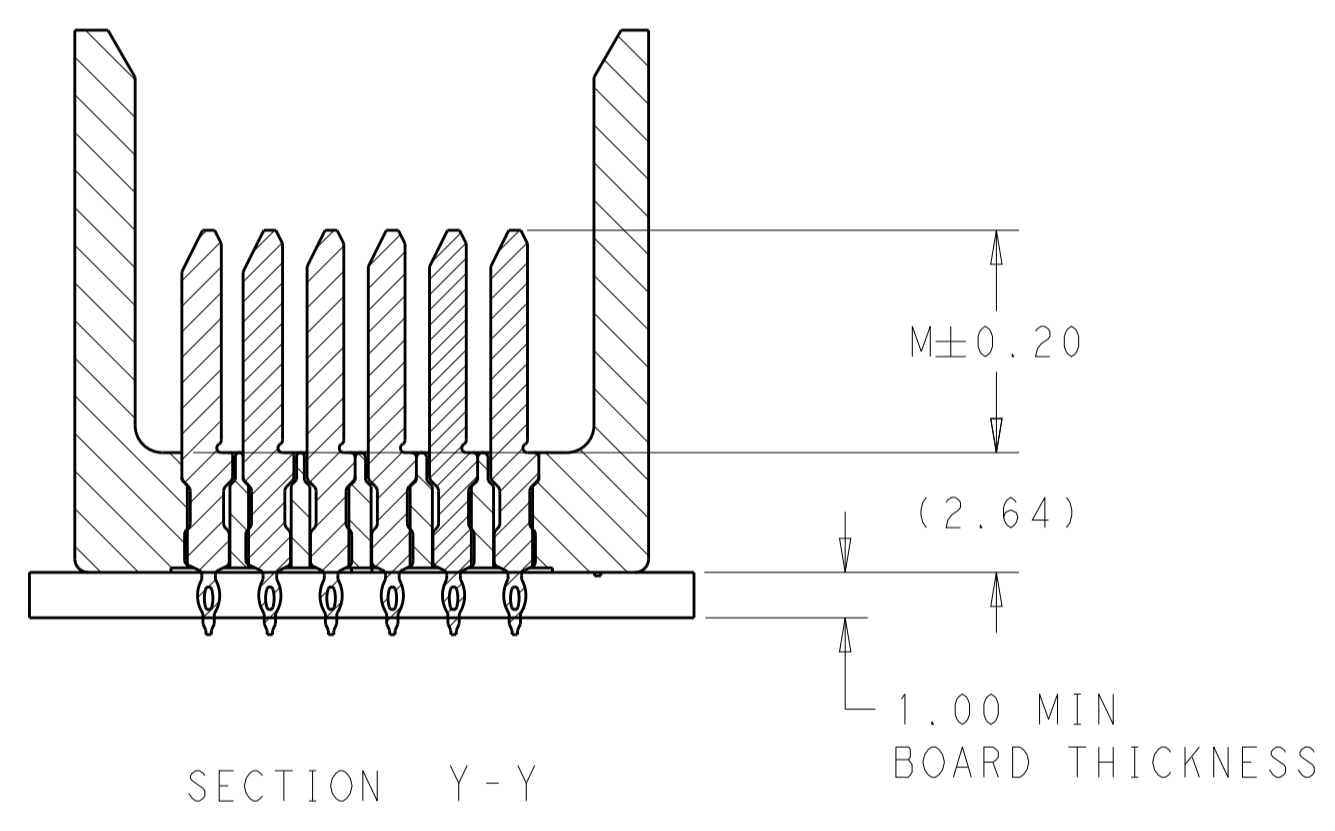
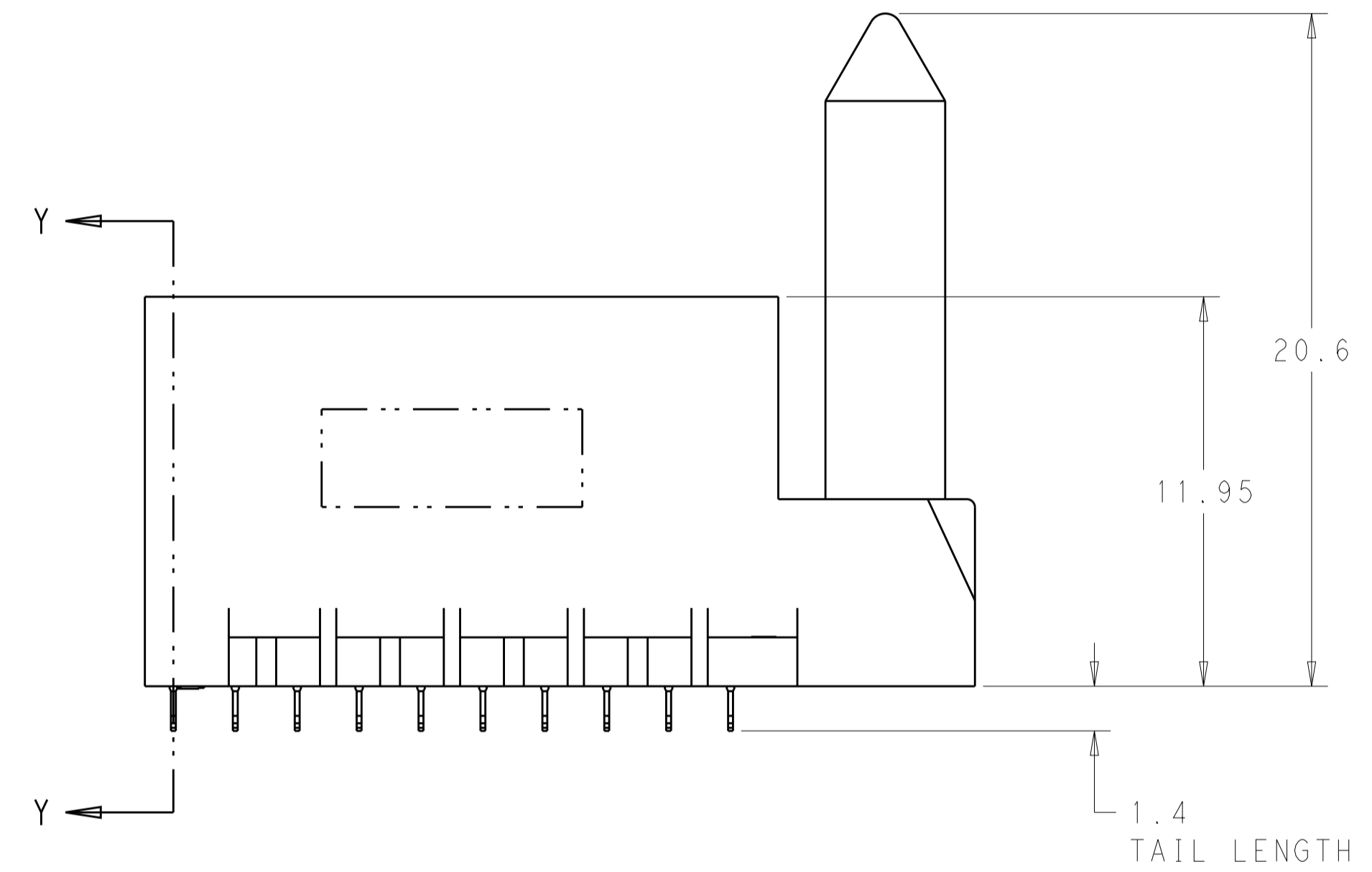

- 1 MATERIAL:
HOUSING: LCP, GLASS FILLED, UL94V-0 RATED.
TERMINALS: HIGH PERFORMANCE COPPER ALLOY.
- 2 FINISH:
30µm MIN GOLD IN CONTACT AREA, SELECTIVE TIN ON PCB TAILS, NICKEL OVERALL.
- 3. SCREWS PACKAGED IN END OF PACKAGING TUBE.
- 4 FOR GROUNDED GUIDE PIN USE $\varnothing 3.56 \pm 0.08$ PTH, $\varnothing 3.66$ DRILL, AND $\varnothing 6.5$ PAD.

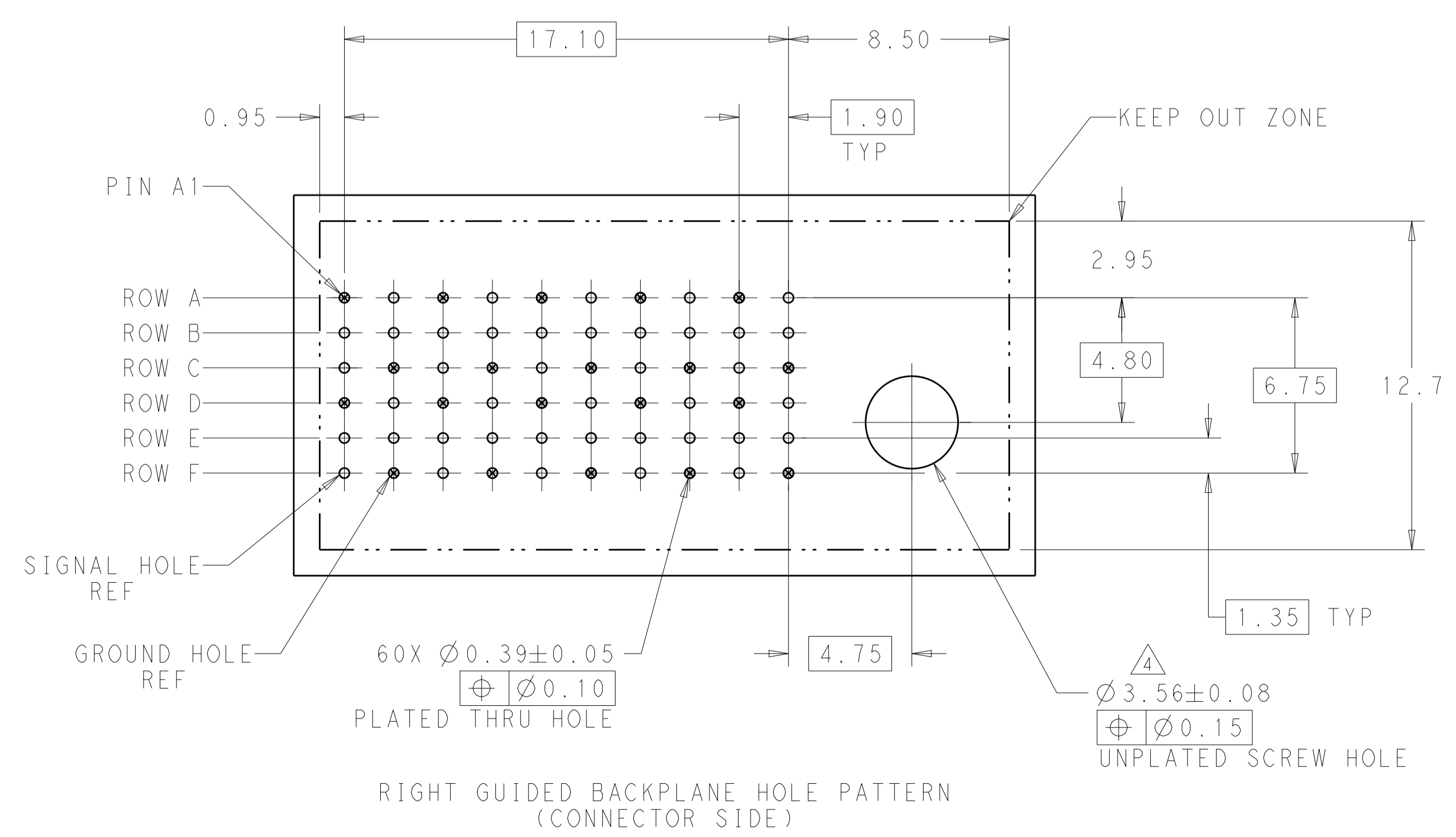

5.5	2214473-3
4.9	2214473-2
4.5	2214473-1
M	PART NUMBER
POST LENGTH	

THIS DRAWING IS A CONTROLLED DOCUMENT. DWN S.WELDON 03MAY2012
 CHK D.DIXON 03MAY2012
 APVD D.DIXON 03MAY2012

DIMENSIONS: mm
 TOLERANCES UNLESS OTHERWISE SPECIFIED:
 0 PLC ±
 1 PLC ±0.1
 2 PLC ±0.10
 3 PLC ±0.000
 4 PLC ±0.0000
 ANGLES ±

FINISH: 1 2

MATERIAL: 1 2

Customer Drawing

NAME: IMPACT, 2 PAIR, 10 COLUMN, HEADER, VERTICAL, RIGHT GUIDED, OPEN END, SIGNAL MODULE, 85 OHM

SIZE: A1
 CAGE CODE: 2214473
 DRAWING NO: 2214473

RESTRICTED TO: -

SCALE: 6:1 SHEET 1 OF 1 REV A