

LOC	DIST	REVISIONS			
		REV	DATE	BY	CHK
		A	2MAR2016	RG	SH
		B	14AUG2019	TX	SH

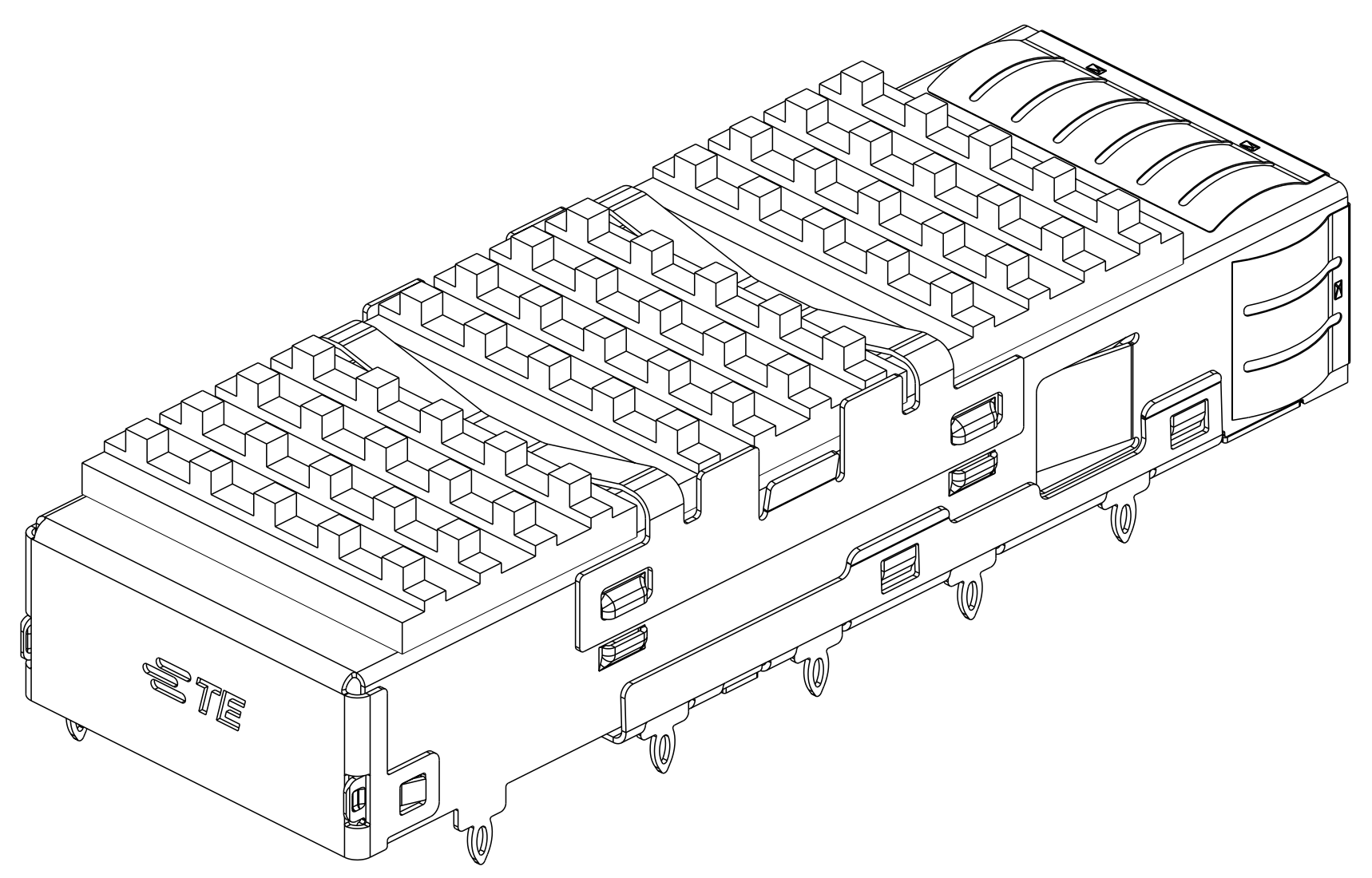

SCALE 4:1

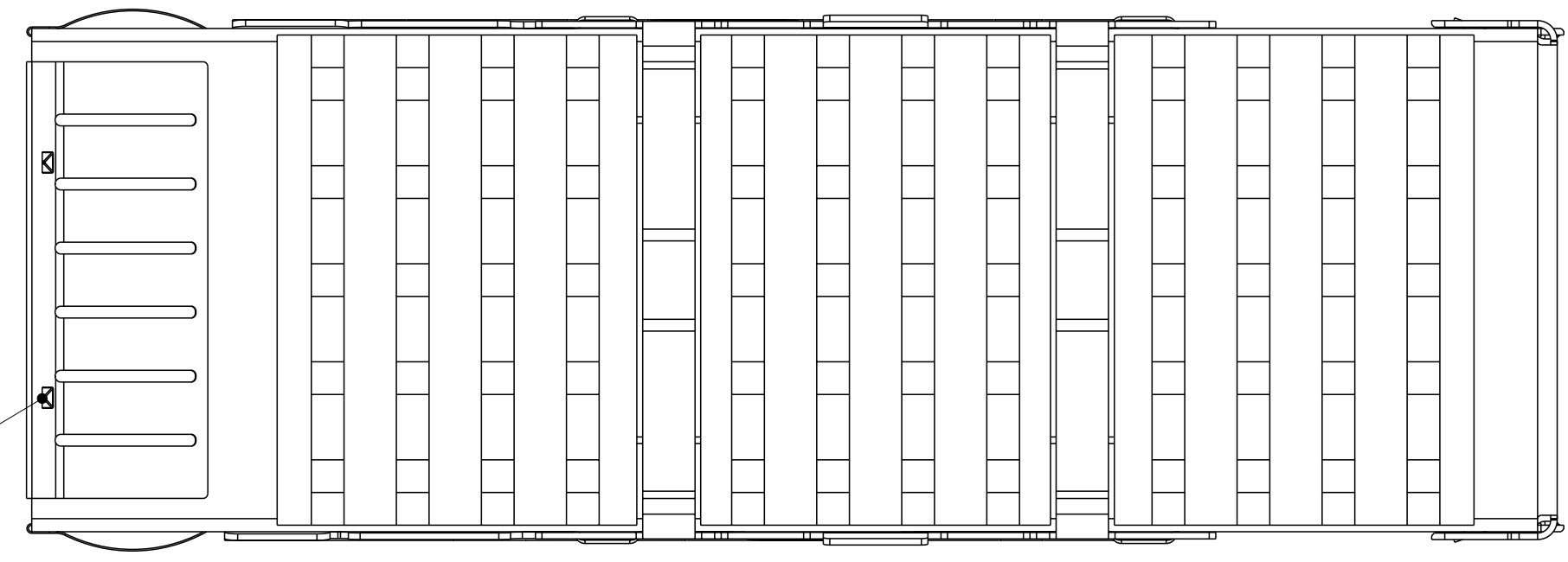

Sn42Bi58 SOLDER 6 PLACES

- 1. CAGE MATERIAL: NICKEL SILVER, 0.25mm THICK  
 HEAT SINK MATERIAL: ALUMINUM  
 HEAT SINK CLIP MATERIAL: STAINLESS STEEL  
 EMI SPRINGS MATERIAL: COPPER ALLOY
- 2. MINIMUM PITCH DIMENSION.
- 3. MATES WITH QSFP MSA COMPATIBLE TRANSCEIVER.
- 4. REFERENCE APPLICATION SPEC 114-13217 FOR RECOMMENDED DRILL HOLE DIAMETER AND PLATING THICKNESS.
- 5. DATUMS AND BASIC DIMENSIONS ESTABLISHED BY CUSTOMER.
- 6. MINIMUM PC BOARD THICKNESS:  
 SINGLE SIDED = 1.45mm (shown, pg. 4)  
 DOUBLE SIDED = 2.2mm
- 7. HEATSINK AND CLIP SHIPPED ASSEMBLED TO CAGE ASSEMBLY. CAGE ASSEMBLY MAY BE PRESSED INTO THE PCB AS SHIPPED.
- 8. DATUM -A- IS TOP SURFACE OF HOST BOARD.
- 9. SURFACE TRACES PERMITTED WITHIN THIS AREA EXCEPT WHERE CAGE STANDOFFS, SHOWN IN DETAIL J, CONTACT PC BOARD.
- 10. DIMENSION APPLIES WITH MODULE INSTALLED IN THE CAGE.
- 11. DATE CODE (YYWWD) MARKED ON TOP OF CAGE AND CONCEALED BY HEAT SINK APPLIES TO CAGE ASSEMBLY ONLY.
- 12. SPRING FINISH: 0.8µm MIN TIN OVER 0.8µm MIN NICKEL. NON-PLATED EDGES PERMISSIBLE. HEAT SINK FINISH: BLACK ANODIZED.

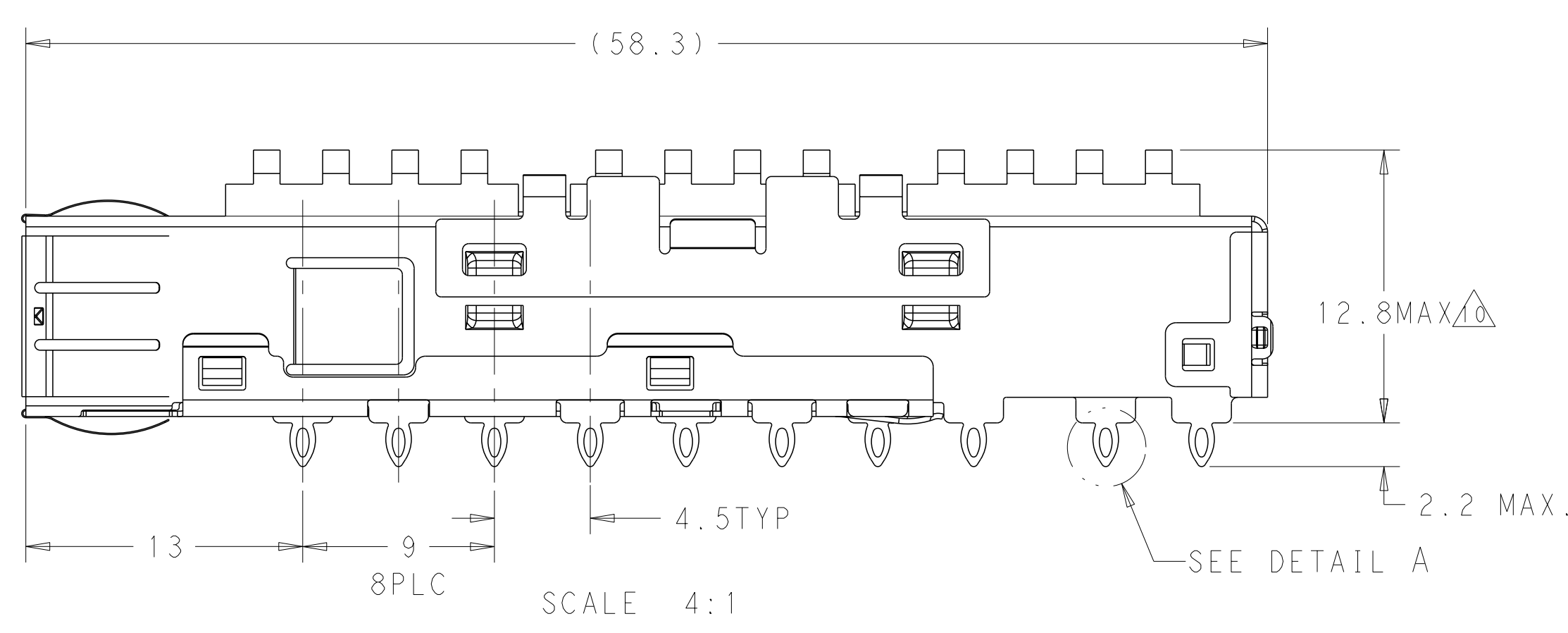
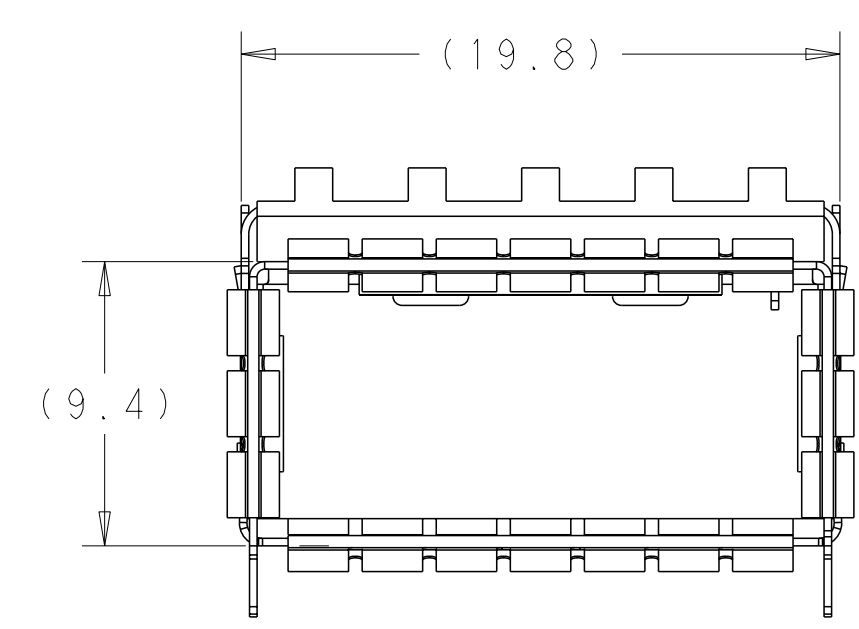

SCALE 4:1

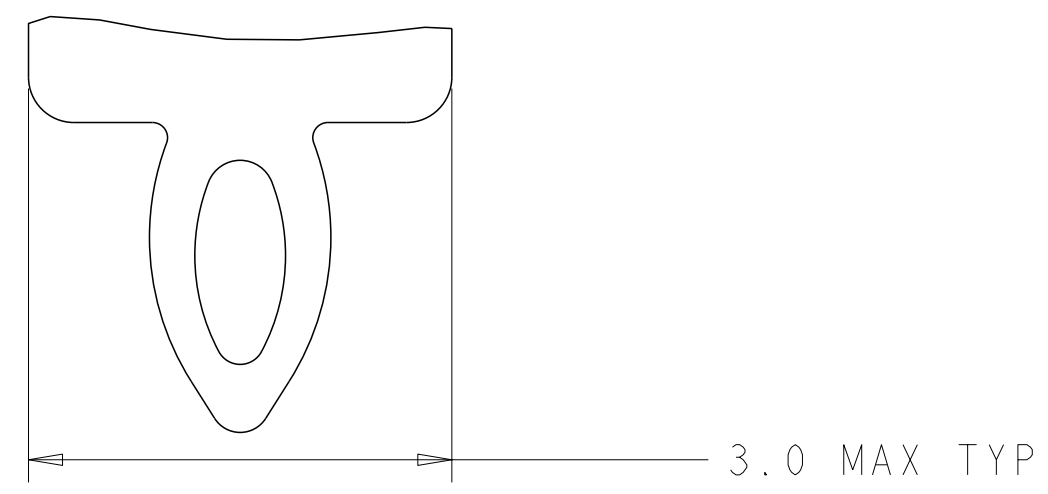

DETAIL A  
SCALE 20:1

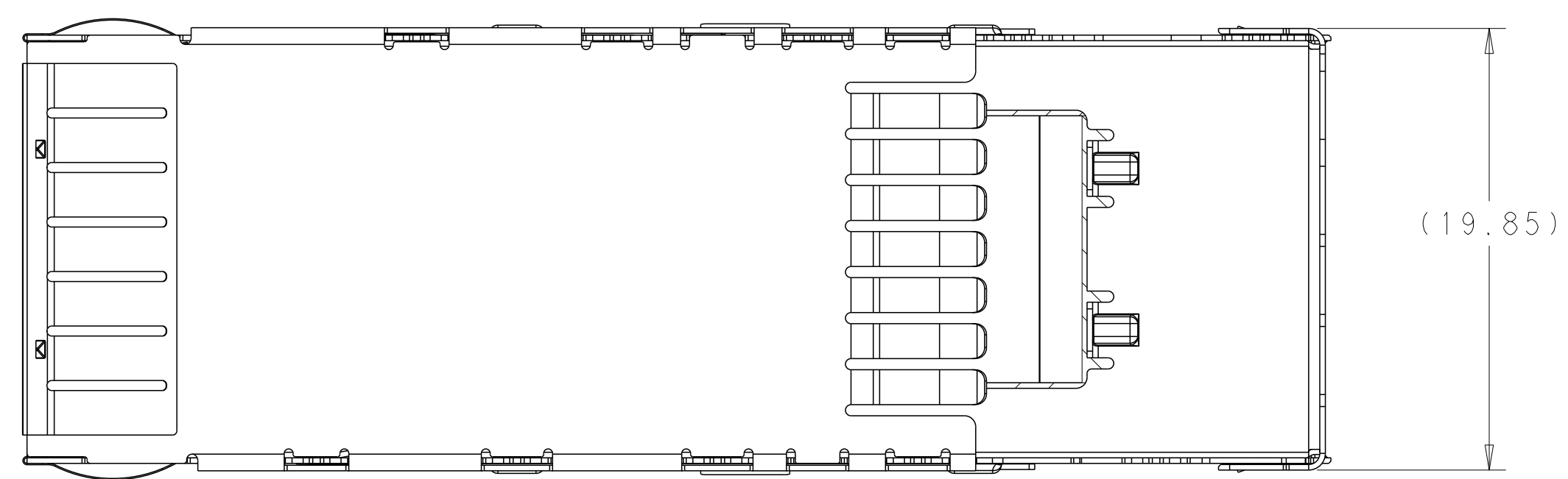

PCI	1-2170536-1
DESCRIPTION	PART NUMBER

THIS DRAWING IS A CONTROLLED DOCUMENT.		OWN: HANK WU 27APR2013	TE Connectivity NAME: CAGE ASSEMBLY, THRU BEZEL, QSFP, WITH HEAT SINK PRODUCT SPEC: 108-2286 APPLICATION SPEC: 114-13217	SIZE: CAGE CODE DRAWING NO: A100779C=2170536	RESTRICTED TO: -	
DIMENSIONS:	TOLERANCES UNLESS OTHERWISE SPECIFIED:	CHK: JASON YANG 27APR2013		WEIGHT: -	SCALE: 2:1	SHEET 1 OF 4
mm	0 PLC ±0.25 1 PLC ±0.13 2 PLC ±0.13 3 PLC ±0.13 4 PLC ±0.13	APVD: ALEY CAI 27APR2013		CUSTOMER DRAWING	REV: B	
	ANGLES FINISH					

THIS DRAWING IS UNPUBLISHED. RELEASED FOR PUBLICATION 20  
 © COPYRIGHT 20 BY - ALL RIGHTS RESERVED.

LOC		DIST		REVISIONS			
				REV	DATE	BY	APPV
-	-	-	-	1	SEE SHEET 1	-	-

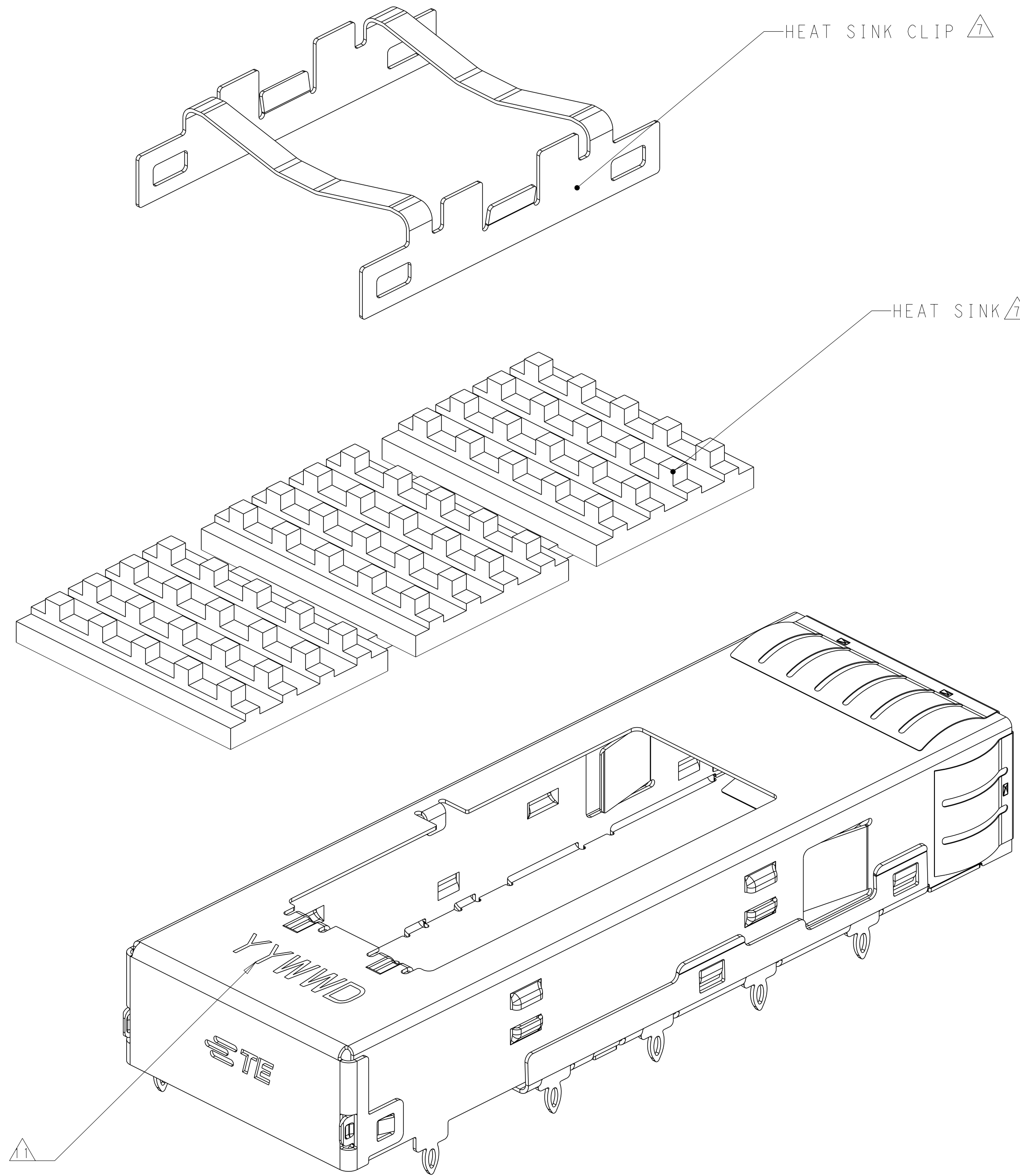

SCALE 5:1

THIS DRAWING IS A CONTROLLED DOCUMENT.		OWN: HANK WU 27APR2013	 TE Connectivity
DIMENSIONS: mm		CHK: JASON YANG 27APR2013	
TOLERANCES UNLESS OTHERWISE SPECIFIED:		APVD: ALEY CAI 27APR2013	NAME: CAGE ASSEMBLY, THRU BEZEL, QSFP, WITH HEAT SINK
0 PLC ±	1 PLC ±0.25	PRODUCT SPEC: 108-2286	SIZE: A1
2 PLC ±0.13	3 PLC ±	APPLICATION SPEC: 114-13217	CAGE CODE: 00779
4 PLC ±	ANGLES ±	WEIGHT: -	DRAWING NO: C=2170536
FINISH		CUSTOMER DRAWING	RESTRICTED TO: -
SCALE 2:1			SHEET 2 OF 4
REV B			

LOC		DIST		REVISIONS			
P	LYR	DESCRIPTION	DATE	OWN	APVD		
-	-	SEE SHEET 1	-	-	-		

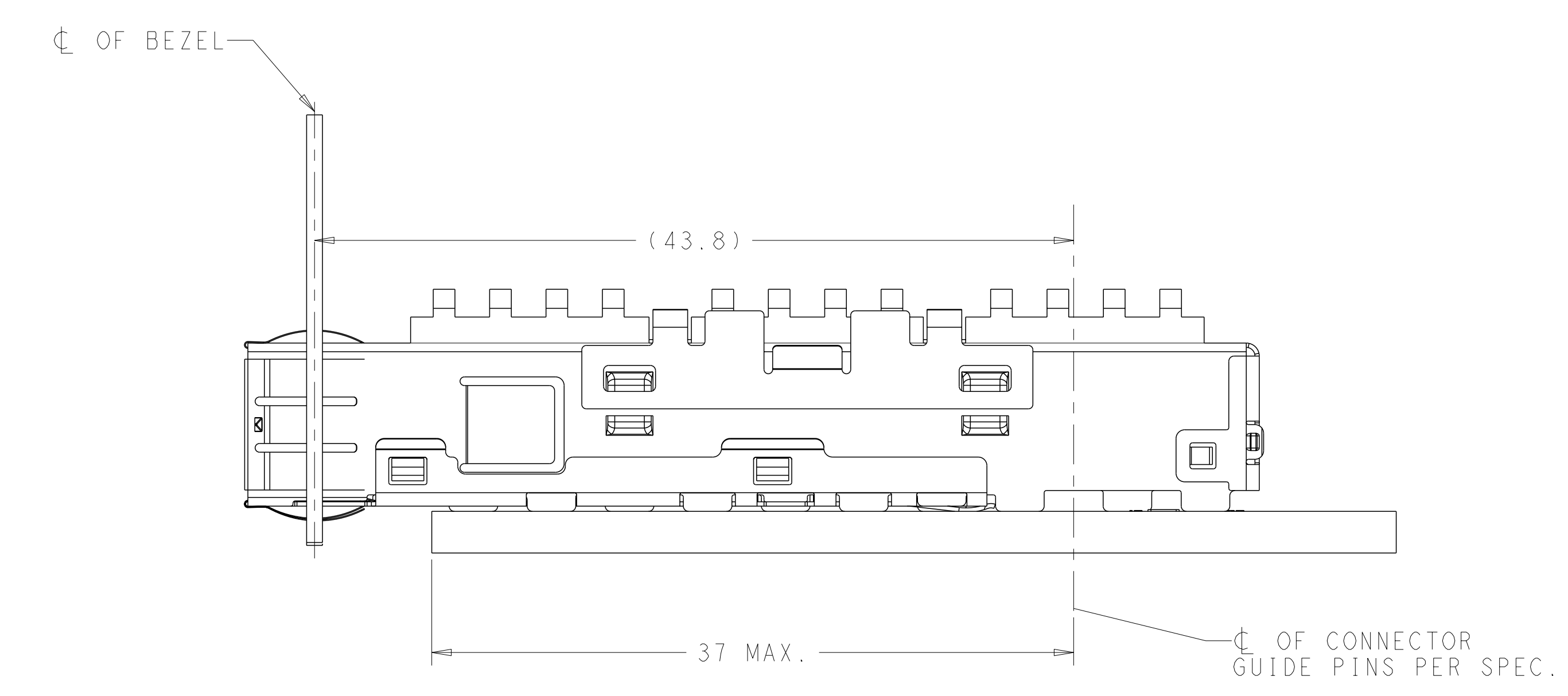
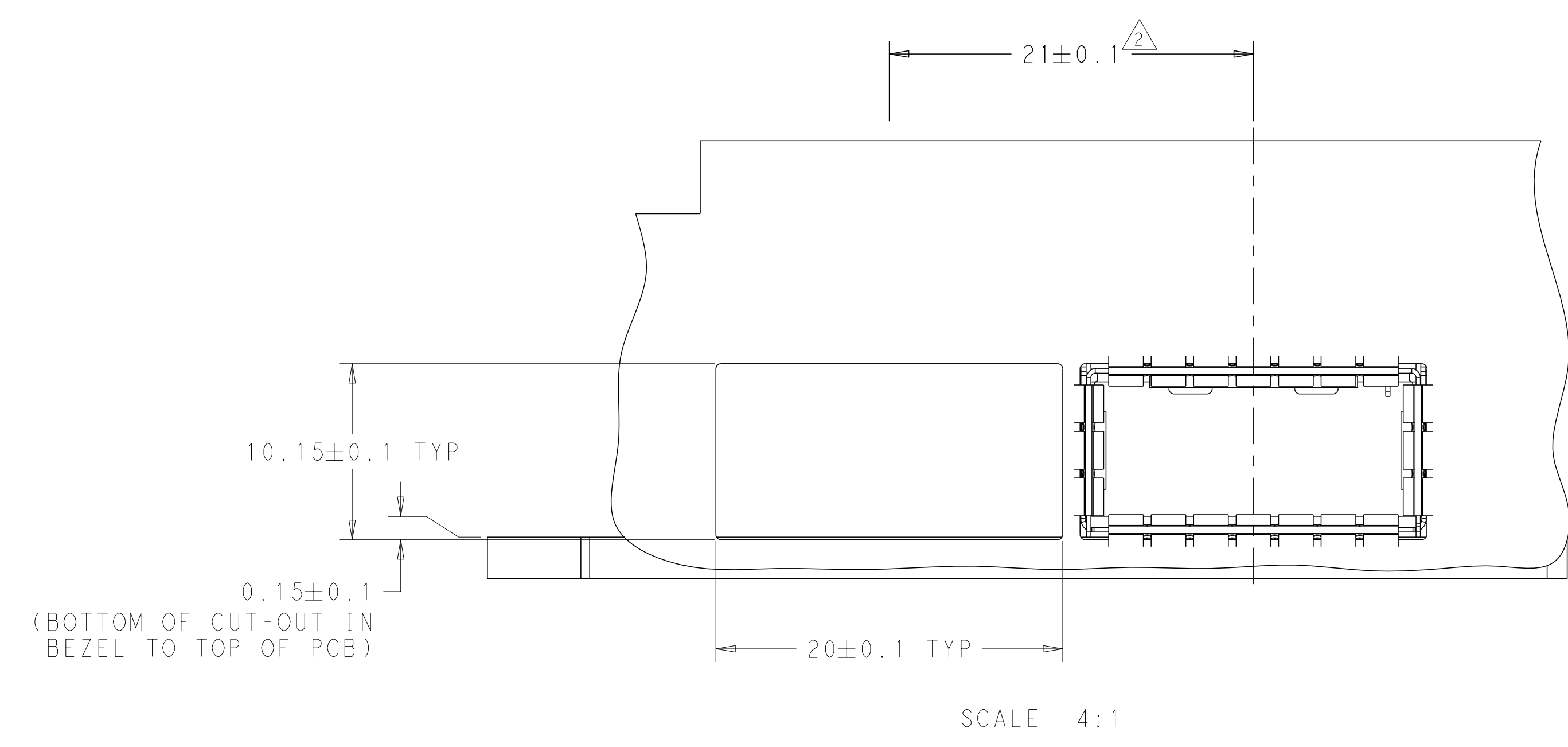

THIS DRAWING IS A CONTROLLED DOCUMENT.		OWN: HANK WU 27APR2013	TE Connectivity
DIMENSIONS: mm		CHK: JASON YANG 27APR2013	
TOLERANCES UNLESS OTHERWISE SPECIFIED:		APVD: AILEY CAI 27APR2013	NAME: CAGE ASSEMBLY, THRU BEZEL, QSFP, WITH HEAT SINK
0 PLC ±	1 PLC ±0.25	PRODUCT SPEC 108-2286	SIZE: A1
2 PLC ±0.13	3 PLC ±	APPLICATION SPEC 114-13217	CAGE CODE: 00779
4 PLC ±	ANGLES ±	WEIGHT: -	DRAWING NO: C=2170536
FINISH ±		MATERIAL: CUSTOMER DRAWING	RESTRICTED TO: -
SCALE: 2:1			SHEET: 3 OF 4
REV: B			

LOC	DIST	REV	DATE	OWN	APVD
-	-	1	-	-	-
SEE SHEET 1					

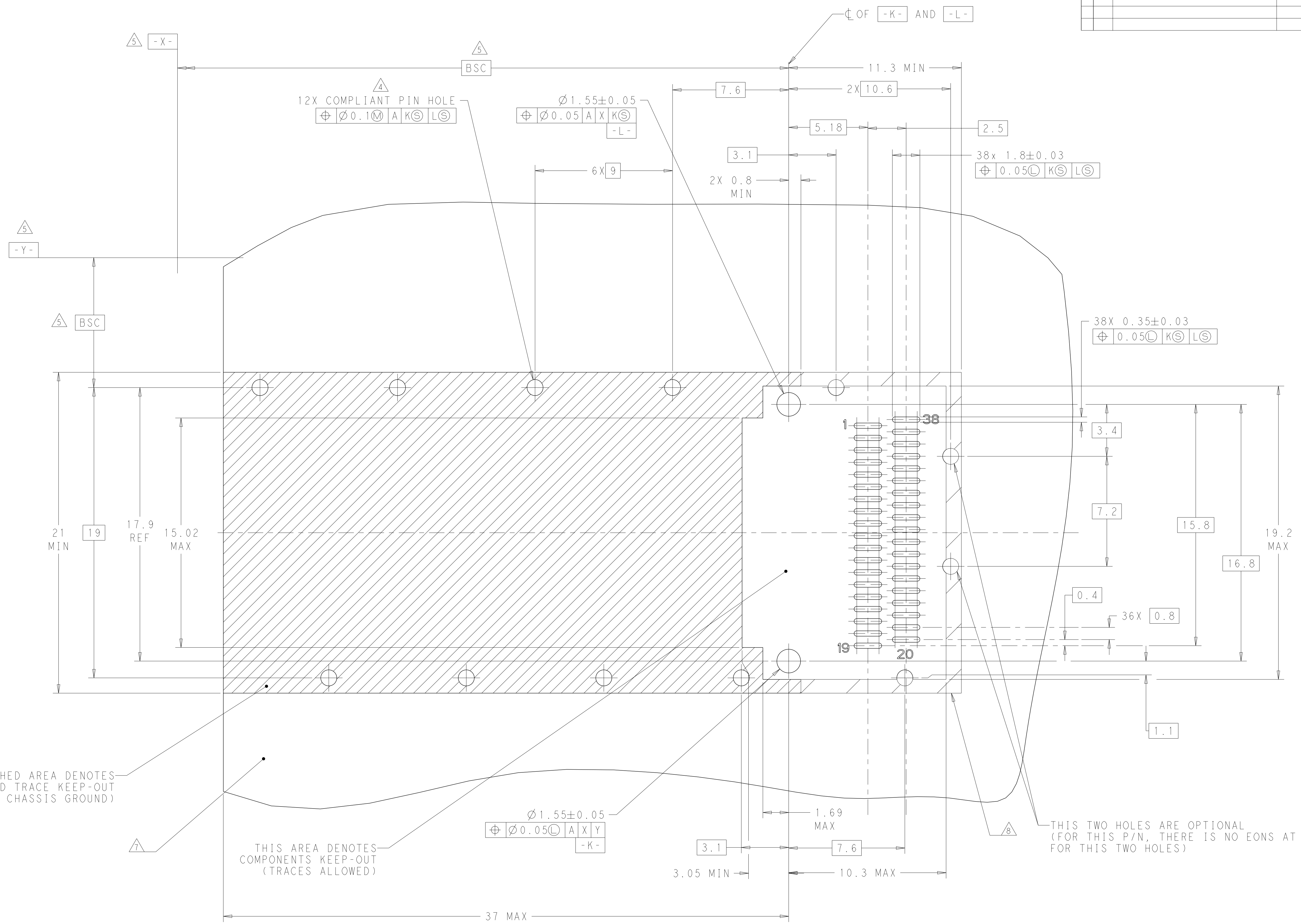

CROSS-HATCHED AREA DENOTES COMPONENT AND TRACE KEEP-OUT (EXCEPT CHASSIS GROUND)

THIS AREA DENOTES COMPONENTS KEEP-OUT (TRACES ALLOWED)

THIS TWO HOLES ARE OPTIONAL (FOR THIS P/N, THERE IS NO EONS AT TAIL FOR THIS TWO HOLES)

Ø1.55±0.05  
Ø0.05 A X Y  
-K-

RECOMMENDED PC BOARD LAYOUT  
SCALE 8:1

THIS DRAWING IS A CONTROLLED DOCUMENT.		OWN: HANK WU 27APR2013	 TE Connectivity
DIMENSIONS: mm		CHK: JASON YANG 27APR2013	
TOLERANCES UNLESS OTHERWISE SPECIFIED:		APVD: ALEY CAI 27APR2013	
0 PLC ± 1 PLC ±0.25 2 PLC ±0.13 3 PLC ± 4 PLC ± ANGLES FINISH ±		NAME: CAGE ASSEMBLY, THRU BEZEL, QSFP, WITH HEAT SINK	
MATERIAL		SIZE: 114-13217	RESTRICTED TO:
		WEIGHT: -	A1 00779 ©=2170536
		CUSTOMER DRAWING	SCALE 2:1 SHEET 4 OF 4 REV B