

LOC		DIST		REVISIONS			
P	LTN	DESCRIPTION	DATE	DMN	APVD		
A		PRODUCTION RELEASE	29FEB2016	JW	SH		

- NOTES: UNLESS OTHERWISE SPECIFIED
- MATERIAL: ALUMINUM.  
FINISH: ELECTROLESS NICKEL.
  - INTERPRET DRAWING PER ASME Y14.5M - 1994.
  - 0.2mm MAX BURR.
  - VARIATION IN PLATING COLOR IS NORMAL AND ALLOWED.
  - RoHS COMPLIANT AND CERTIFIED.

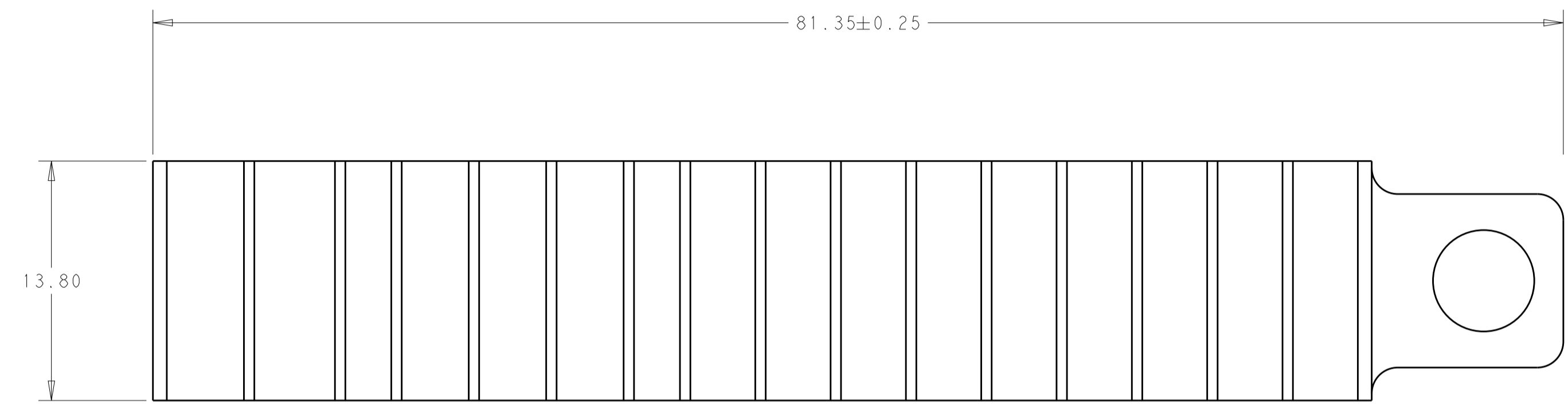

SCALE 4:1

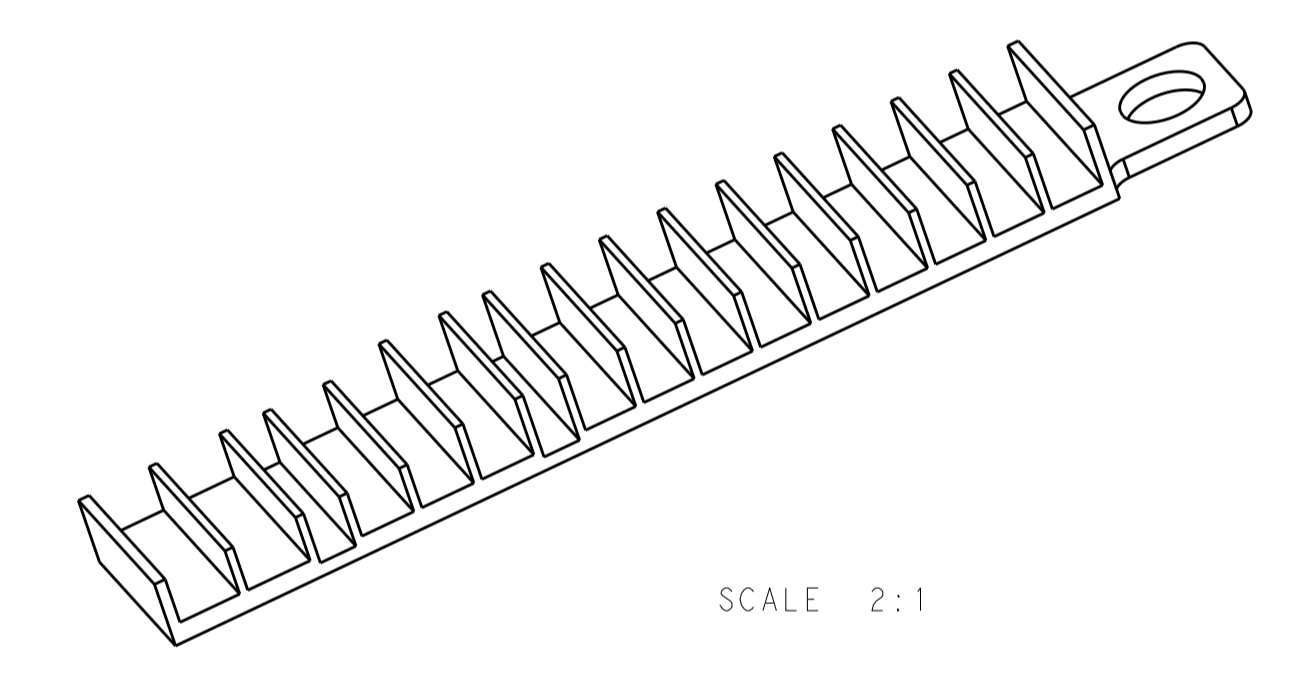
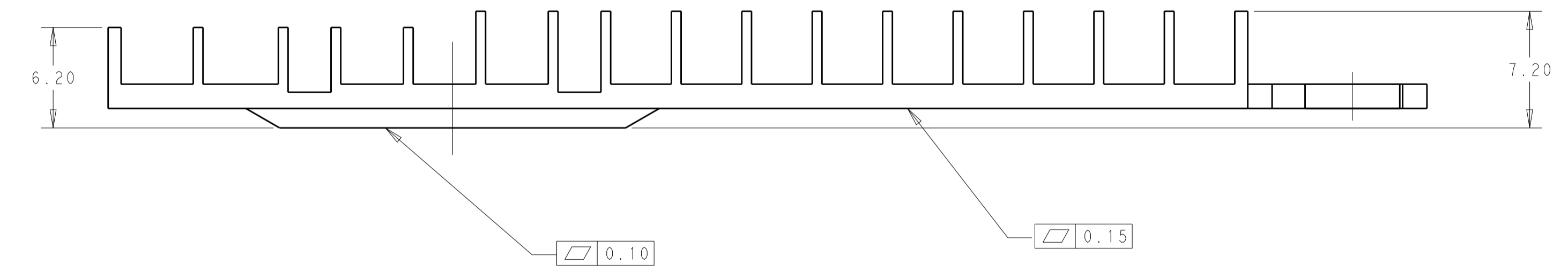
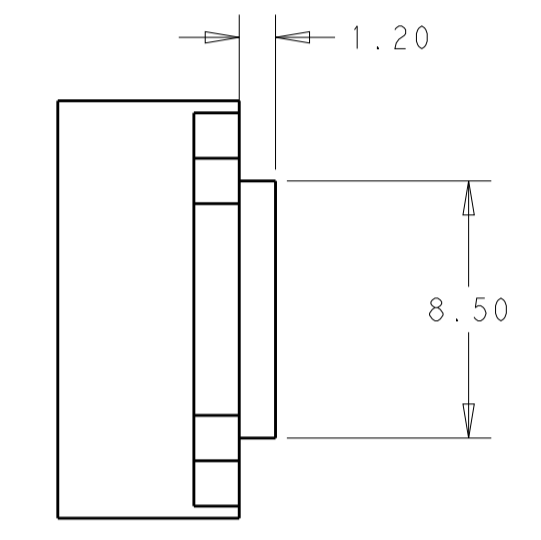

SCALE 2:1

SALE PART		2170262-2
REMARK	FINISH	PART NUMBER

THIS DRAWING IS A CONTROLLED DOCUMENT.		DMN: JEREMY JI 24FEB2012	NAME: SFP+ 1X1 HEATSINK, SPECIAL TYPE	
DIMENSIONS: mm		CHK: ALEX CAI 24FEB2012	SIZE: A1	
TOLERANCES UNLESS OTHERWISE SPECIFIED:		APVD: ALEX CAI 24FEB2012	CAGE CODE: 2170262	
0 PLC ±	1 PLC ±0.5	PRODUCT SPEC	RESTRICTED TO	
2 PLC ±0.5	3 PLC ±0.25	APPLICATION SPEC	-	
4 PLC ±	ANGLES ±	WEIGHT	-	
MATERIAL	FINISH	CUSTOMER DRAWING	SCALE: 1:1	SHEET 1 OF 1