

REVISIONS					
P	LTN	DESCRIPTION	DATE	OWN	APVD
B10		REVISED PER ECO-18-016624	19OCT2018	JMS	JS
B11		REVISED PER ECO-18-017381	02NOV2018	JMS	JS
B12		REVISED PER ECO-20-002333	19FEB2020	JMS	JS
B13		REVISED PER ECN-21-116237	06OCT2021	JMS	JS

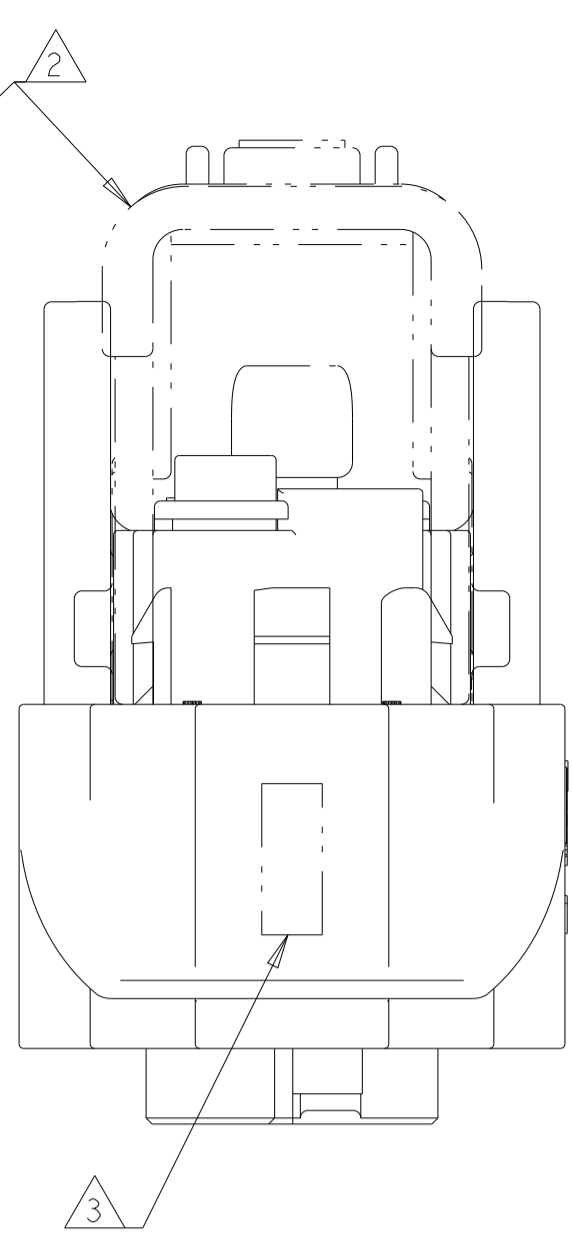

- MATERIAL:**
 HOUSING AND SEAL COVER - PBT, 30% GLASS-FILLED, COLOR: BLACK
 TPA - PBT, 30% GLASS-FILLED, COLOR: NATURAL
 LEVER - PBT, 30% GLASS-FILLED, COLOR: GRAY
 PERIPHERAL SEAL - SILICONE RUBBER, COLOR: GREEN
 MAT SEAL - SILICONE RUBBER, COLOR: LIGHT BLUE
- 2 WIRE DRESS COVER, P/N 2098811-1, SHOWN FOR REFERENCE ONLY AND MUST BE ORDERED SEPARATELY.
 - 3 ASSEMBLY MANUFACTURING DATE CODE AND TE PART NUMBER ARE PERMANENTLY MARKED IN APPROX LOCATION.
 - 4 SEAL PLUGS ARE REMOVED FROM THE APPROPRIATE CIRCUIT CAVITIES IN THE SEAL COVER PER THE PINOUT TABLE ON SHEET 2.
 - 5. CONNECTOR WITH TIN PLATED HARNESS SIDE TERMINALS MUST BE MATED TO SILVER PLATED BLADES IN THE HEADER INTERFACE TO MEET USCAR-2 ELECTRICAL/ENVIRONMENTAL REQUIREMENTS.
 - 6. 2.8mm TERMINALS MUST USE 1.5-2.5mm² WIRE, HAVING 125° C TEMPERATURE RATING AND INSULATION O.D. OF 2.2-3.0mm.
 - 7. USCAR-2 FORCE TO ENGAGE/UNSEAT FROM PRELOCK POSITION SHALL BE 8N MINIMUM AND 75 N MAXIMUM. (SECTION 5.4.3.3A OF USCAR-2, REV. 5)
 - 8. FOR TERMINALS USED, REFER TO INSTRUCTION SHEET.

TPA AND LEVER SHOWN IN PRE-LATCHED AS SHIPPED, POSITION

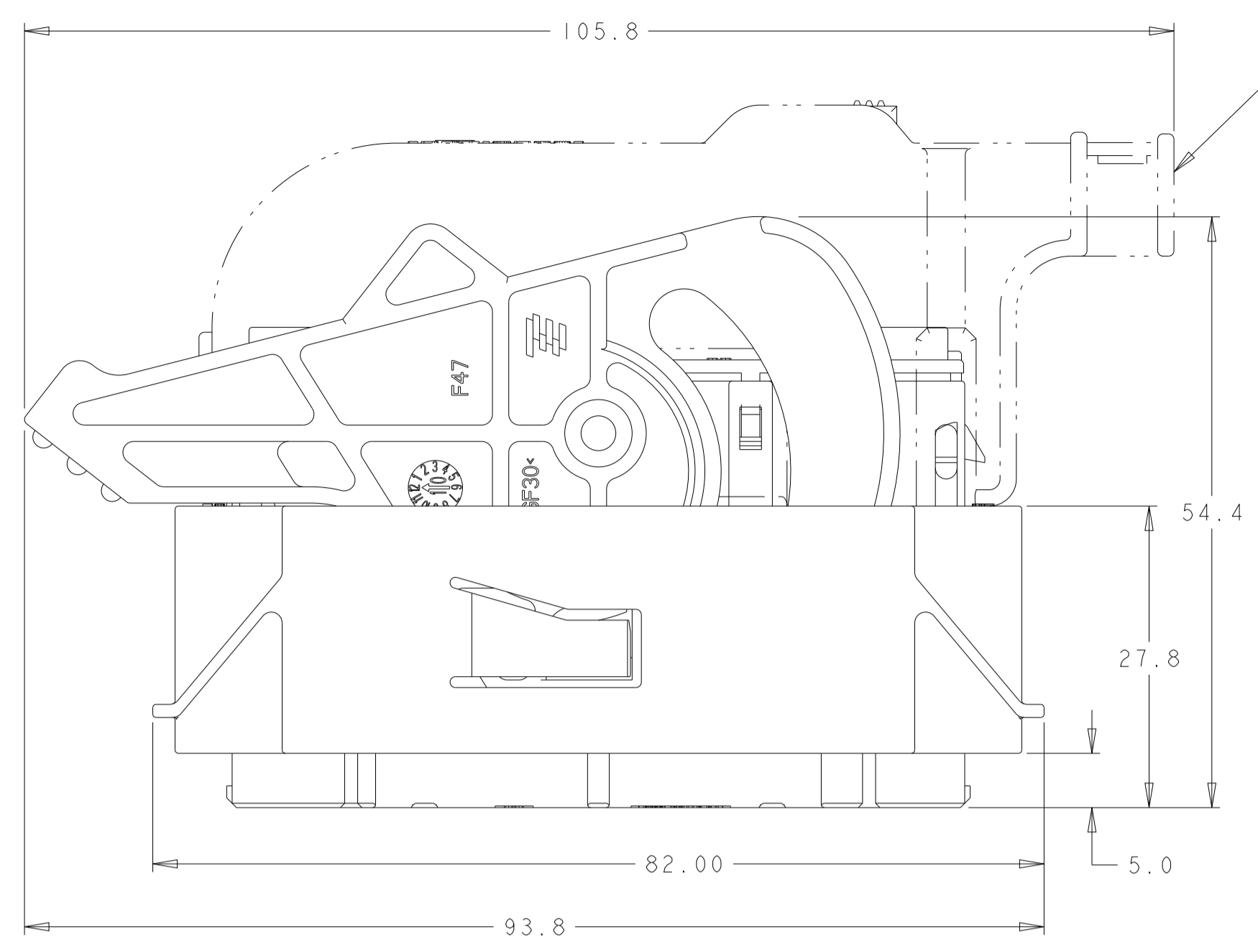
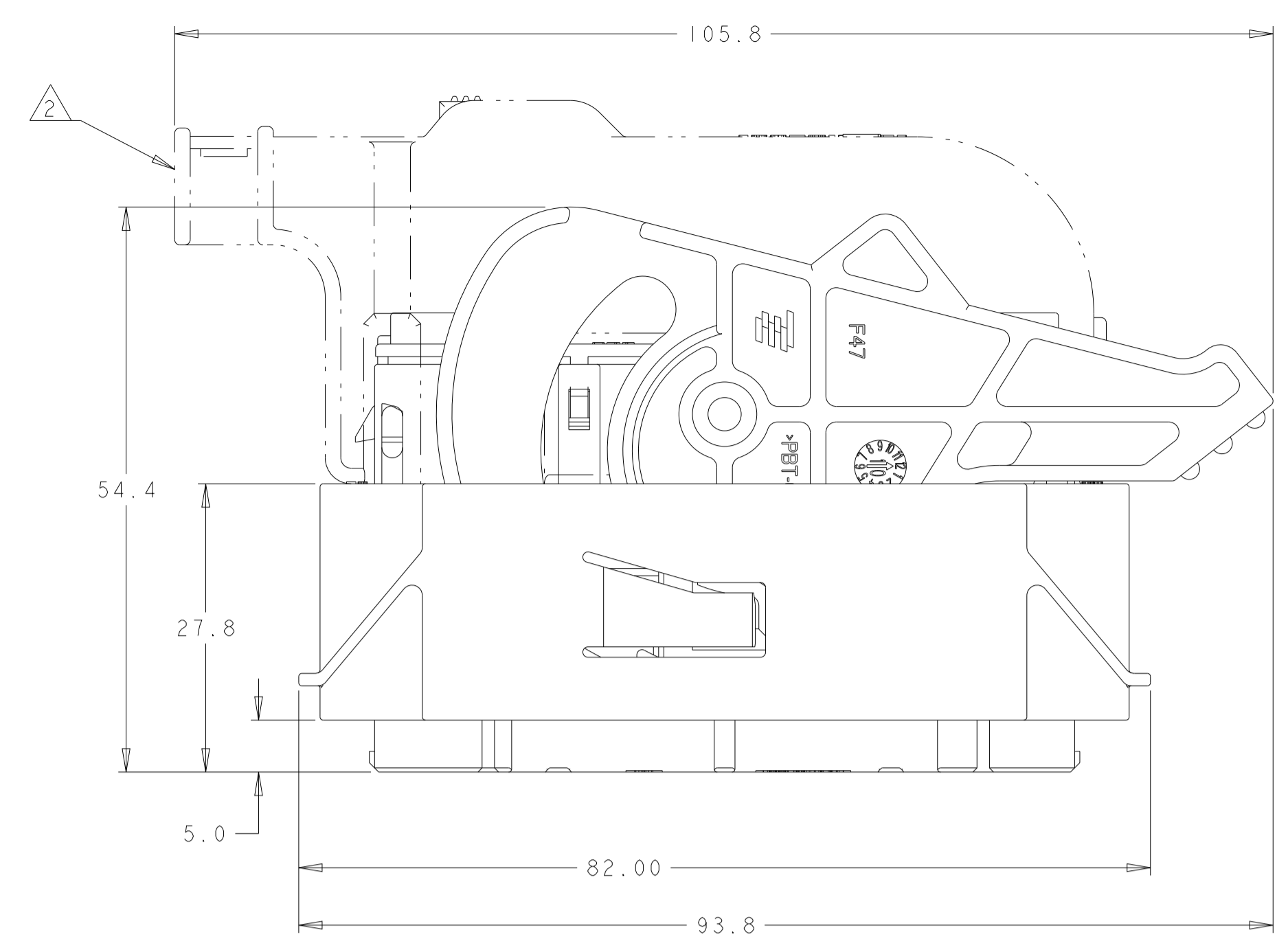
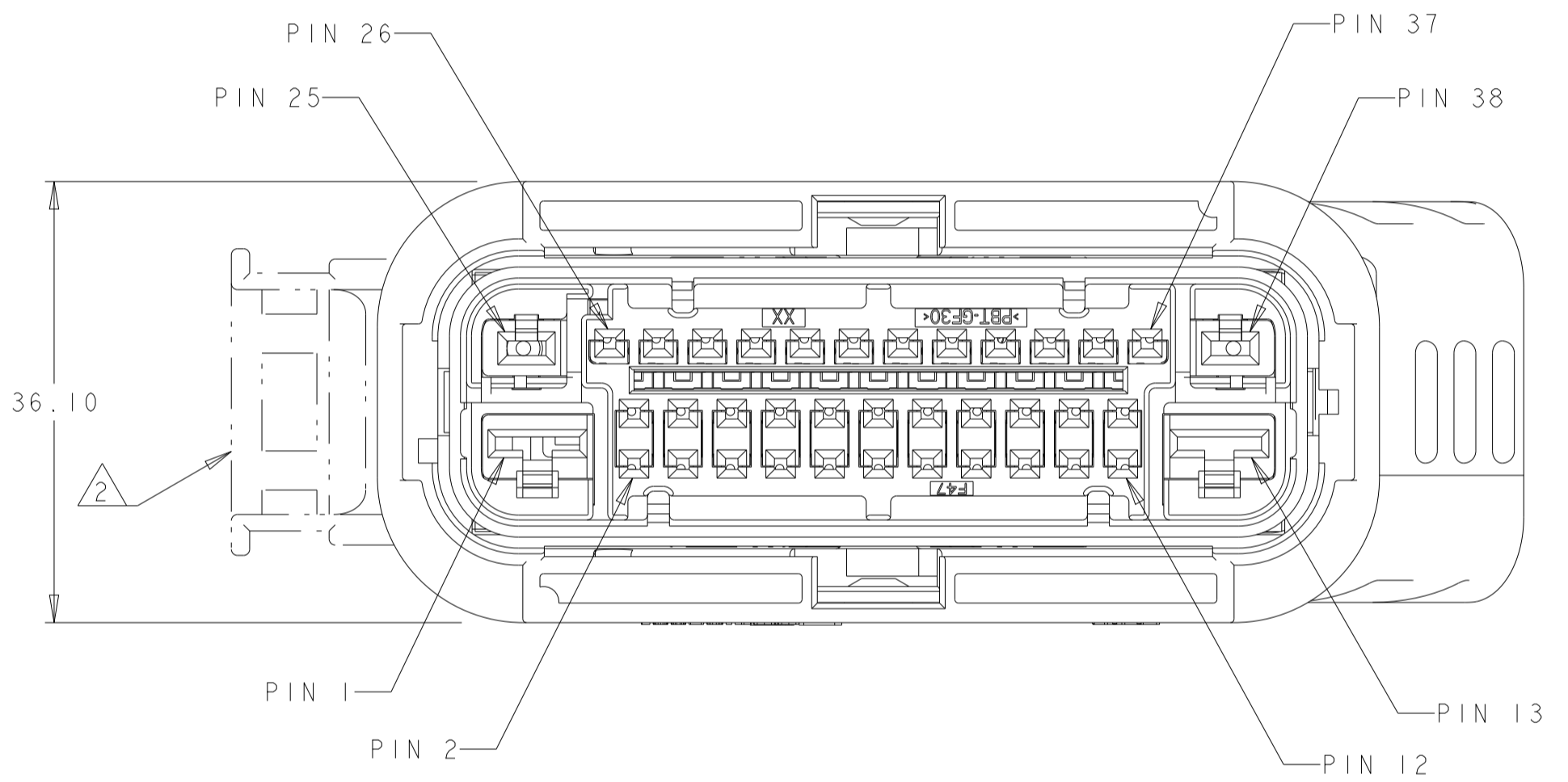

PN 2272223-X SHOWN LEFT CABLE EXIT

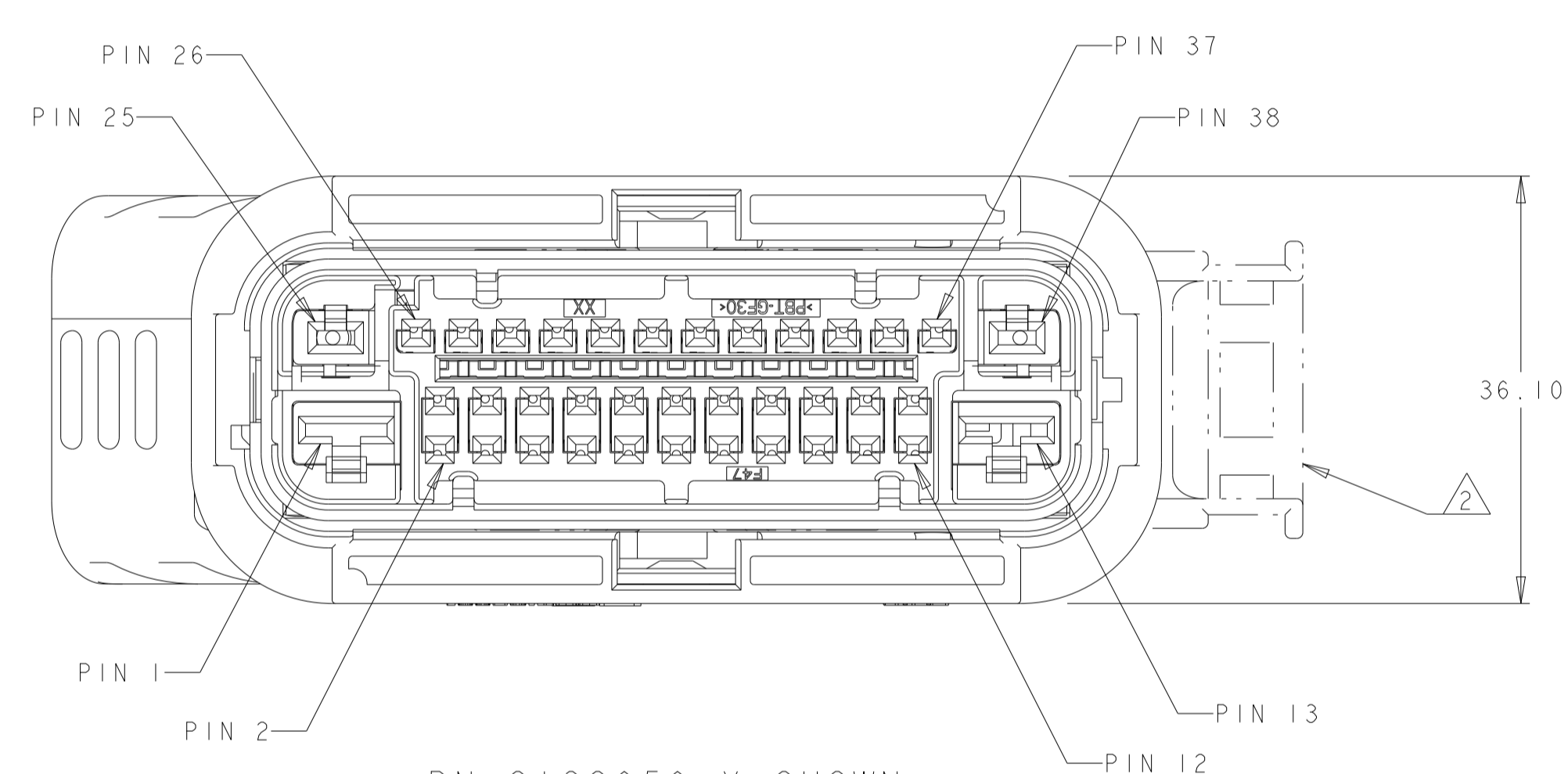

PN 2138659-X SHOWN RIGHT CABLE EXIT

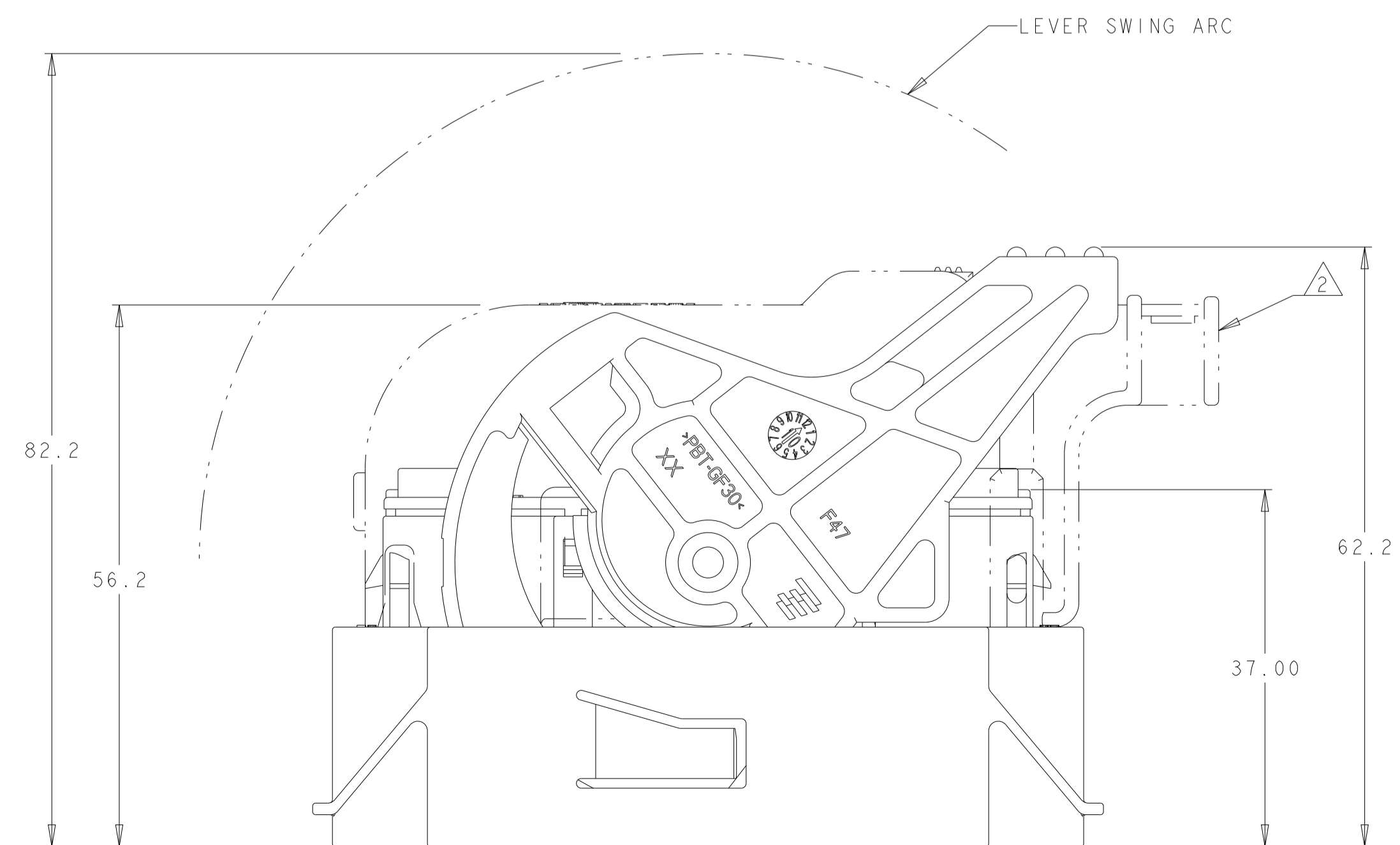
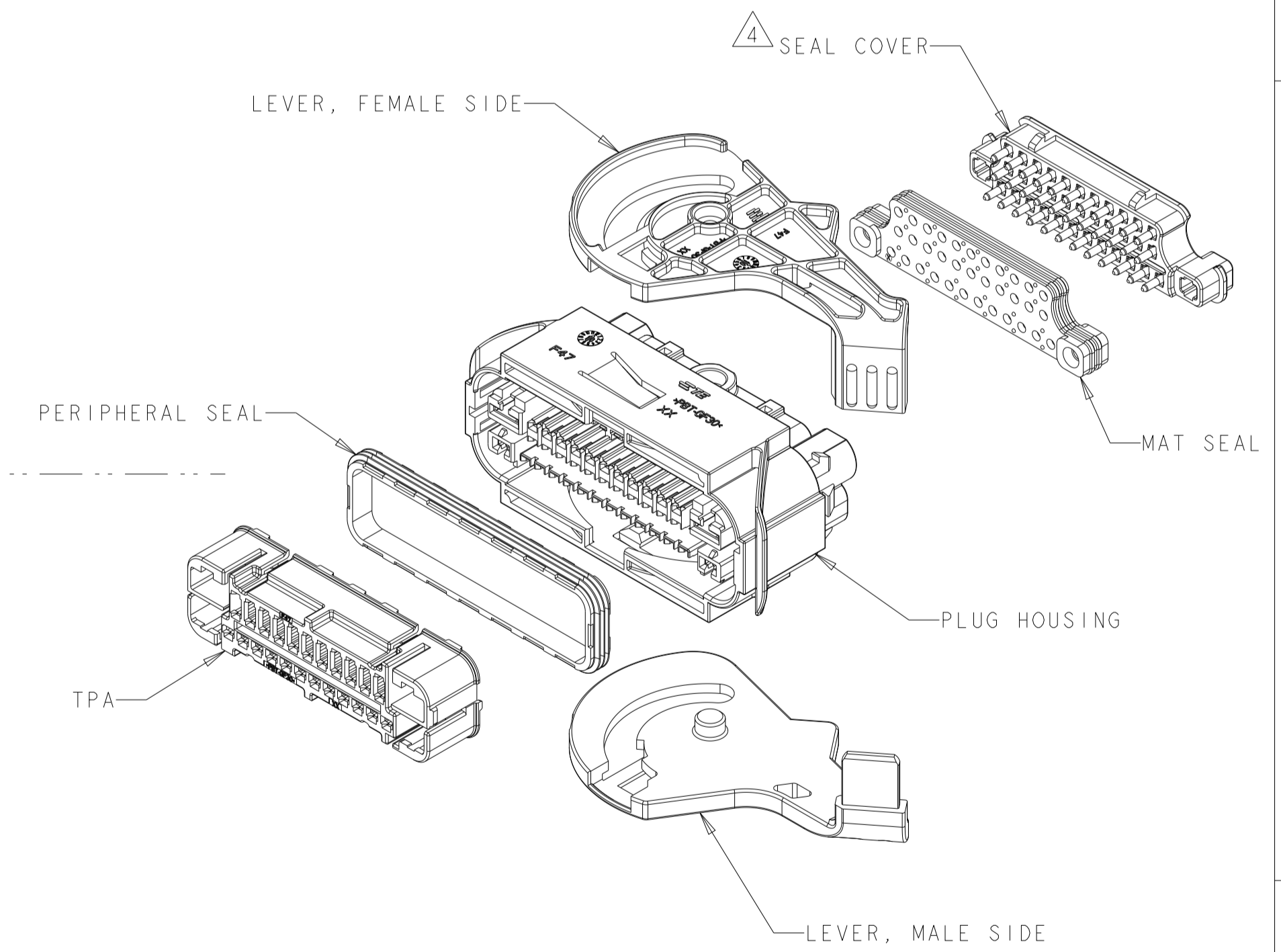

PN 2138659-X SHOWN WITH TPA AND LEVER IN CLOSED, MATED POSITION

SEE SHEET 2 FOR ASSIGNED PART NUMBERS AND BLOCKING PATTERNS

THIS DRAWING IS A CONTROLLED DOCUMENT.		OWN DL DRUMMOND 21JUL2011	
DIMENSIONS: mm		CHK HOY BECK 21JUL2011	
TOLERANCES UNLESS OTHERWISE SPECIFIED:		APVD HOY BECK 21JUL2011	NAME PLUG ASSEMBLY, 38 POSITION, SEALED HYBRID, ABS, EUCON
0 PLC ±	1 PLC ±0.5	PRODUCT SPEC	SIZE CAGE CODE DRAWING NO
2 PLC ±0.20	3 PLC ±	APPLICATION SPEC	RESTRICTED TO
4 PLC ±	ANGLES ±	408-32022	A 00779 C=2138659
MATERIAL	FINISH	WEIGHT	SCALE 2:1 SHEET 1 OF 2 REV B13
CUSTOMER DRAWING			

