

REVISIONS					
P	LTR	DESCRIPTION	DATE	DWN	APVD
4		PRODUCTION ISSUE	31JAN2019	PNT	MT

a) Part as supplied

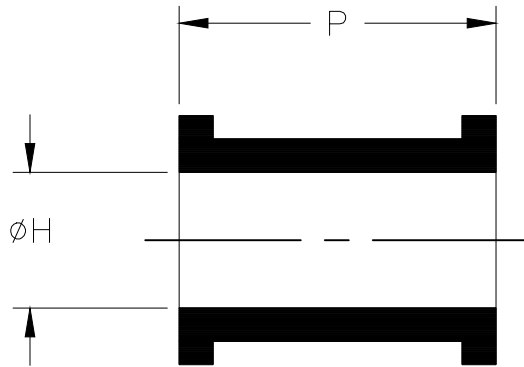

b) Part after unrestricted recovery

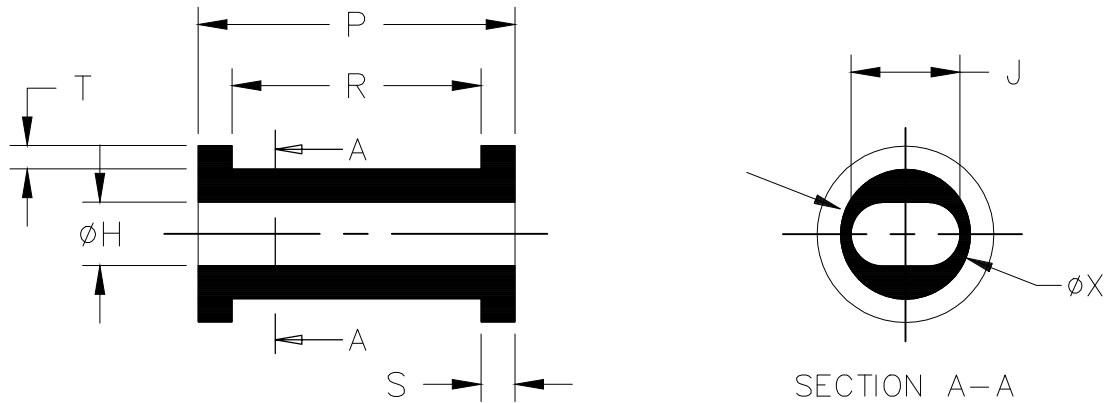

DIMENSIONS <sup>in millimetres</sup>  
[in inches, for reference]

Part No.	H		J		P	R	S	T	X	
	Min	Max	Min	Max	±2	±10%	±10%	±10%	±10%	
	a	b	a	b	a	b	b	b	b	
210W321	12 [.47]	5.9 [.23]	12 [.47]	10.1 [.40]	25 [.98]	31 [1.22]	25 [.98]	3.0 [.12]	2.0 [.08]	12 [.47]
210W331	16 [.63]	7.8 [.31]	16 [.63]	12.2 [.48]	27 [1.06]	32 [1.26]	24 [.94]	4.0 [.16]	2.5 [.10]	14 [.55]

RELEASED FOR PUBLICATION

ALL RIGHTS RESERVED.

THIS DRAWING IS UNPUBLISHED.

TE Connectivity Ltd. COPYRIGHT -

DIMENSIONS: mm [INCHES]	DWN PRAVEEN N T	31JAN2019	MATERIAL SEE SHEET 2	FINISH -
	CHK N NAGAR	31JAN2019	 TE Connectivity Ltd.	
TOLERANCES UNLESS OTHERWISE SPECIFIED:	APVD M TAYLOR	31JAN2019		
0 PLC ± -	PRODUCT SPEC	-	NAME BOBBIN	
1 PLC ± -	-	-	-	
2 PLC ± -	APPLICATION SPEC	-	SIZE	CAGE CODE
3 PLC ± -	-	-	A4	00779
4 PLC ± -	-	-	DRAWING NO	
ANGLES ± -	WEIGHT	-	C-210W3XX-XX-0	
CUSTOMER DRAWING			RESTRICTED TO	-
SCALE DNS			SHEET 1 OF 2	REV 4

REVISIONS					
P	LTR	DESCRIPTION	DATE	DWN	APVD
	-	SEE SHEET 1	-	-	-

## COMPATIBILITY CHART

Material Dash Number	Material Description	RT Spec	Coating Slash No.	Coating S No.
-3	POLYOLEFIN, SEMI-RIGID	RT-301	/42, /86, /180	S1017; S1048; S1030
-4	POLYOLEFIN, FLEXIBLE	RT-1304	/42, /86, /180	S1017; S1048; S1030
-12	FLUOROELASTOMER, FLEXIBLE	RT-1312	N/A	N/A
-25	ELASTOMER, FLUID RESISTANT	RW-2070	/42, /86, /225	S1017; S1048; S1206
-100	POLYOLEFIN, SEMI-FLEXIBLE ZEROHAL	RW-2082	/86; /180	S1048; S1030

## Ordering Information

210W3X1-XX/XX-0

- Color designator
- Adhesive Slash Number (if required see compatibility chart)
- Material Dash Number (see compatibility chart)
- Base Part Number

### NOTES

- As supplied dimensions are for uncoated parts, when coating is added entry diameters will reduce by 1.5mm[.06] Max.

RELEASED FOR PUBLICATION

ALL RIGHTS RESERVED.

© COPYRIGHT - TE Connectivity Ltd.

THIS DRAWING IS UNPUBLISHED.

DIMENSIONS: mm [INCHES]	DWN PRAVEEN N T 31JAN2019	MATERIAL -	FINISH -		
	CHK N NAGAR 31JAN2019	TE Connectivity Ltd.			
TOLERANCES UNLESS OTHERWISE SPECIFIED:  0 PLC ± - 1 PLC ± - 2 PLC ± - 3 PLC ± - 4 PLC ± - ANGLES ± -	APVD M TAYLOR 31JAN2019			NAME BOBBIN	
	PRODUCT SPEC -	SIZE A4	CAGE CODE 00779		
APPLICATION SPEC -		WEIGHT -		CUSTOMER DRAWING	
		SCALE DNS		SHEET 2 OF 2	REV 4