

THIS DRAWING IS UNPUBLISHED. RELEASED FOR PUBLICATION 20  
 © COPYRIGHT 20 BY - ALL RIGHTS RESERVED.

LOC		DIST		REVISIONS			
P	LTR	DESCRIPTION	DATE	DWN	APVD		
	B	REVISE PER ECO-11-019143	21/SEP/11	ECC	PJB		

- 1 MATERIALS AND FINISH:
  - HOUSING: PC, COLOR: BLACK
  - SEAL: SILICONE RUBBER, COLOR: BLUE
  - CONTACTS: COPPER ALLOY  
FINISH: TIN IN CONTACT AREA OVER NICKEL UNDERPLATE
  - WIRE: 22 AWG, STRANDED, UL 1007 STYLE
- 2. MUST COMPLY WITH DIRECTIVE 2002/95/EC (ROHS)
- 3 REFERENCE CHART FOR SPECIFIC WIRE COLOR/POSITION

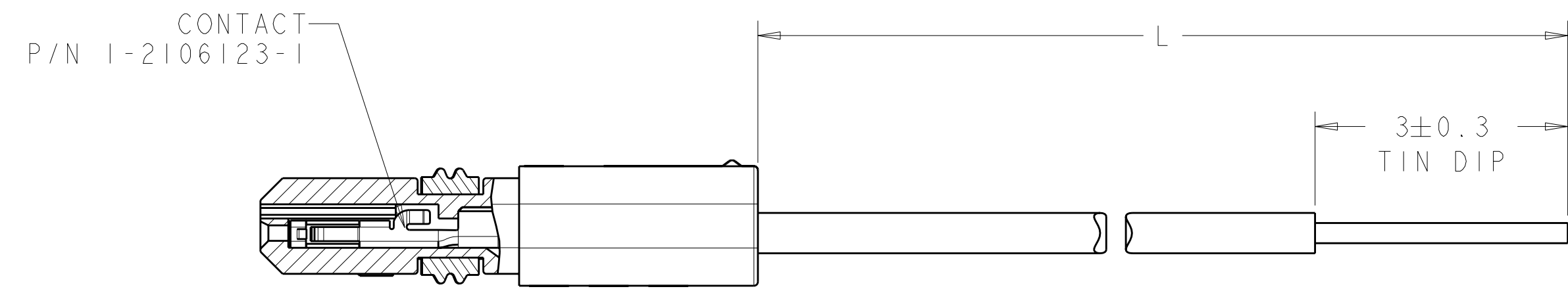
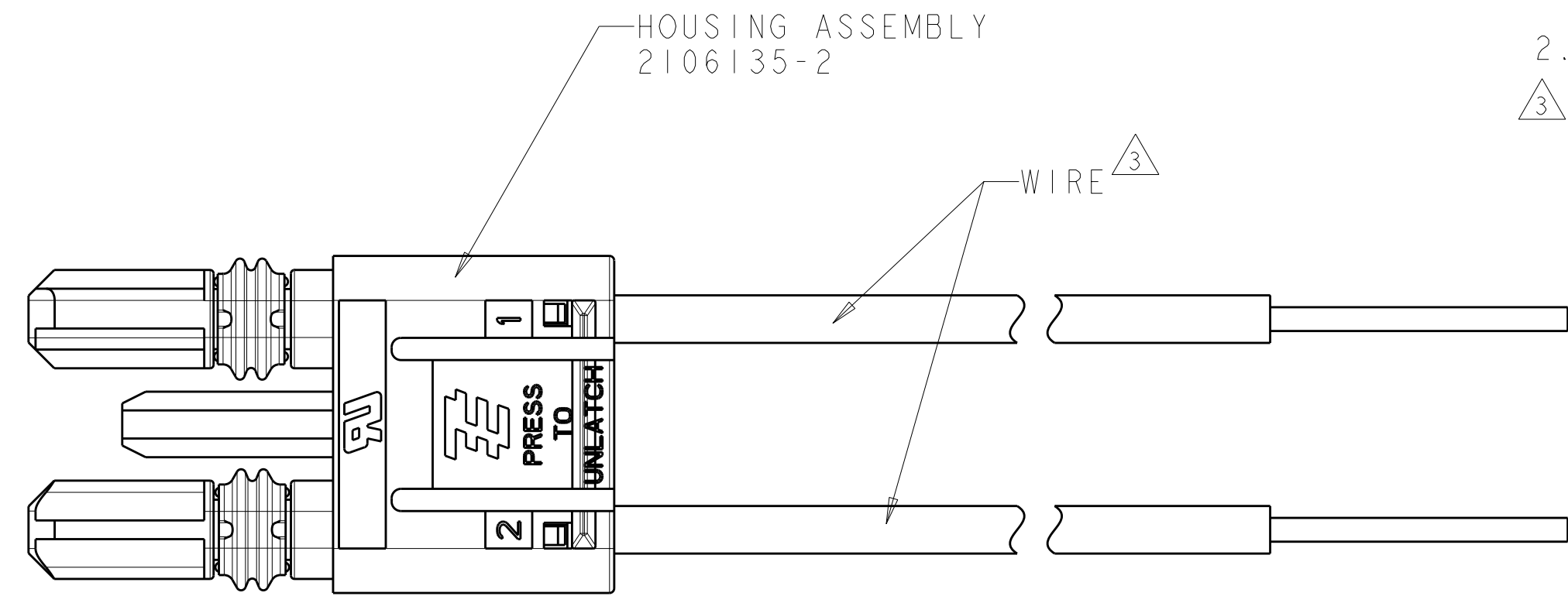

	WIRE COLOR 3	WIRE COLOR 3
2	BLACK	BLACK
1	RED	RED
POSN	-1	-2

525.0+/-5.0	2	2106841-2
209.0+/-4.0	2	2106841-1
LENGTH	POSN	TE P/N

THIS DRAWING IS A CONTROLLED DOCUMENT.		DWN 29OCT2009 WM VAN SCYOC	<b>STE</b> TE Connectivity	
		CHK 29OCT2009 M. MOSTOLLER		
DIMENSIONS: mm		TOLERANCES UNLESS OTHERWISE SPECIFIED:		NAME CABLE ASSEMBLY, PLUG, SLIMSEAL SSL CONNECTOR
		0 PLC ±-	PRODUCT SPEC	SIZE
		1 PLC ±0.2	108-2391	CAGE CODE
MATERIAL		2 PLC ±-	APPLICATION SPEC	DRAWING NO
		3 PLC ±-	114-13261	A200779C-2106841
		4 PLC ±-	WEIGHT	RESTRICTED TO
		ANGLES ±-	-	-
		FINISH ±-	CUSTOMER DRAWING	
		SCALE 4:1		SHEET 1 OF 1