

REVISIONS					
P	LTR	DESCRIPTION	DATE	DWN	APVD
A		Go to production	01SEP2022	ED	WH

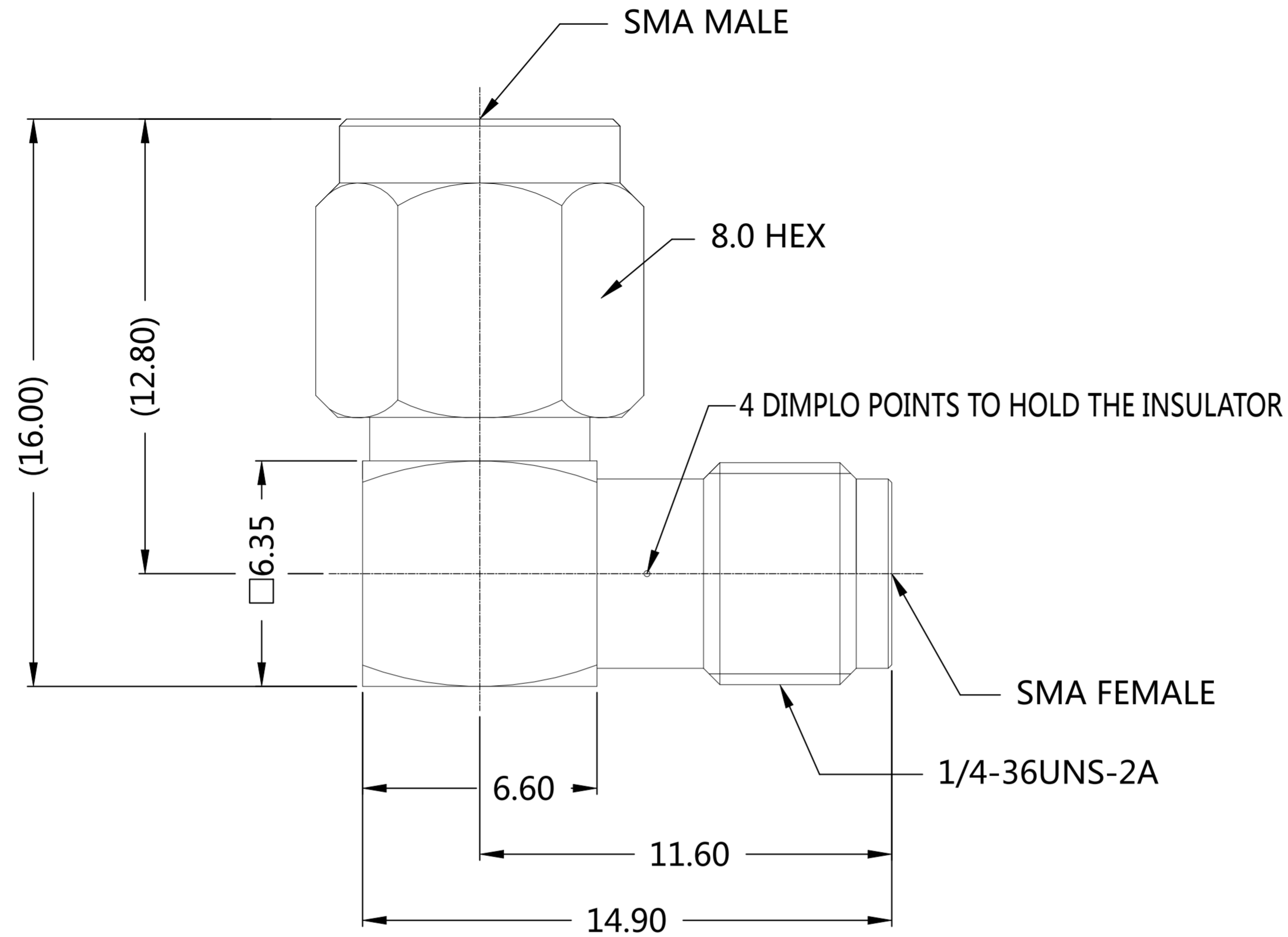

NOTES:

- 1 PACK IN ACCORDANCE WITH TE SPEC 107-3275;
- 2 ALL DIMENSIONS ARE NOMINAL FOR REFERENCE ONLY UNLESS OTHERWISE STATED.

ELECTRICAL	MECHANICAL	ENVIRONMENTAL
Impedance (Ohm) _____50	Interface Dimension MIL-STD-348B Fig. _____310-2	TEMPERATURE RANGE _____ -55' - +125'
Frequency Range (GHz) _____DC to 18GHz	Recommended Coupling Torque _____7 to 10 In-Lbs	THERMAL SHOCK _____MIL-STD-202, METH.107, COND.B
Voltage Rating (Peak) _____@ Sea Level 335 V RMS	Force to Engage and Disengage (In/lbs) _____2.0 MAX	CORROSION _____MIL-STD-202, METH.101, COND.B
Insulation Resistance (MIN.) _____5000 M ohms	Center Contact Captivation Axial (Lbs) _____>6 LBS Radial (In/Oz) _____N/A	VIBRATION _____MIL-STD-202, METH.204, COND.D
Contact Resistance (Milliohms MAX) Center Contact _____3.0 Outer Contact _____2.0	Cable Retention Axial (Lbs) _____N/A	SHOCK _____MIL-STD-202, METH.213, COND.I
Dielectric Withstand Voltage: _____750 V RMS Max	Mating cycles _____500 cycles	MOISTURE RESISTANCE _____MIL-STD-202, METH.106.
Insertion Loss : _____0.1SQRT(FGHz) dB		ROHS _____COMPLIANT
VSWR: _____1.30 MAX(DC-18GHz)		
RF leakage: _____N/A		
3rd Intermodulation: _____N/A		

QUANTITY PER ASSY	DESCRIPTION	MATERIAL	ITEM
1	/	PTFE	INSULATOR 3
1	GOLD 50u"/NICKEL/COPPER	BERYLLIUM COPPER	CENTER CONTACT 2
1	GOLD 1u"/NICKEL/COPPER	CU ALLOY	BODY 1
2081367-1	PLATING	MATERIAL	DESCRIPTION

THIS DRAWING IS A CONTROLLED DOCUMENT.

DWN	ED	12AUG2022
CHK	RZ	12AUG2022
APVD	WH	12AUG2022
PRODUCT SPEC		
APPLICATION SPEC		

NAME: SMA ADAPTER,18GHz, MALE TO FEMALE,RIGHT ANGLE

SIZE	A2	CAGE CODE	00779	DRAWING NO	C=2081367	RESTRICTED TO	
WEIGHT	0	SCALE	8:1	SHEET	1 of 1	REV	A

CUSTOMER DRAWING