

LOC	DIST	REVISIONS					
BD	39	P	LTR	DESCRIPTION	DATE	DWN	APVD
		H1		ECO-07-006181	15JUN07	JDP	CWR

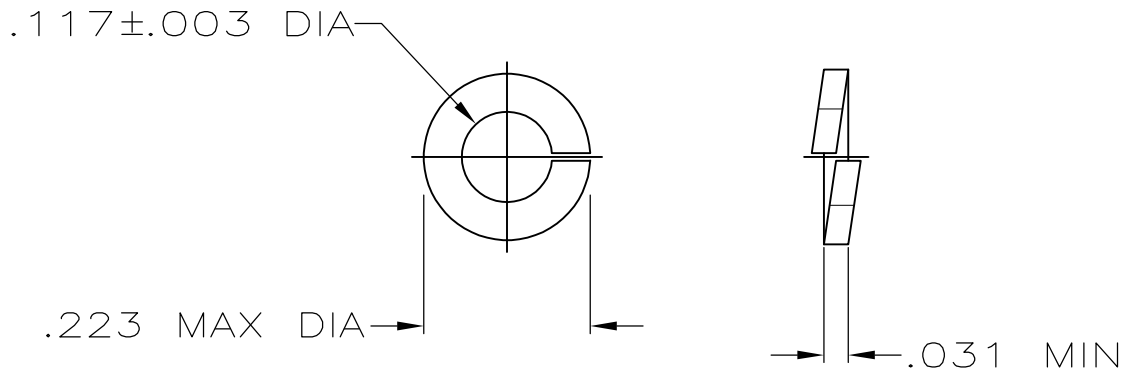

- 1 ZINC PLATED PER ASTM B633, TYPE II, CLASS SC1, (.000197-.000400), YELLOW CHROMATE.
- 2 ZINC PLATED PER ASTM B633, TYPE III, CLASS SC1, (.000197-.000400), CLEAR CHROMATE.
- 3 .000100 MIN TIN PER MIL-T-10727 OVER .000050 MIN COPPER PER MIL-C-14550.

	3	207883-5
OBSOLETE	2	207883-3
OBSOLETE	1	207883-2
	FINISH	PART NUMBER

THIS DRAWING IS UNPUBLISHED. ALL RIGHTS RESERVED. BY TYCO ELECTRONICS CORPORATION. © COPYRIGHT -

DIMENSIONS: INCHES	DWN	C.RICHARD	6-6-88	MATERIAL	COLD ROLLED	FINISH	SEE TABLE
	CHK	W.LENKER	6-15-88	Tyco Electronics Corporation Harrisburg, PA 17105-3608			
TOLERANCES- UNLESS OTHERWISE SPECIFIED:	APVD	6-16-88	-				
	PRODUCT SPEC	R.WHYNE	-	SIZE	CAGE CODE	DRAWING NO	RESTRICTED TO
	APPLICATION SPEC	V.KUMAR	-	A4	00779	C-207883	-
0 PLC ± -	1 PLC ± -	2 PLC ± -	3 PLC ± -	4 PLC ± -	ANGLES ± -	WEIGHT	-
				CUSTOMER DRAWING			
				SCALE	4:1	SHEET	1 OF 1
				REV H1			