

REVISIONS				
P	LTM	DESCRIPTION	DATE	APVD
B		ECR-14-004845	9APR2014	GG RK

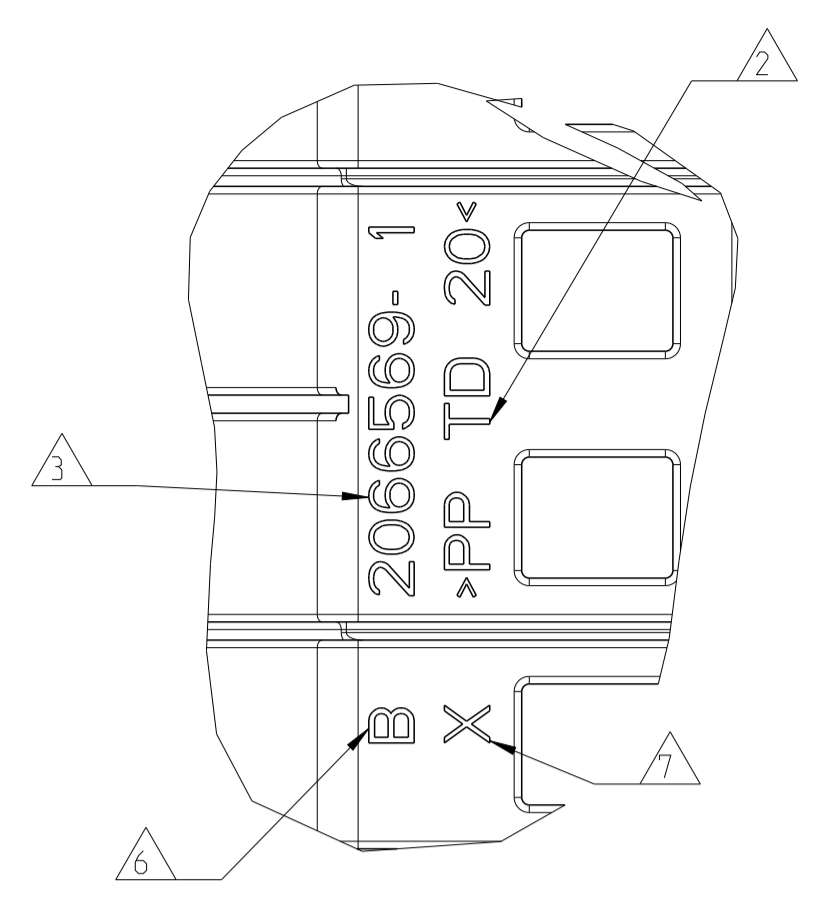

DETAIL B
2:1

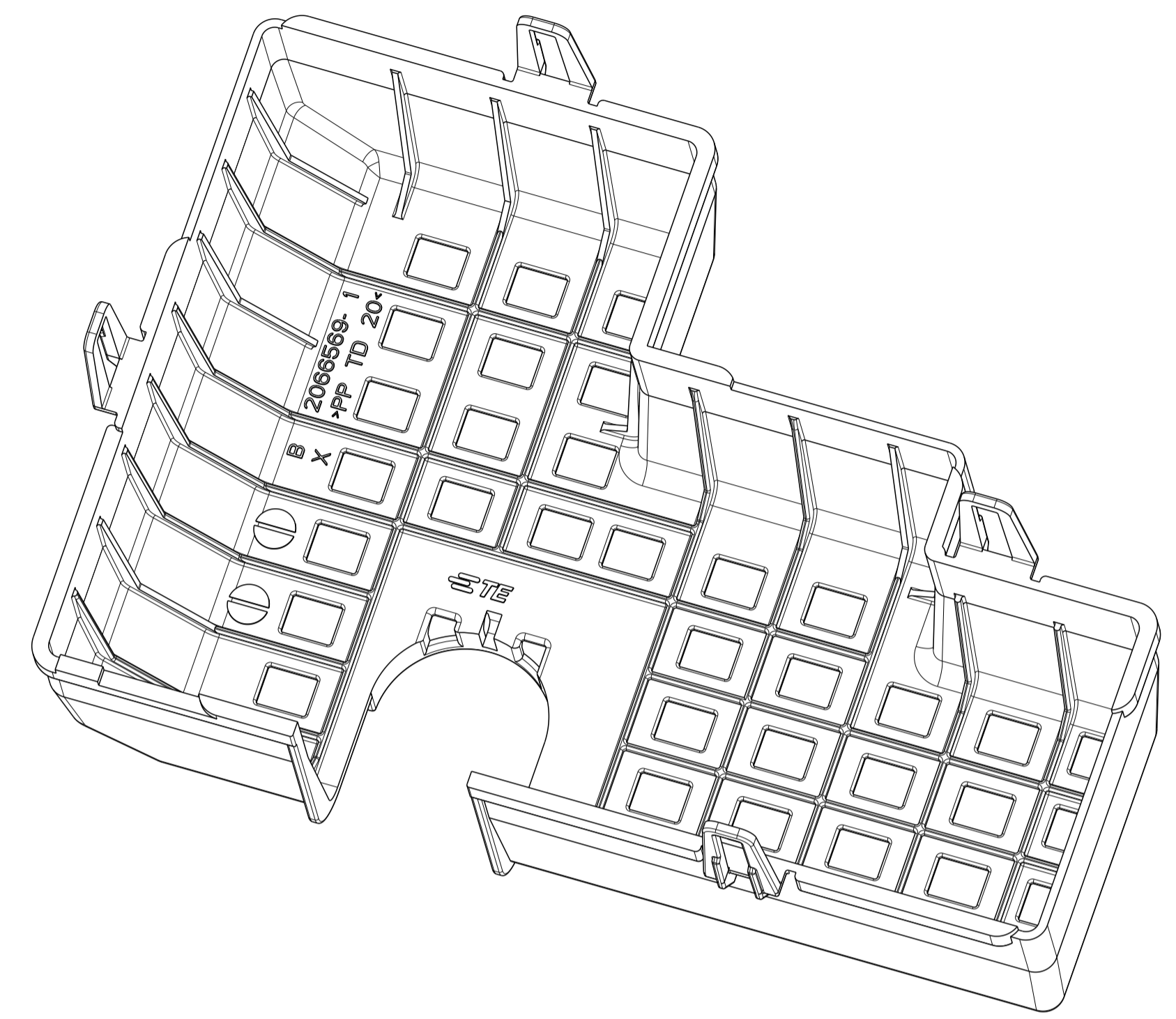
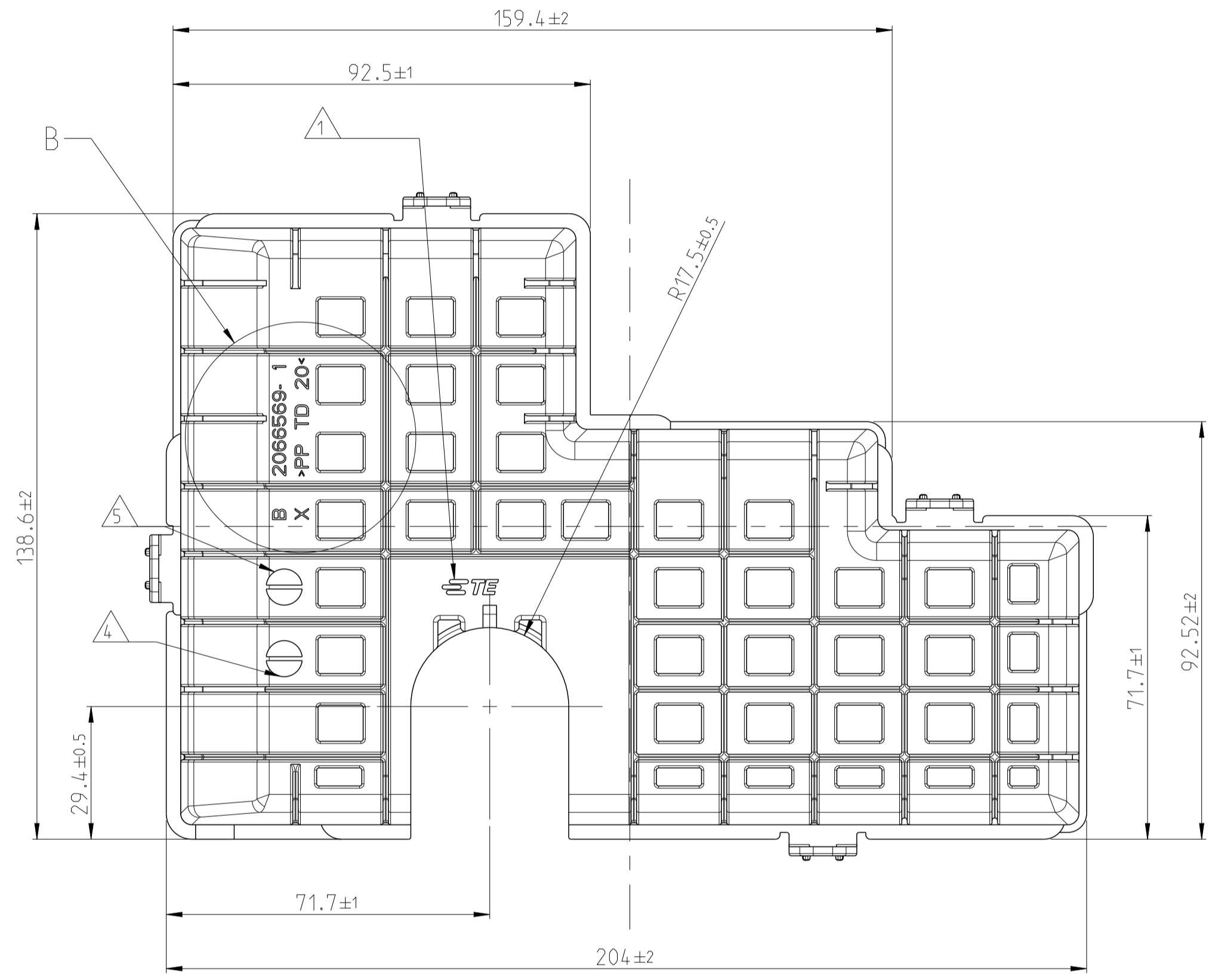
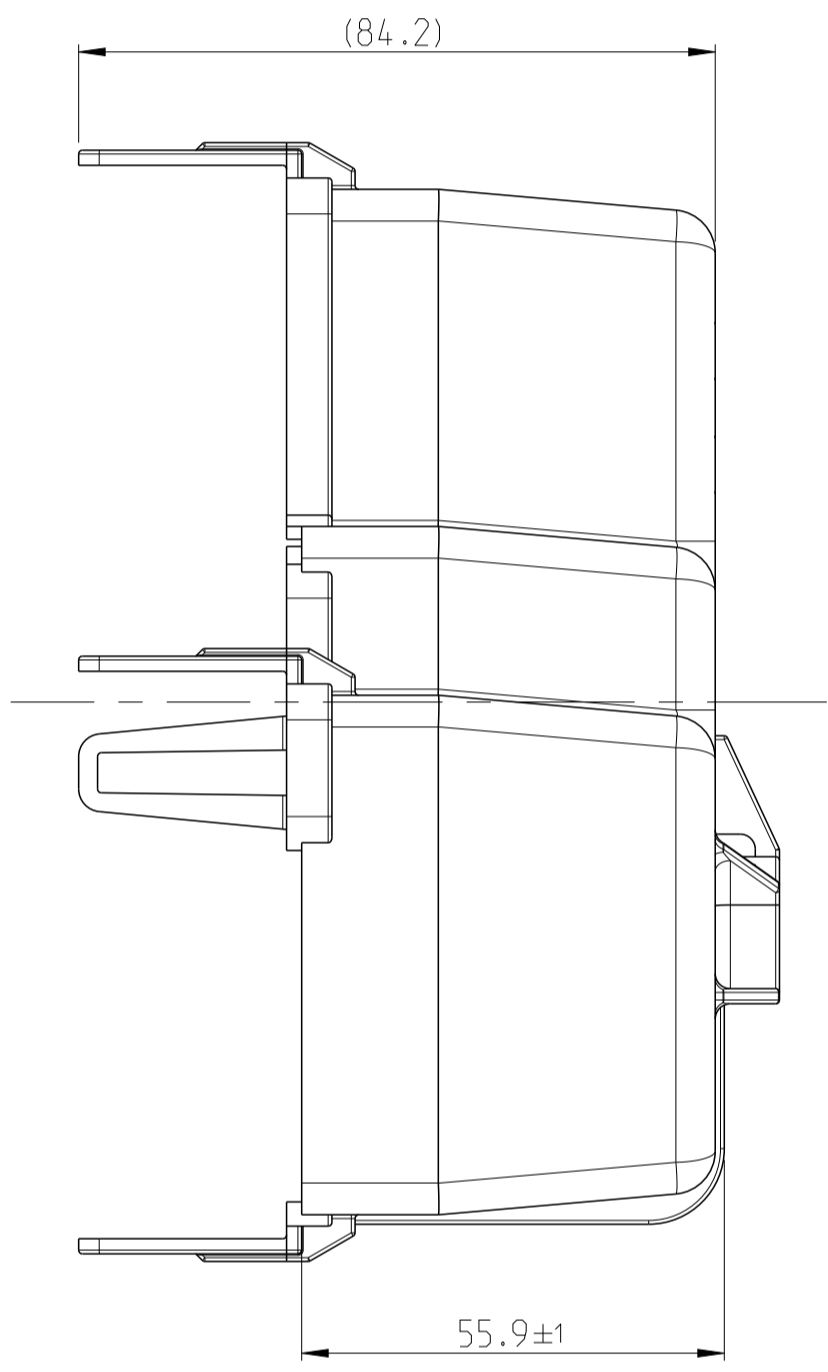

NOTES :-

- 1. TE LOGO
- 2. MATERIAL IDENTIFICATION.
- 3. TE PART NO.
- 4. PRODUCTION MONTH CODE.
- 5. PRODUCTION YEAR CODE.
- 6. PART REVISION.
- 7. TOOL CAVITY MARKING.
- 8. 15% MAX PERMITTED REGARDING MATERIAL PROCESSED IN CLOSED LOOP.
- 9. QIP DIMENSION.

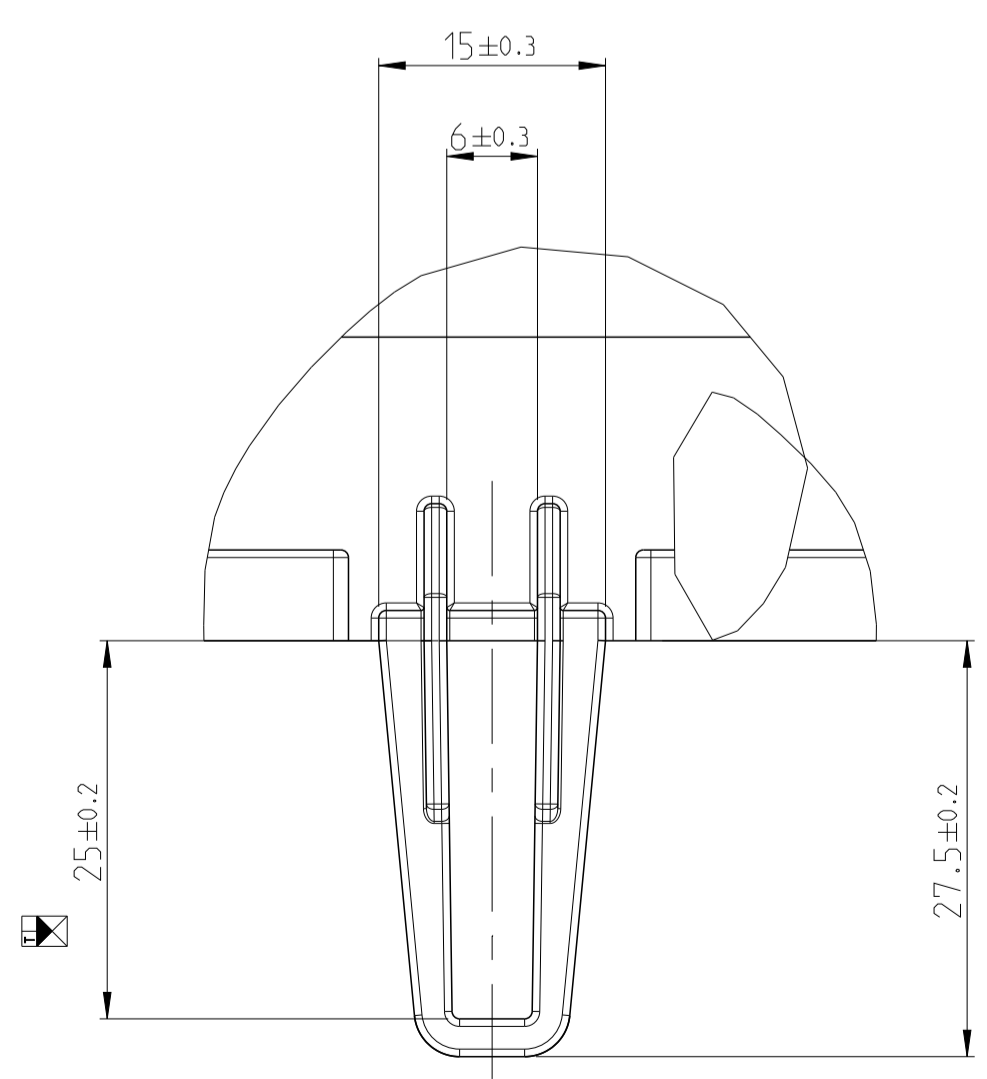

DETAIL A
(4 PLACES) 2:1

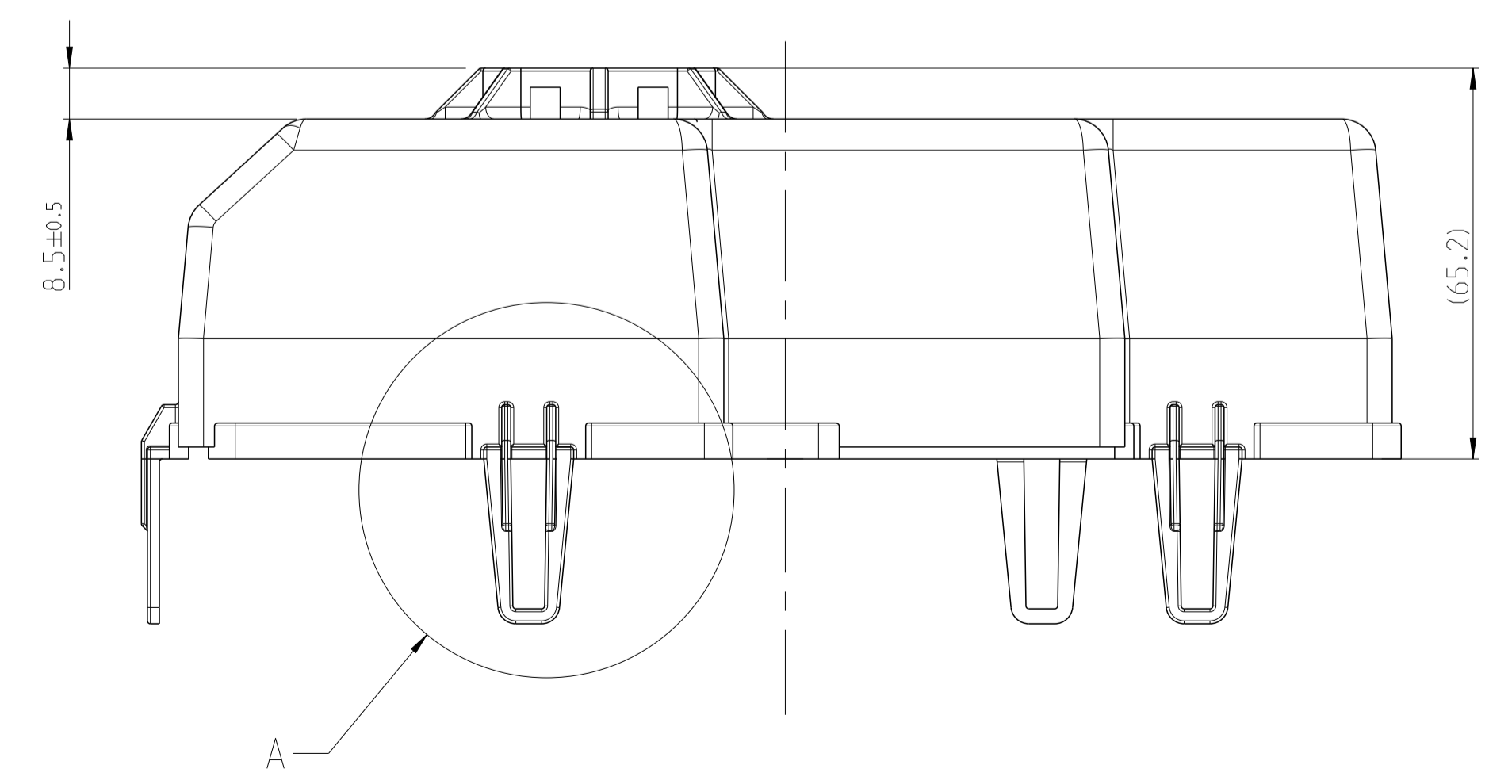

2066569-1	B	BOTTOM COVER, S101.ENGINE COMPT FRB	PP TD 20%	BLACK	1																					
PART NO	REV	DESCRIPTION	MATERIAL	COLOR	ITEM NO																					
THIS DRAWING IS A CONTROLLED DOCUMENT.		OWN: GEETA G 09APR2014	TE Connectivity																							
DIMENSIONS: mm		CHK: RAJESH K 09APR2014																								
TOLERANCES UNLESS OTHERWISE SPECIFIED:		APVD: RAJESH K 09APR2014																								
<table border="1"> <tr><td>7</td><td>PLC</td><td>±</td></tr> <tr><td>6</td><td>PLC</td><td>±</td></tr> <tr><td>5</td><td>PLC</td><td>±</td></tr> <tr><td>4</td><td>PLC</td><td>±</td></tr> <tr><td>3</td><td>PLC</td><td>±</td></tr> <tr><td>2</td><td>PLC</td><td>±</td></tr> <tr><td>1</td><td>PLC</td><td>±</td></tr> <tr><td>0</td><td>PLC</td><td>±</td></tr> </table>		7				PLC	±	6	PLC	±	5	PLC	±	4	PLC	±	3	PLC	±	2	PLC	±	1	PLC	±	0
7	PLC	±																								
6	PLC	±																								
5	PLC	±																								
4	PLC	±																								
3	PLC	±																								
2	PLC	±																								
1	PLC	±																								
0	PLC	±																								
MATERIAL: SEE TABLE	FINISH: -	WEIGHT: 98.5 gms	SIZE: A1	CAGE CODE: C=2066569	RESTRICTED TO: -																					
Customer Drawing		SCALE: 1:1	SHEET: 1 OF 1	REV: B																						