

THIS DRAWING IS UNPUBLISHED. RELEASED FOR PUBLICATION 20
 © COPYRIGHT 20 BY - ALL RIGHTS RESERVED.

REVISIONS					
P	LTR	DESCRIPTION	DATE	DWN	APVD
A		RELEASED	16MAR09	NZ	KD
A1		ECR-20-006758	11MAY20	S.C	I.Y
A2		ECR-21-004733	28MAY21	K.Z	J.Z

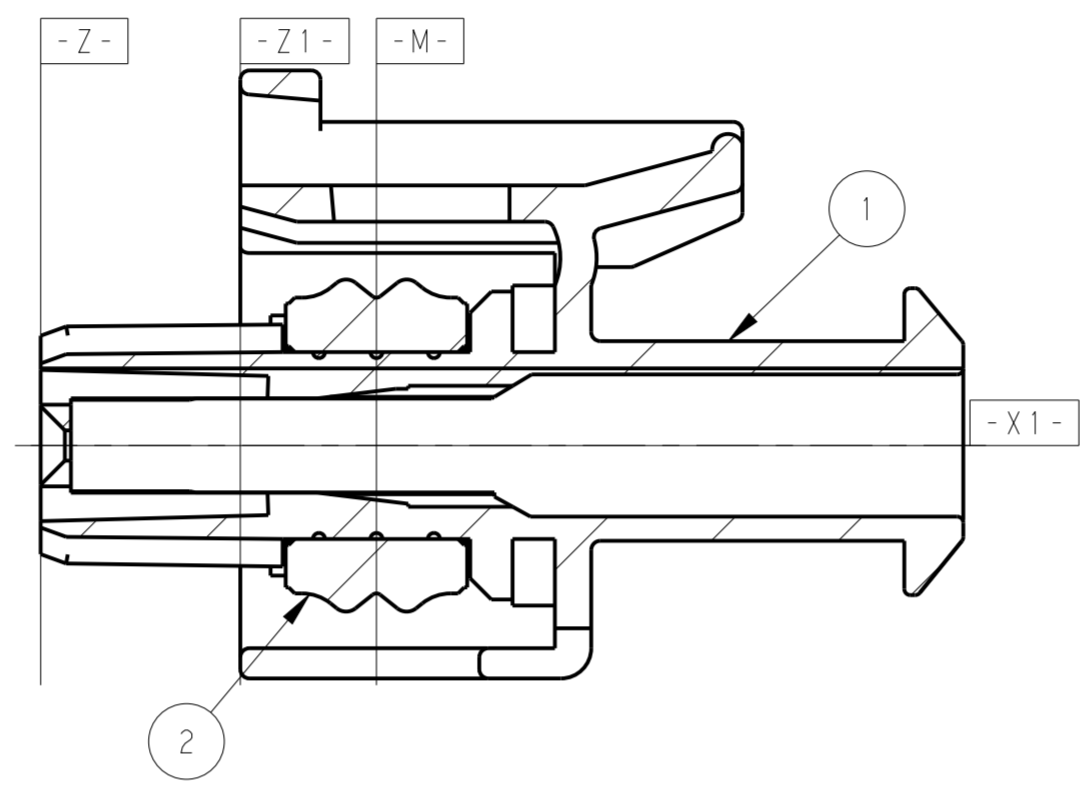
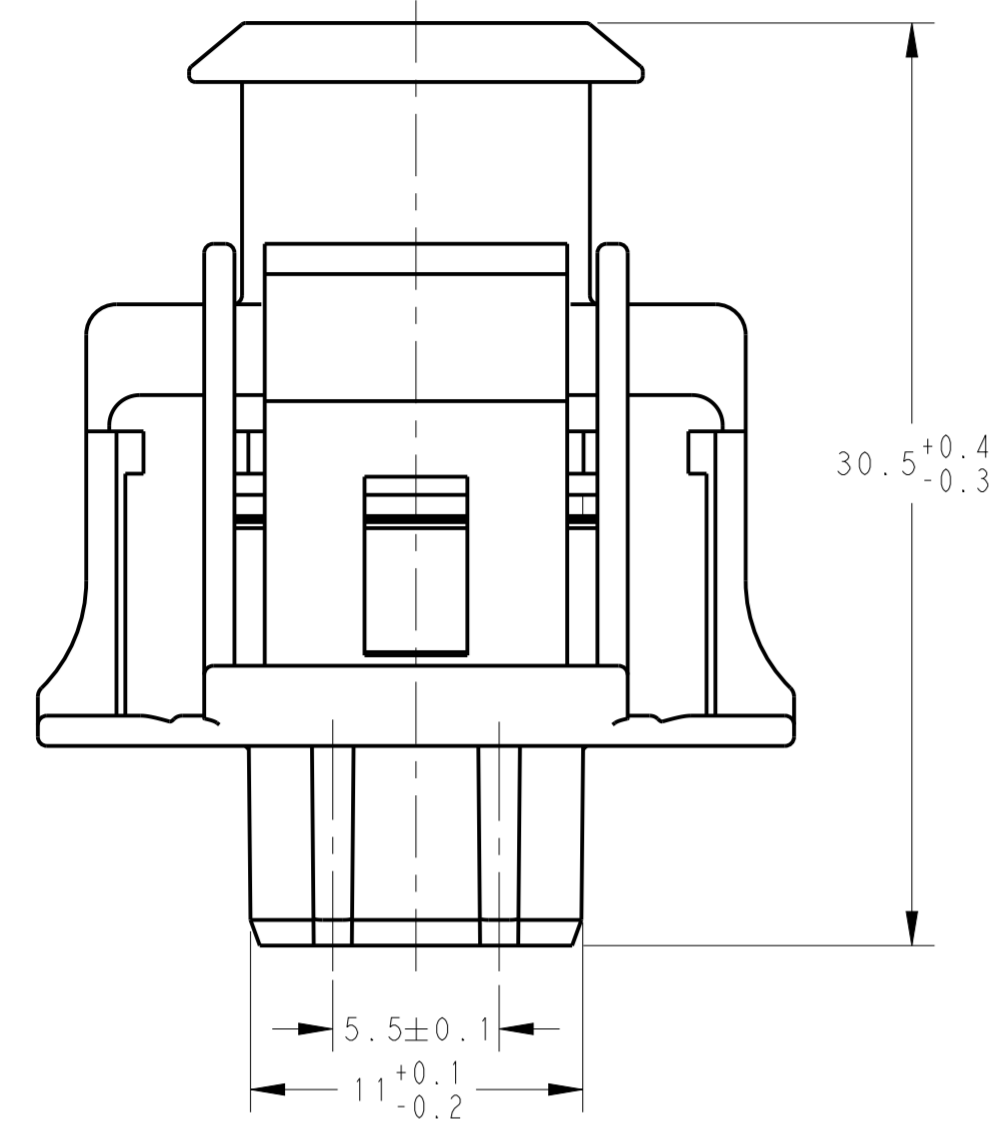
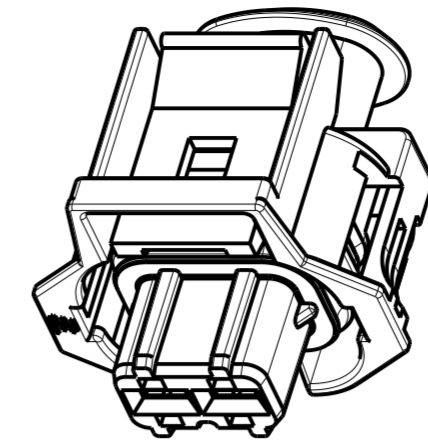

SECTION A - A
SCALE 4:1

NOTE:
 1. CODING IS AS FOLLOWS, SEE TABLE 1.

2. APPLIED RECEPTACLE CONTACT P/N:

DESCRIPTION	2.8mm SENSOR-FLAT RECEPTACLE OR EQUIVALENT	
PART NO.	967542 OR EQU.	967543 OR EQU.
WIRE SIZE	0.5~1.0	>1.0~2.5

3. APPLIED WIRE SEAL P/N:

DESCRIPTION	SINGLE-WIRE SEAL (5mm HOLE)	
PART NO.	828904	828905
INSULATION DIA.(∅)	1.2~2.1mm	2.2~3.0mm

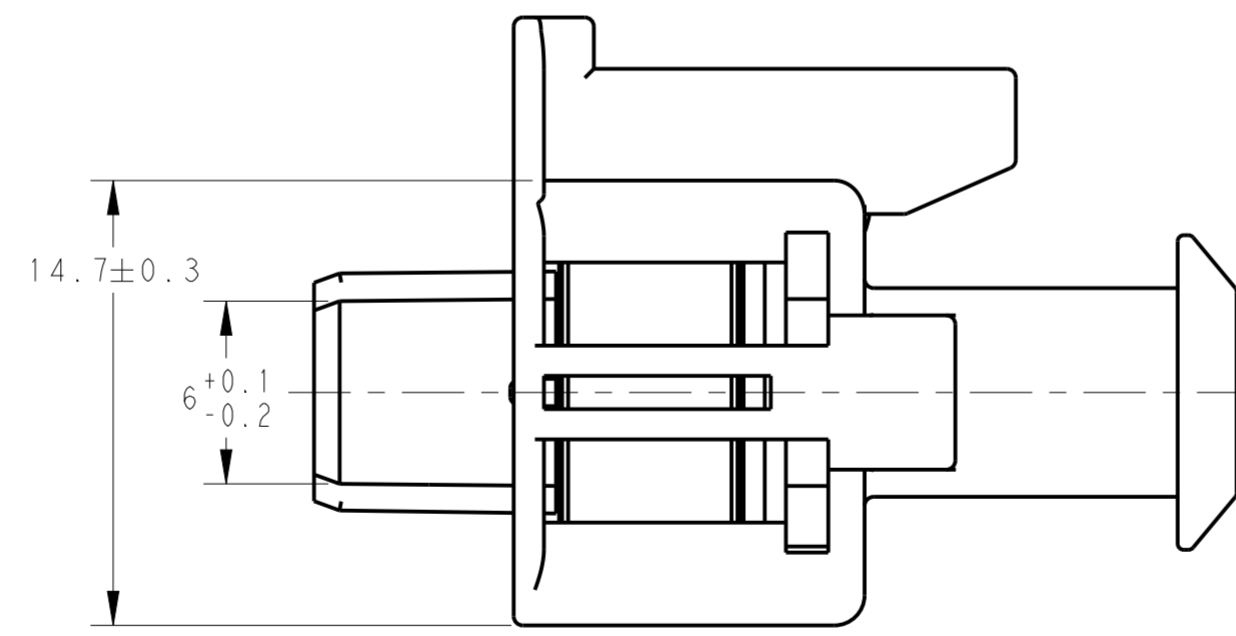
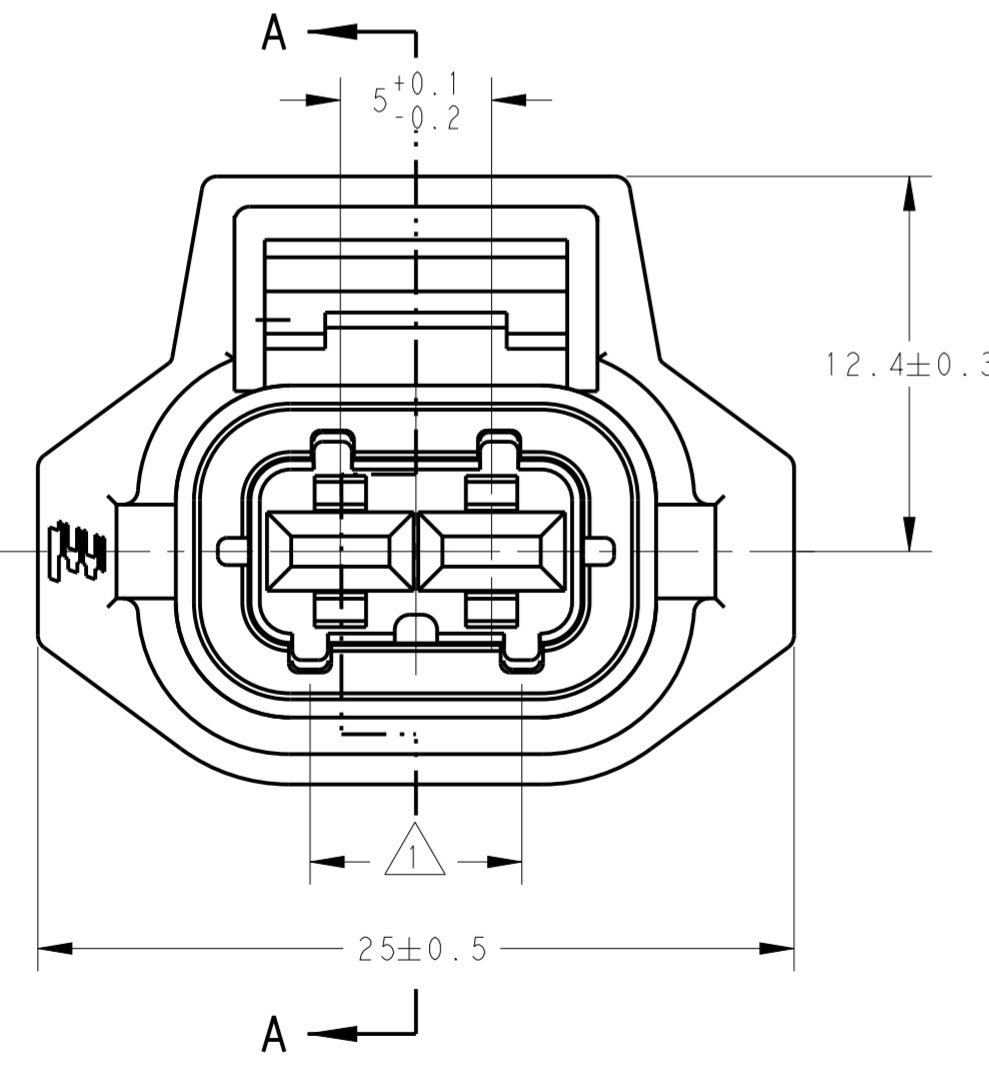

(TABLE 1)

CODE 1	2050046-1/3	CODE 2	2050046-2/4

1	1	1	1	PC	ORANGE	SILICON	INNER SEAL	2
1				PC	WHITE	PA66 GF15	PLUG (CODE 2)	1
	1			PC	BROWN	PA66 GF15	PLUG (CODE 1)	1
		1		PC	BLACK	PA66 GF15	PLUG (CODE 2)	1
			1	PC	BLACK	PA66 GF15	PLUG (CODE 1)	1
-4	-3	-2	-1	U/M	COLOR	MATERIAL	DESCRIPTION	ITEM

THIS DRAWING IS A CONTROLLED DOCUMENT.

DIMENSIONS:	TOLERANCES UNLESS OTHERWISE SPECIFIED:	DWN	Q. HAN	27AUG18		TE Connectivity		
mm	0 PLC ±0.30	CHK	G. ZHU	27AUG18				
	1 PLC ±0.30	APVD	F. JIANG	27AUG18				
	2 PLC ±	PRODUCT SPEC	108-101133-1 (A1)					
	3 PLC ±	APPLICATION SPEC			NAME	2.8mm SEALED 2P PLUG ASSEMBLY		
	4 PLC ±				SIZE	CAGE CODE	DRAWING NO	RESTRICTED TO
MATERIAL	ANGLES ±3°	WEIGHT			A2	00779	C-2050046	
	FINISH	CUSTOMER DRAWING			SCALE	1:1	SHEET	1 OF 2

THIS DRAWING IS UNPUBLISHED. RELEASED FOR PUBLICATION 20
 © COPYRIGHT 20 BY - ALL RIGHTS RESERVED.

REVISIONS				
P	LTR	DESCRIPTION	DATE	APVD
		SEE SHEET 1		

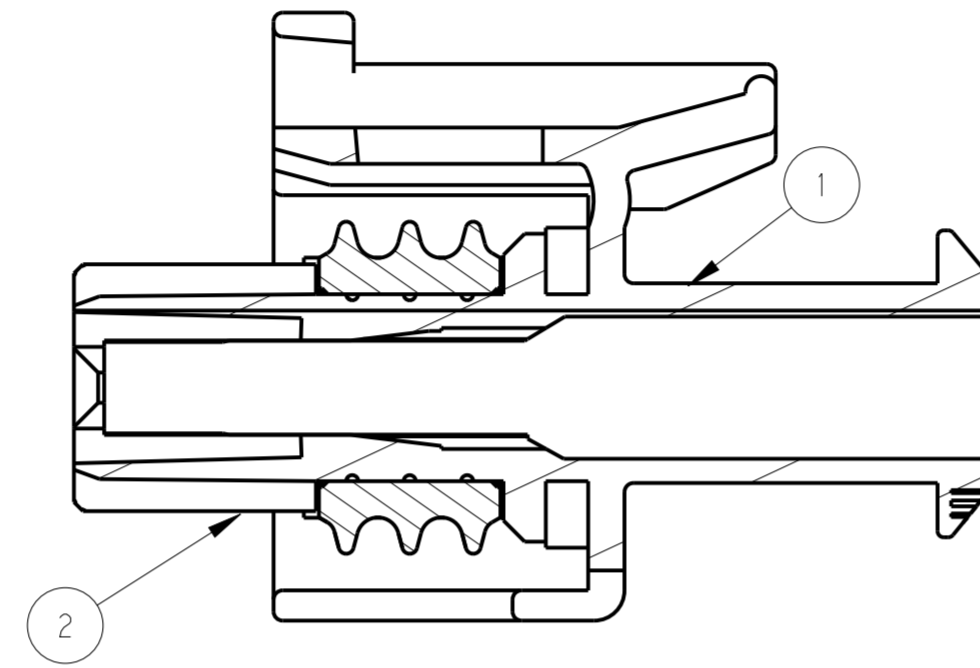
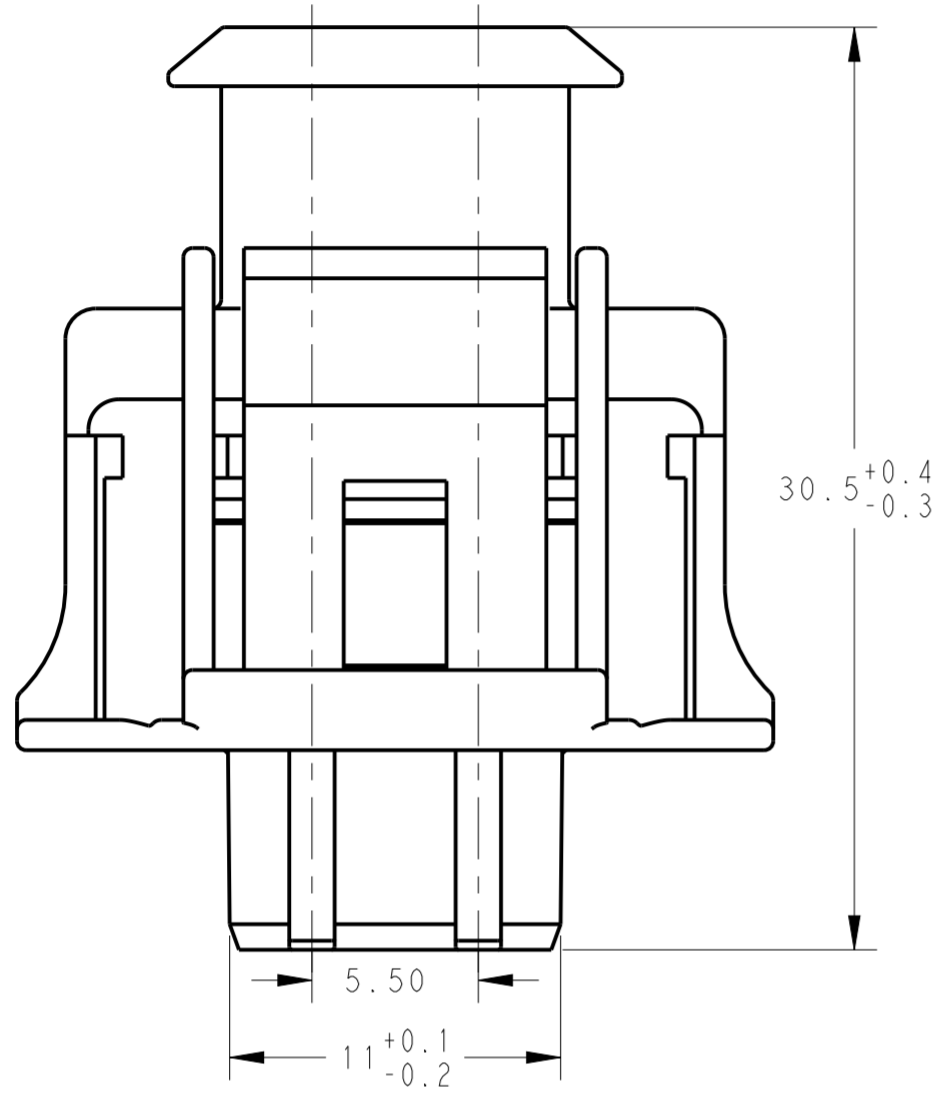
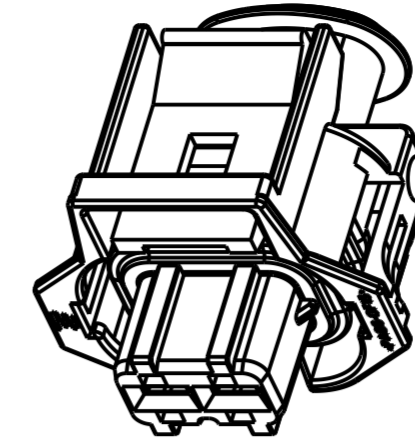

SECTION: A-A
SCALE: 4:1

NOTE:

1. CODING IS AS FOLLOWS, SEE TABLE 1.

2. APPLIED RECEPTACLE CONTACT P/N:

DESCRIPTION	2.8mm SENSOR-FLAT RECEPTACLE OR EQUIVALENT	
PART NO.	967542 OR EQU.	967543 OR EQU.
WIRE SIZE	0.5~1.0	>1.0~2.5

3. APPLIED WIRE SEAL P/N:

DESCRIPTION	SINGLE-WIRE SEAL (5mm HOLE)	
PART NO.	828904	828905
INSULATION DIA. (∅)	1.2~2.1mm	2.2~3.0mm

(TABLE 1)

CODE 1	1-2050046-1/3	CODE 2	1-2050046-2/4

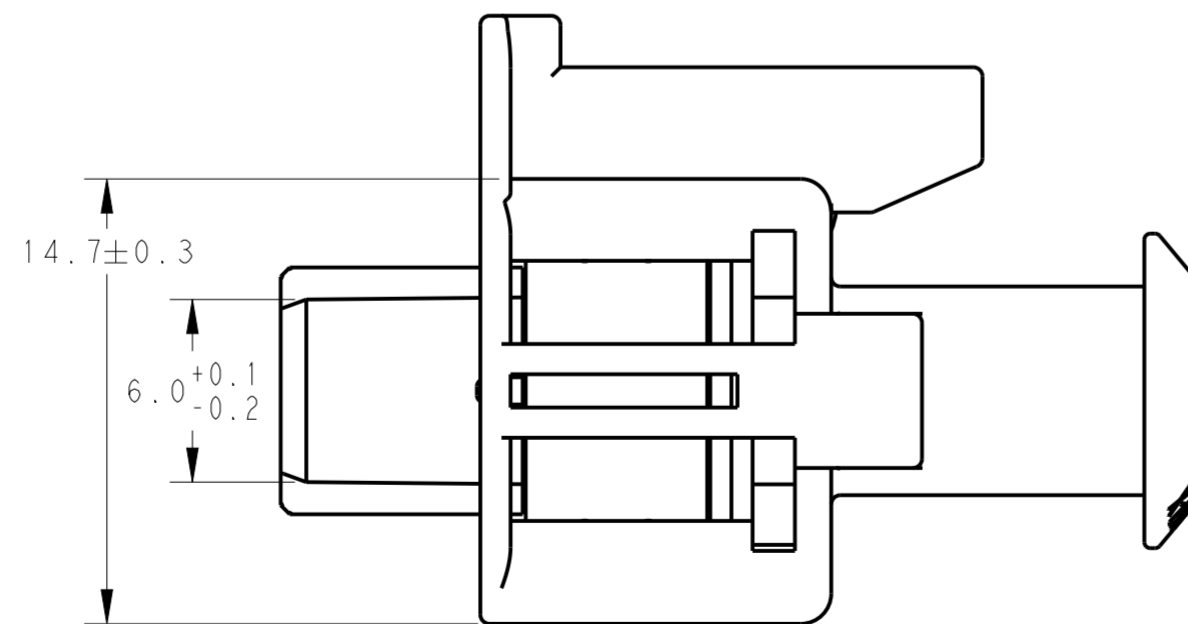
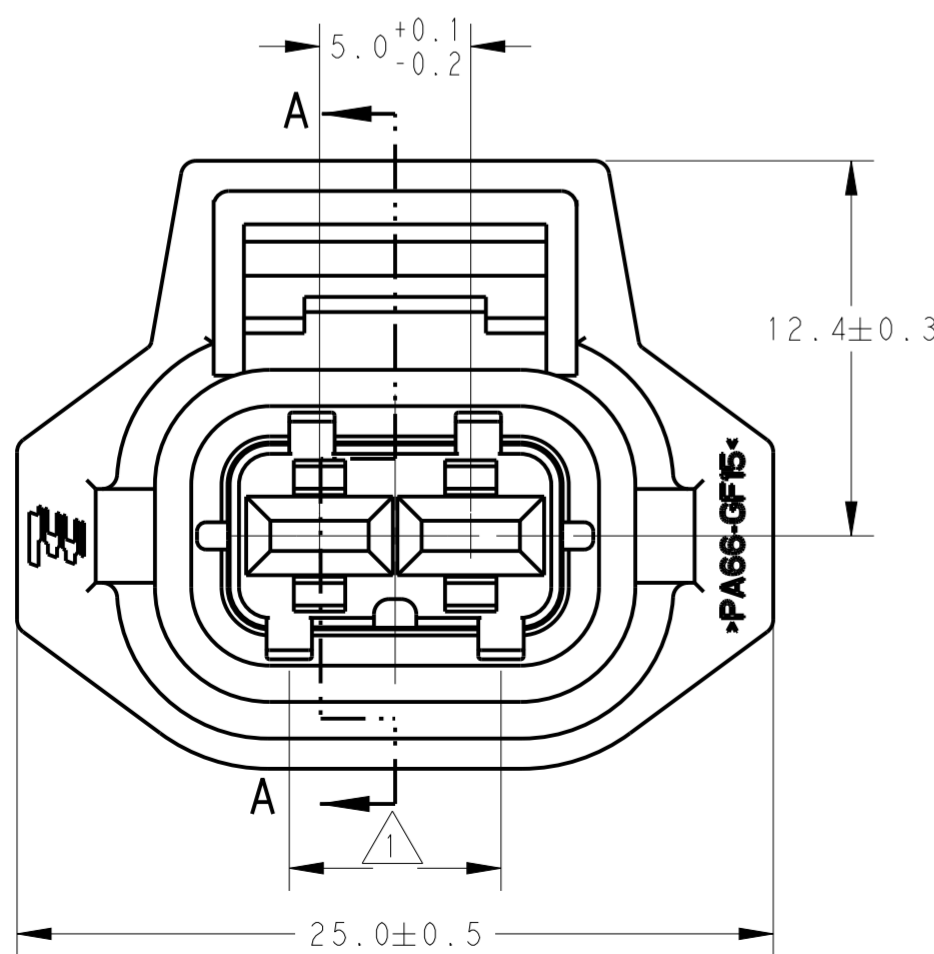

1	1	1	1	PC	ORANGE	SILICON	INNER SEAL	2	
1				PC	WHITE	PA66 GF15	PLUG (CODE 2)	1	
	1			PC	BROWN	PA66 GF15	PLUG (CODE 1)	1	
		1		PC	BLACK	PA66 GF15	PLUG (CODE 2)	1	
			1	PC	BLACK	PA66 GF15	PLUG (CODE 1)	1	
1-2050046-4				1-2050046-3				1-2050046-2	
1-2050046-1				U/M				COLOR MATERIAL DESCRIPTION ITEM	

THIS DRAWING IS A CONTROLLED DOCUMENT.

DIMENSIONS: mm	TOLERANCES UNLESS OTHERWISE SPECIFIED:	DWN: K. ZHOU 28MAY21	CHK: T. DONG 28MAY21	APVD: J. ZONG 28MAY21	PRODUCT SPEC: 108-101133-1	APPLICATION SPEC: -	WEIGHT: -	CUSTOMER DRAWING
0 PLC ±0.30 1 PLC ±0.30 2 PLC ± 3 PLC ± 4 PLC ± ANGLES ±3° FINISH		TE Connectivity NAME: 2.8mm SEALED 2P PLUG ASSEMBLY SIZE: A2 CAGE CODE: 00779 DRAWING NO: C-2050046 RESTRICTED TO: A2			SCALE: 1:1 SHEET: 2 OF 2 REV: A2			