

4

3

2

1

THIS DRAWING IS UNPUBLISHED. RELEASED FOR PUBLICATION AUG, 2006.
 © COPYRIGHT - BY TYCO ELECTRONICS CORPORATION. ALL RIGHTS RESERVED.

LOC DW	DIST /	REVISIONS		
P	LTR	DESCRIPTION	DATE	DWN
	A	RELEASED	28SEP'10	E.L.
				APVD W.K.

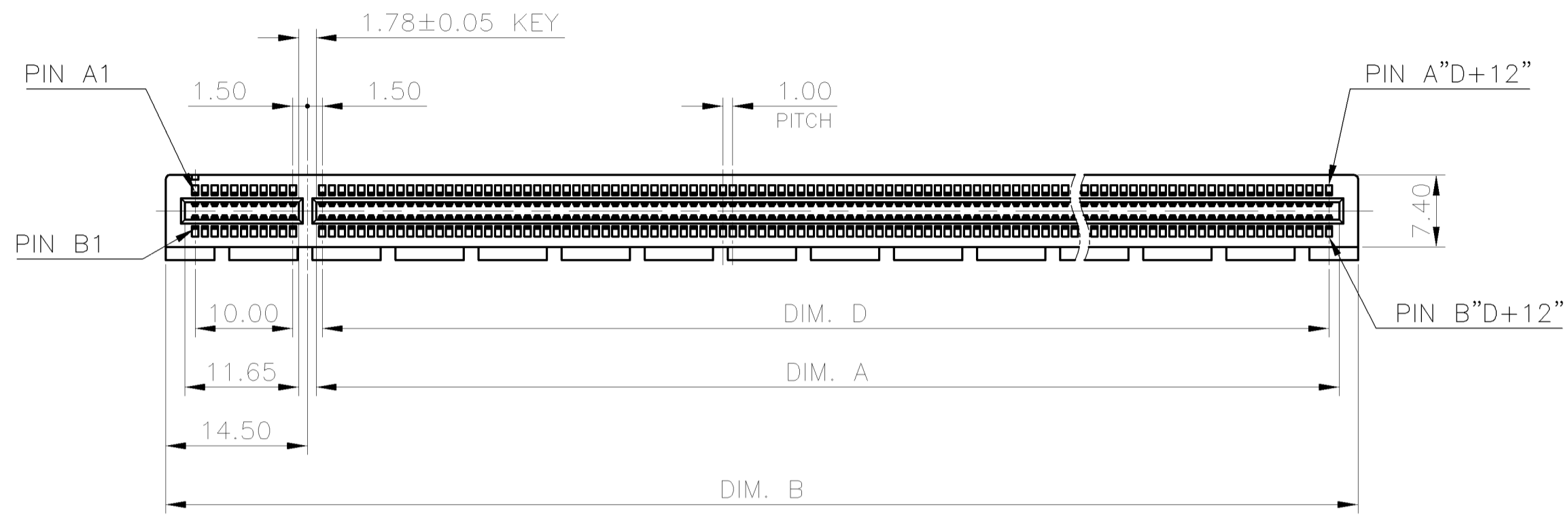

- NOTES:
- MATERIAL:
 - HOUSING: PA46 WITH 40% G.F, UL94 V-0; COLOR: BLACK
 - CONTACT: BRASS
 - BOARDLOCKS: BRASS
 - FINISH:
 - CONTACT:
 - GOLD PLATING (SEE TABLE) ON CONTACT AREA.
 - 2.54um[100u"] MIN. MATTE-TIN PLATING ON SOLDER TAIL AREA.
 - 1.27um[50u"] MIN. NICKEL UNDERPLATING OVERALL.
 - BOARDLOCK:
 - 2.54um[100u"] MIN. MATTE-TIN PLATING.
 - 1.27um[50u"] MIN. NICKEL UNDERPLATING OVERALL.
 - WAVE SOLDER CAPABLE TO 265°C PER TE SPEC. 109-202, CONDITION B.

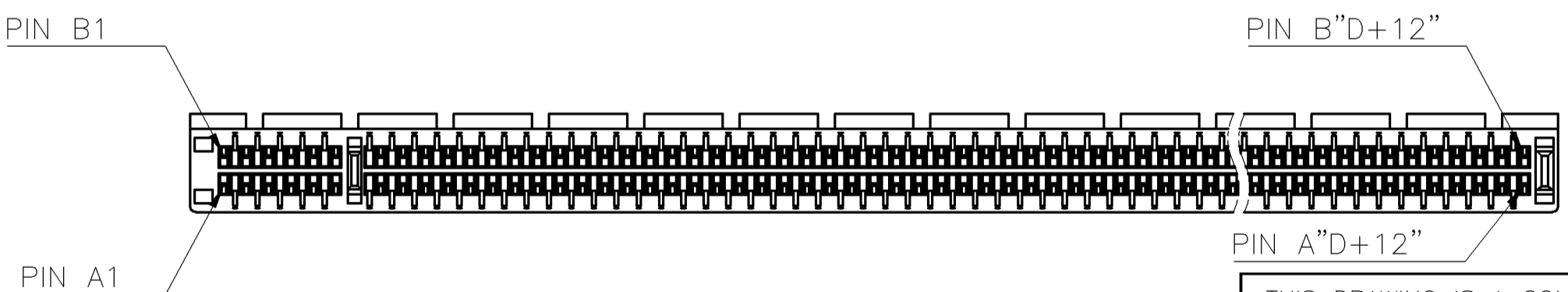
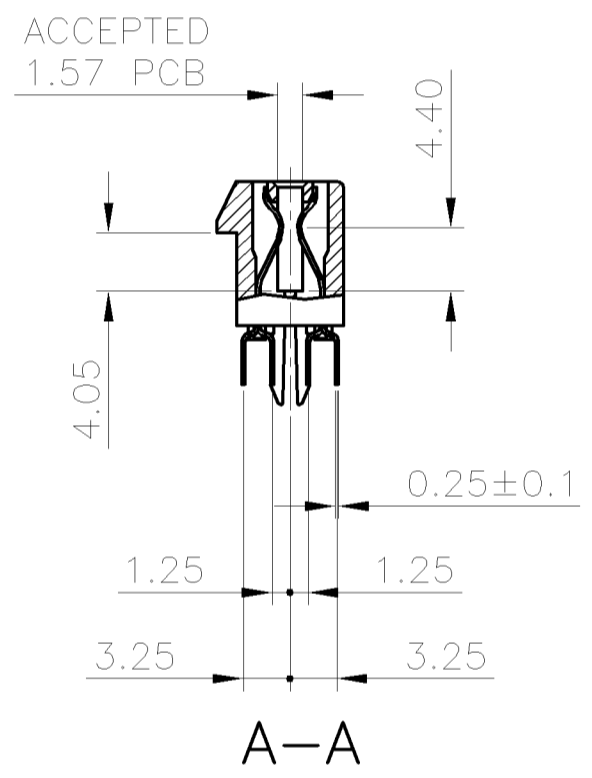
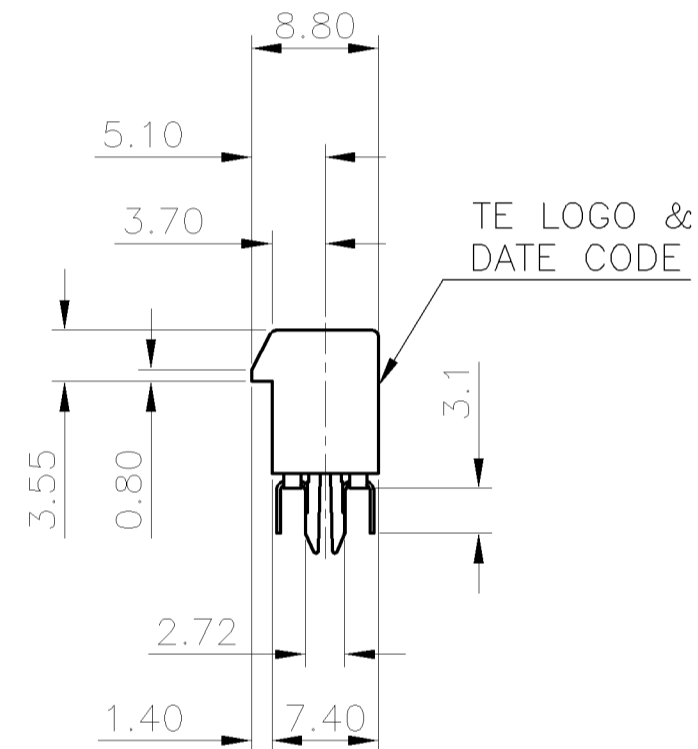
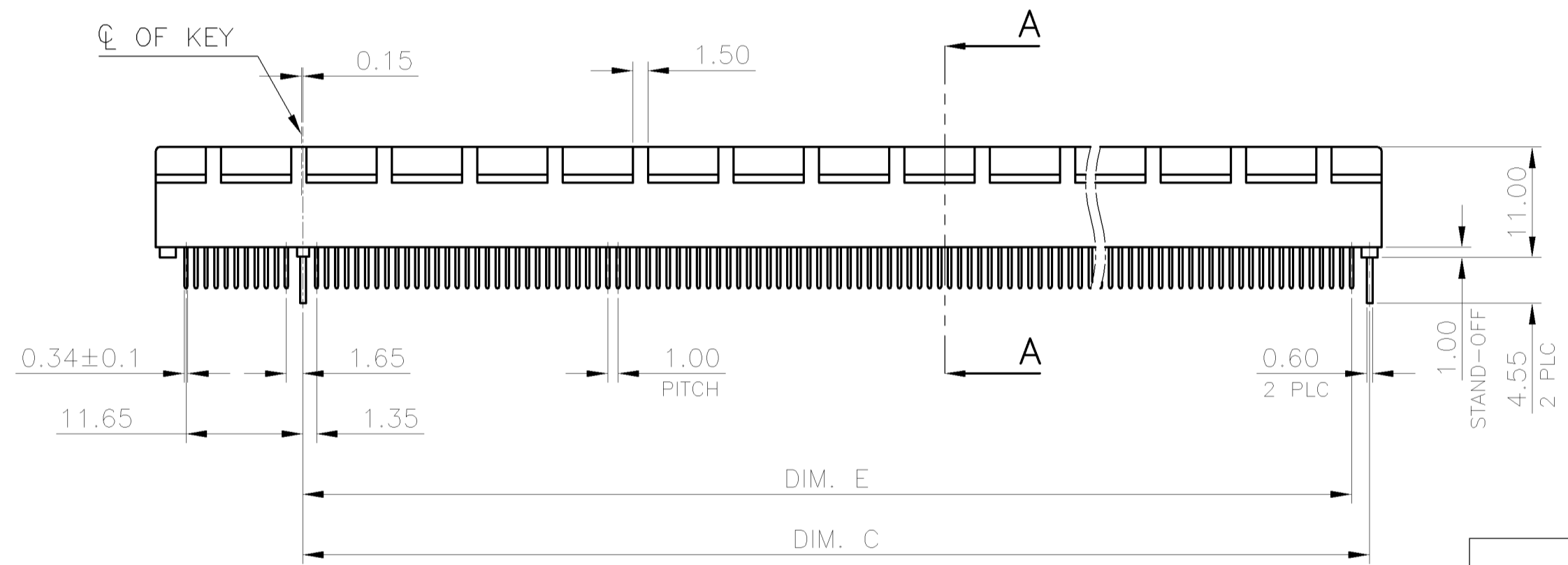

13.5	109.35	108.00	111.15	127.00	109.68	0.381um[15u"]	240	2041237-5
						0.762um[30u"]		2041237-4
12.3	104.35	103.00	106.15	122.00	104.68	0.381um[15u"]	230	2014237-2
						0.762um[30u"]		2041237-1
NET WEIGHT(g)	DIM. E	DIM. D	DIM. C	DIM. B	DIM. A	MIN. GOLD THICKNESS	POS.	PART NUMBER

THIS DRAWING IS A CONTROLLED DOCUMENT.

DIMENSIONS: MM	TOLERANCES UNLESS OTHERWISE SPECIFIED:	DWN E. LIU 28SEP2010	Tyco Electronics Corporation Taipei, Taiwan
	0 PLC ± -	CHK S. CHIEN 28SEP2010	
	1 PLC ± 0.3	APVD W. KODAMA 28SEP2010	
2 PLC ± 0.2	PRODUCT SPEC 108-57787	NAME	
3 PLC ± 0.15	APPLICATION SPEC	SIZE	
4 PLC ± -	ANGLES ± 3'	CAGE CODE	
MATERIAL SEE NOTE	FINISH SEE NOTE	DRAWING NO	RESTRICTED TO
		WEIGHT SEE TABLE	
		CUSTOMER DRAWING	

SCALE: - SHEET: 1 OF 3 REV: A

THIS DRAWING IS UNPUBLISHED.

RELEASED FOR PUBLICATION AUG ,2006.

LOC DW DIST

REVISIONS

© COPYRIGHT BY TYCO ELECTRONICS CORPORATION. ALL RIGHTS RESERVED.

P	LTR	DESCRIPTION	DATE	DWN	APVD
		SEE SHEET 1.			

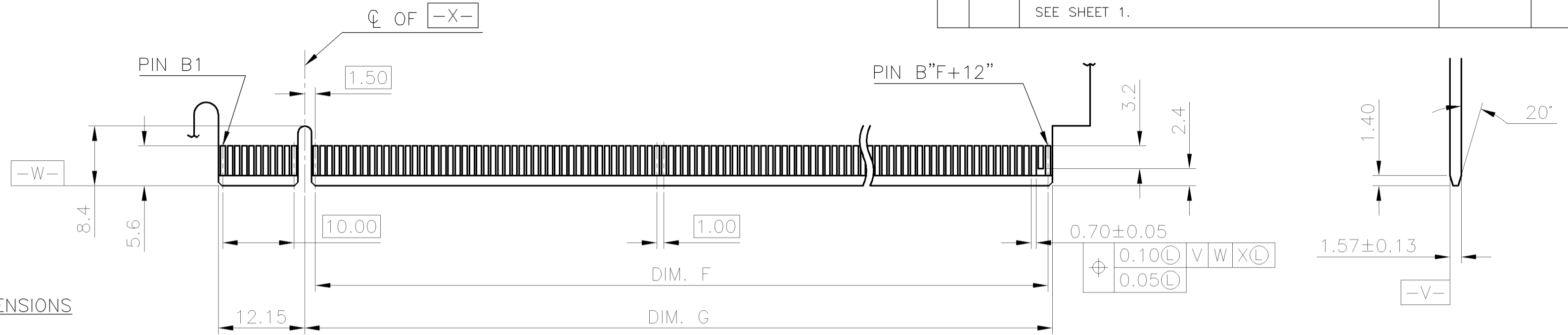

NOTES:
CHAMFER EDGE MUST BE FREE OF CUTTING BURRS

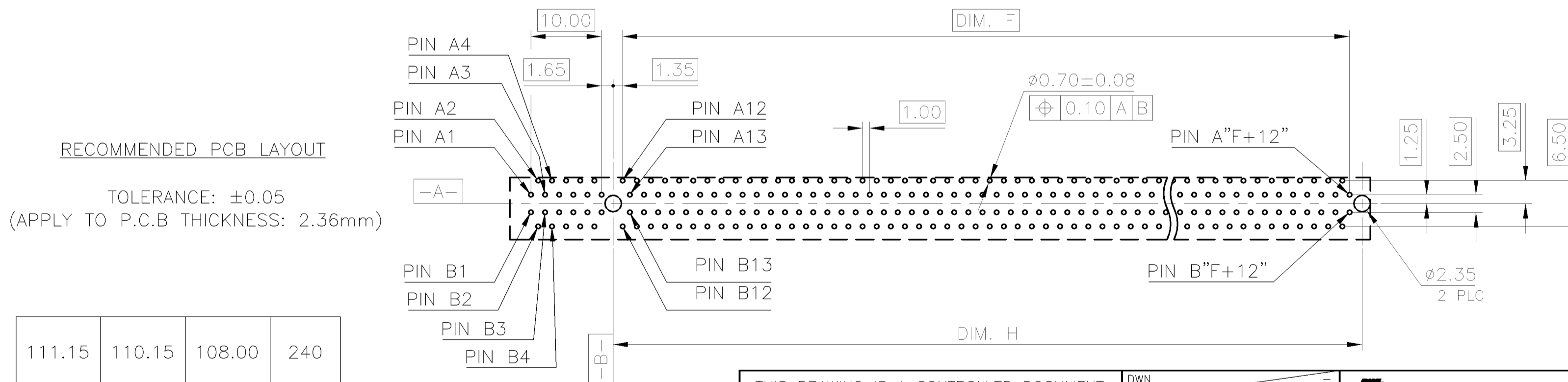
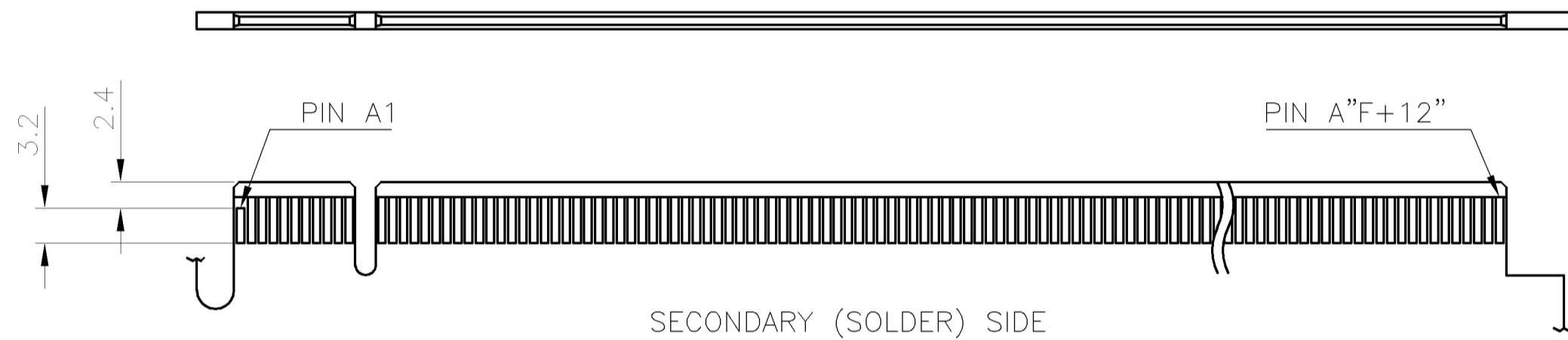

111.15	110.15	108.00	240
106.15	105.15	103.00	230
DIM. H	DIM. G	DIM. F	POS.

THIS DRAWING IS A CONTROLLED DOCUMENT.		DWN	Tyco Electronics		Tyco Electronics Corporation Taipei, Taiwan	
DIMENSIONS: MM		CHK	NAME			
TOLERANCES UNLESS OTHERWISE SPECIFIED:		APVD	PCI EXPRESS CARD EDGE CONNECTOR EXTENDED, VERTICAL, DIP TYPE			
0 PLC ± -		PRODUCT SPEC	SIZE	CAGE CODE	DRAWING NO	RESTRICTED TO
1 PLC ± -		APPLICATION SPEC	A3	00779	C=2041237	
2 PLC ± -		WEIGHT	CUSTOMER DRAWING			
3 PLC ± -			SCALE	SHEET	REV	
4 PLC ± -				2 OF 3	A	
ANGLES ± -						
FINISH						

LOC DW DIST

REVISIONS

P	LTR	DESCRIPTION	DATE	DWN	APVD
		SEE SHEET 1.			

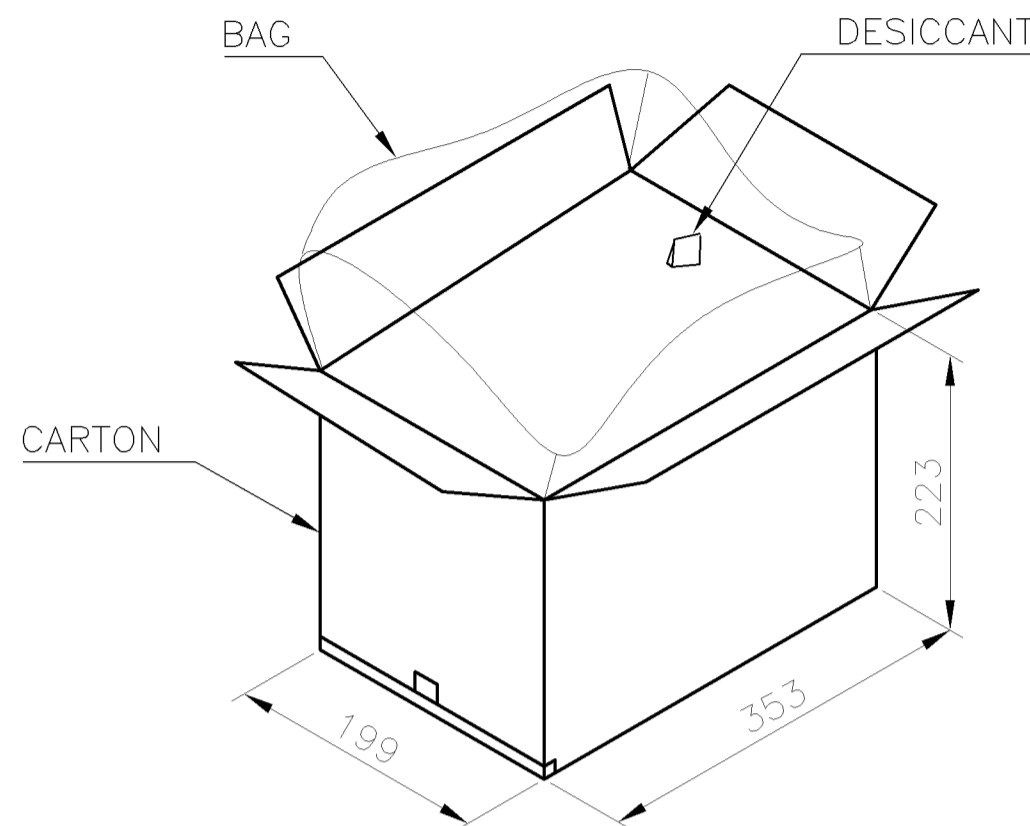
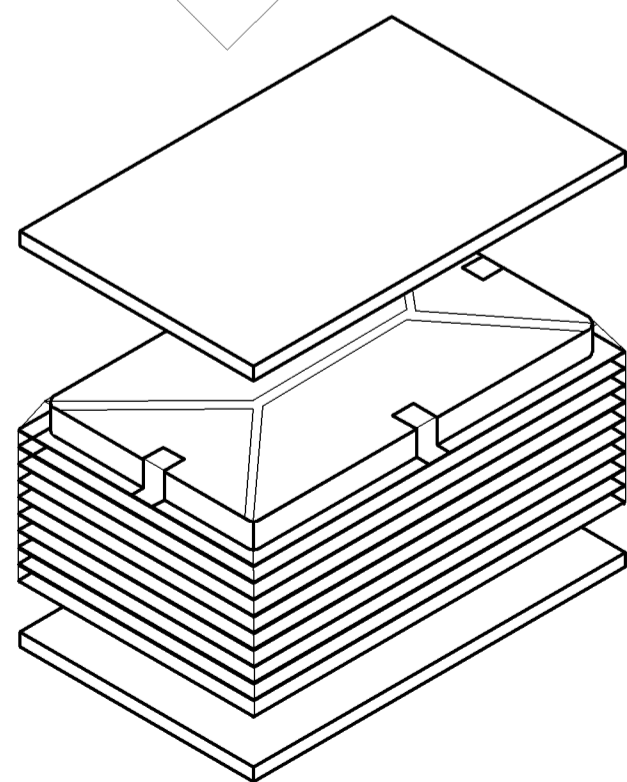
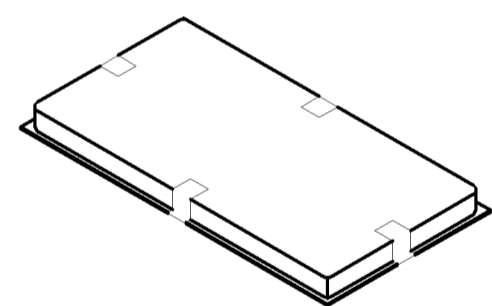
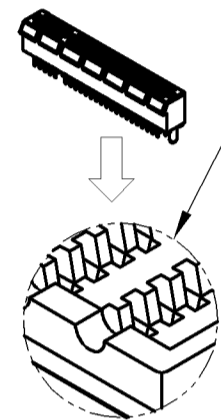
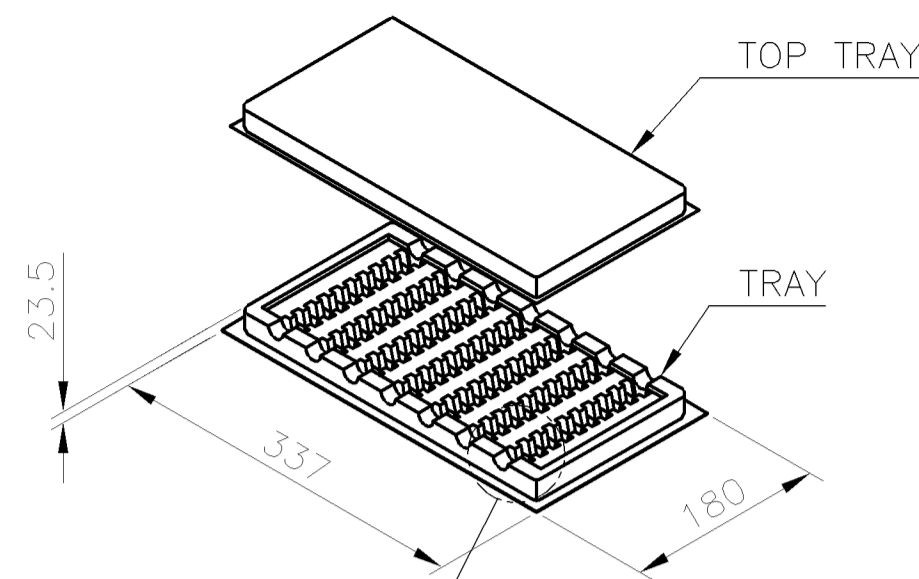

- MATERIAL :
 TRAY: PVC, COLOR: TRANSPARENT.
 CARTON: CORRUGATED FIBER
 BOX: CORRUGATED FIBER
 TRANSPARENT BAG: PE, SIZE: 480mm*350mm*0.06mm
 600mm*590mm*0.06mm
- EACH BAG SHALL BE INCLUDED:
 * DESICCANT

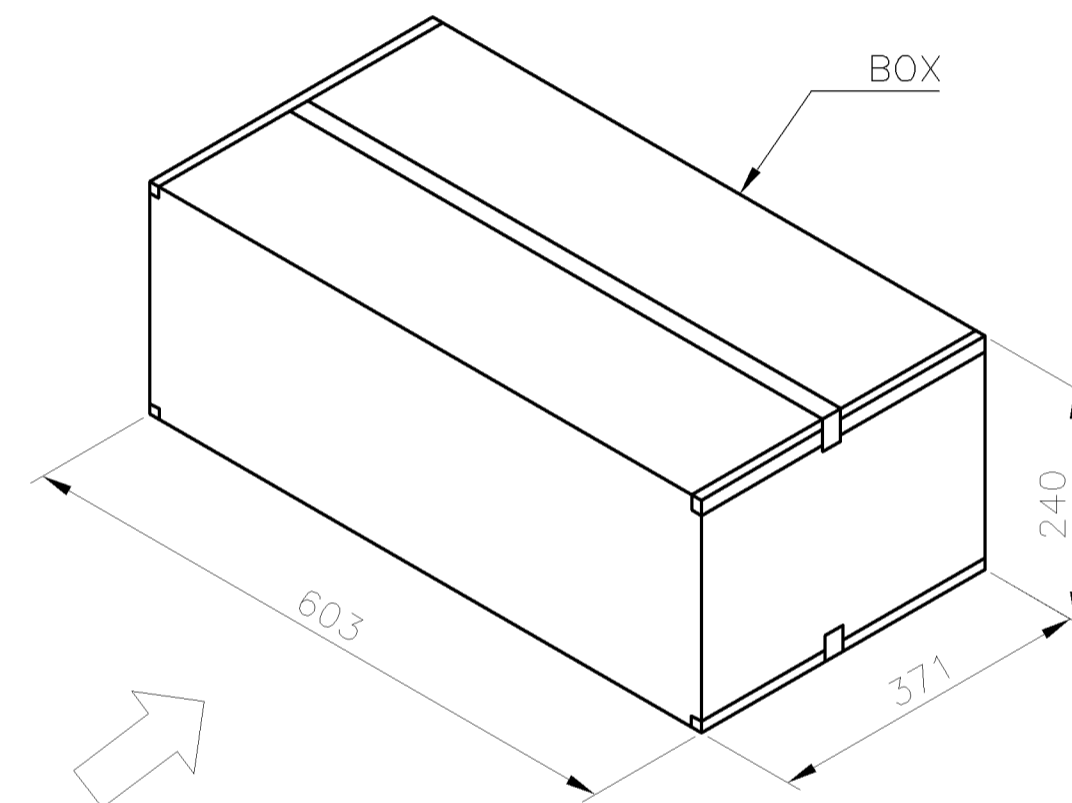
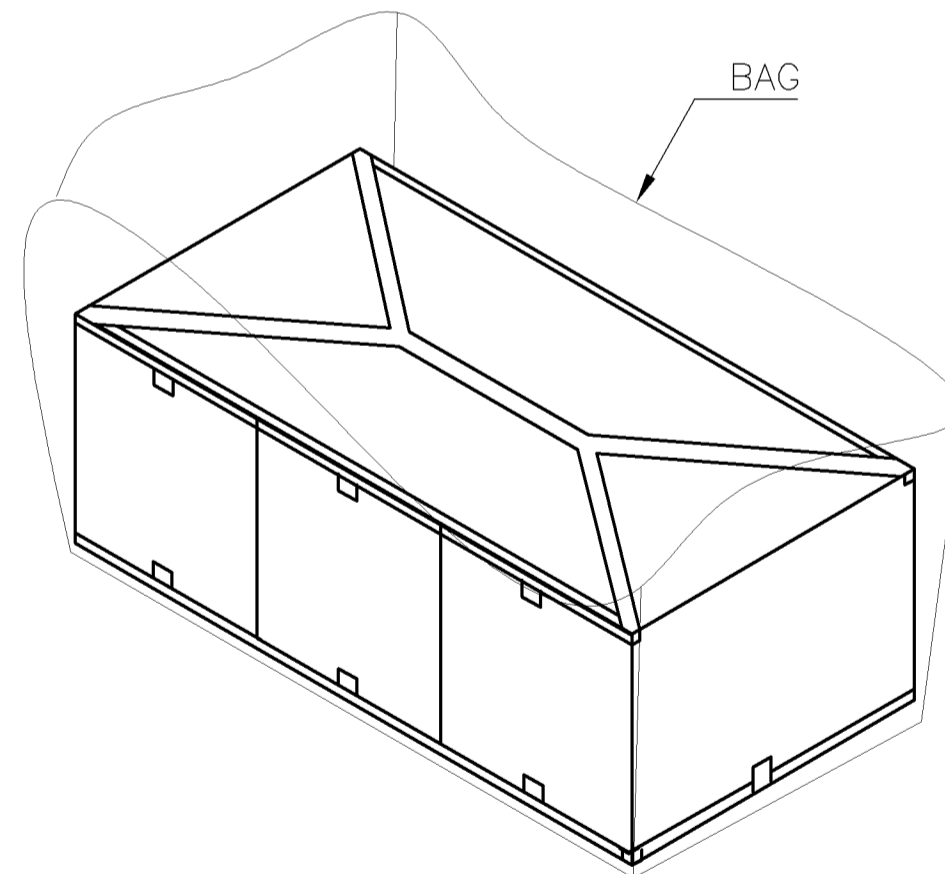

15.0 KG	8.1 KG	20	10	3	600	240
14.3 KG	7.4 KG	20	10	3	600	230
GROSS WEIGHT	NET WEIGHT	PCS/ TRAY	TRAY/ CARTON	CARTON/ BOX	PCS/ BOX	POS

THIS DRAWING IS A CONTROLLED DOCUMENT.		DWN	Tyco Electronics Corporation Taipei, Taiwan			
DIMENSIONS: MM		CHK	NAME			
TOLERANCES UNLESS OTHERWISE SPECIFIED:		APVD	PCI EXPRESS CARD EDGE CONNECTOR EXTENDED, VERTICAL, DIP TYPE			
0 PLC ± -		PRODUCT SPEC	SIZE	CAGE CODE	DRAWING NO	RESTRICTED TO
1 PLC ± -		APPLICATION SPEC	A3	00779	C=2041237	
2 PLC ± -		WEIGHT	CUSTOMER DRAWING			
3 PLC ± -			SCALE	SHEET	REV	
4 PLC ± -			-	3 OF 3	A	
ANGLES ± -						
FINISH						