

© 1963 BY AMP INCORPORATED. ALL RIGHTS RESERVED. AMP PRODUCTS COVERED BY PATENTS AND/OR PATENTS PENDING. APPROVED PER GOVT CONTRACT NO.

REVISIONS				
SYM	ZONE	DESCRIPTION	DATE	APPROVAL
O		RELEASED C-202383-1 WAS $\frac{1}{2}$ M5001-540-1	12-2-63	JK
A		REV. PER ECN D-644	6-30-75	B/PM
B		REV. PER ECN E-928	APR 1957M	PM
C		REV PER ECN BD 4273	9-25-90	UB

#4-40 UNC SCREW (FIL. HEAD)  
ZINC PLATED COLD ROLLED STL.  
(2 REQ'D.)

#4-40 UNC. SCREW  
(PAN HEAD) SST, PASSIVATED  
(2 REQ'D)

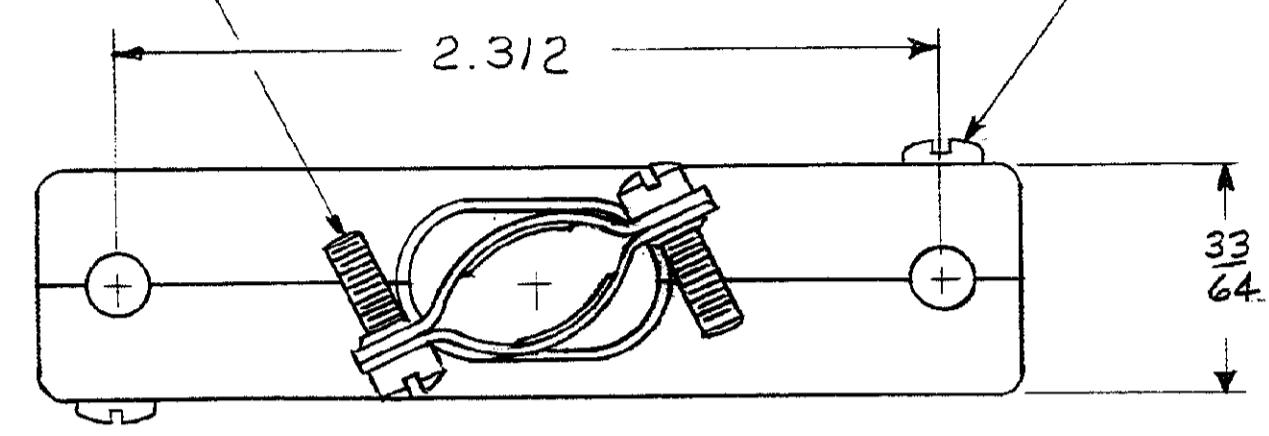

CABLE CLAMP (IN HALVES)  
C.R. STEEL : ZINC PLATED

SHIELD (IN HALVES)  
C.R. STEEL : ZINC PLATED

AMP STAMP & PART NO.  
STAMPED IN THIS AREA

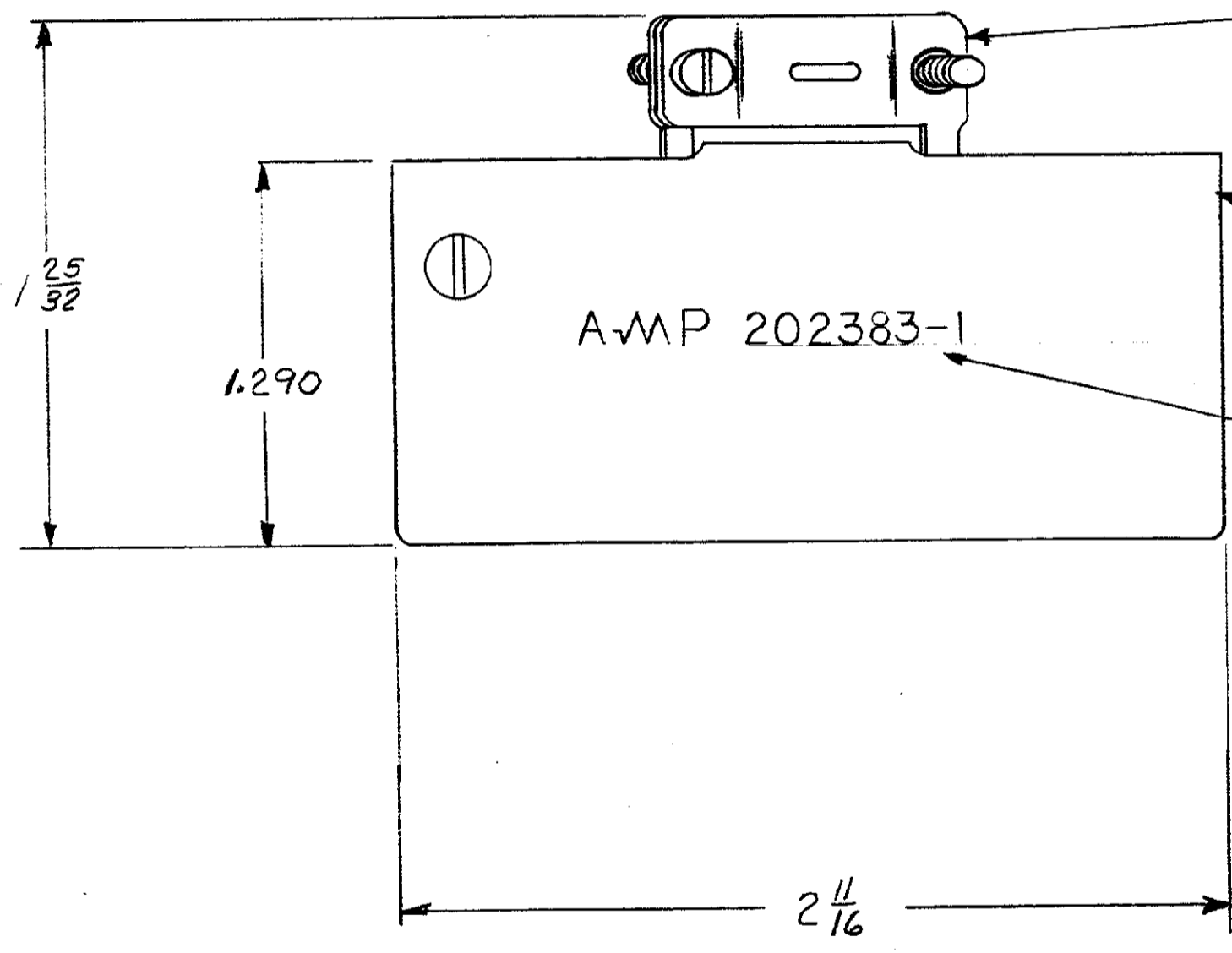

1. CLAMP WILL ACCEPT  $\frac{7}{16}$  DIA. CABLE:
2. PARTS ARE PACKAGED UNASSEMBLED.

AMP INFO	QTY REQD	NOMENCLATURE OR DESCRIPTION	PART OR IDENTIFYING NO	LIST OF MATERIALS OR PARTS LIST	
BD 39					
UNLESS OTHERWISE SPECIFIED DIMENSIONS ARE IN INCHES		SIGNATURE		DATE	AMP INCORPORATED HARRISBURG, PENNSYLVANIA NAME: SHIELD KIT, 41 POSITION, UNASSEMBLED, NARROW, M SERIES
FRACTIONS $\pm \frac{1}{64}$	DECIMALS $\pm .015$	ANGLES $\pm \frac{1}{2}^\circ$	DR: <i>R. Miller</i>	10-21-63	
MATERIAL: SEE CALLOUT			CHK: <i>J. Kauf</i>	6-2-63	
HEAT TREAT: —			DESIGN ENGR: <i>R. Hartman</i>	7-31-63	
FINISH: —			APPR: <i>CCusto</i>	7-31-63	CODE IDENT NO: 00779 SIZE: C NUMBER: 202383-1
OTHER APPD: —			SCALE: 2-1		SHEET: — CUSTOMER DRAWING