

REVISIONS					
P	LTR	DESCRIPTION	DATE	DWN	APVD
4		ADDED 350MM LENGTH	13MAR2022	CL	WH

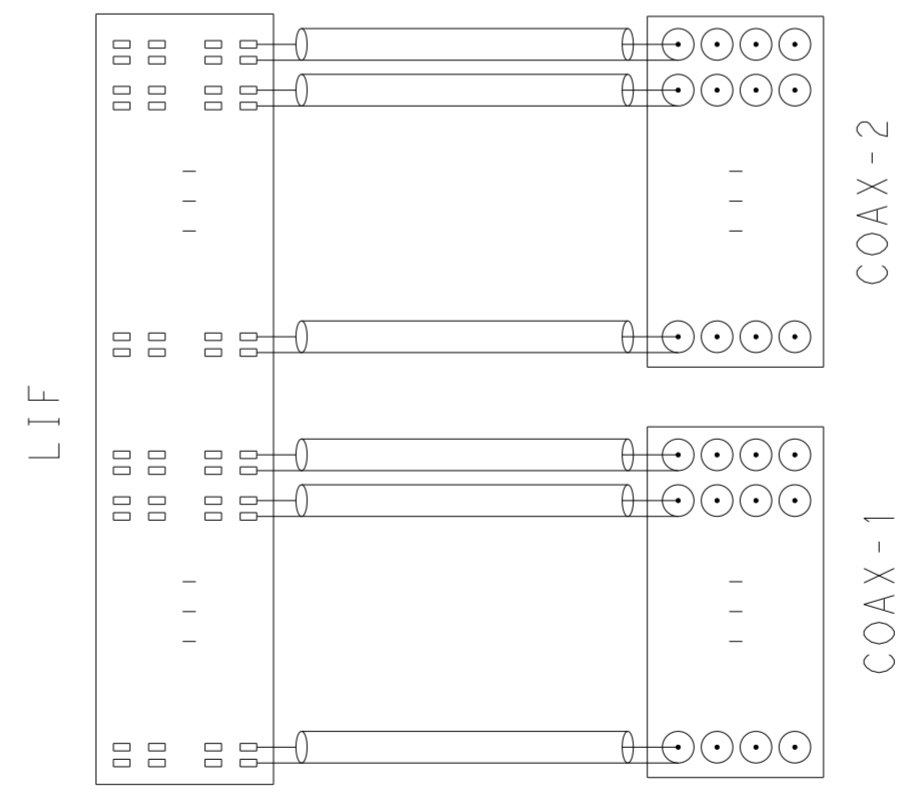
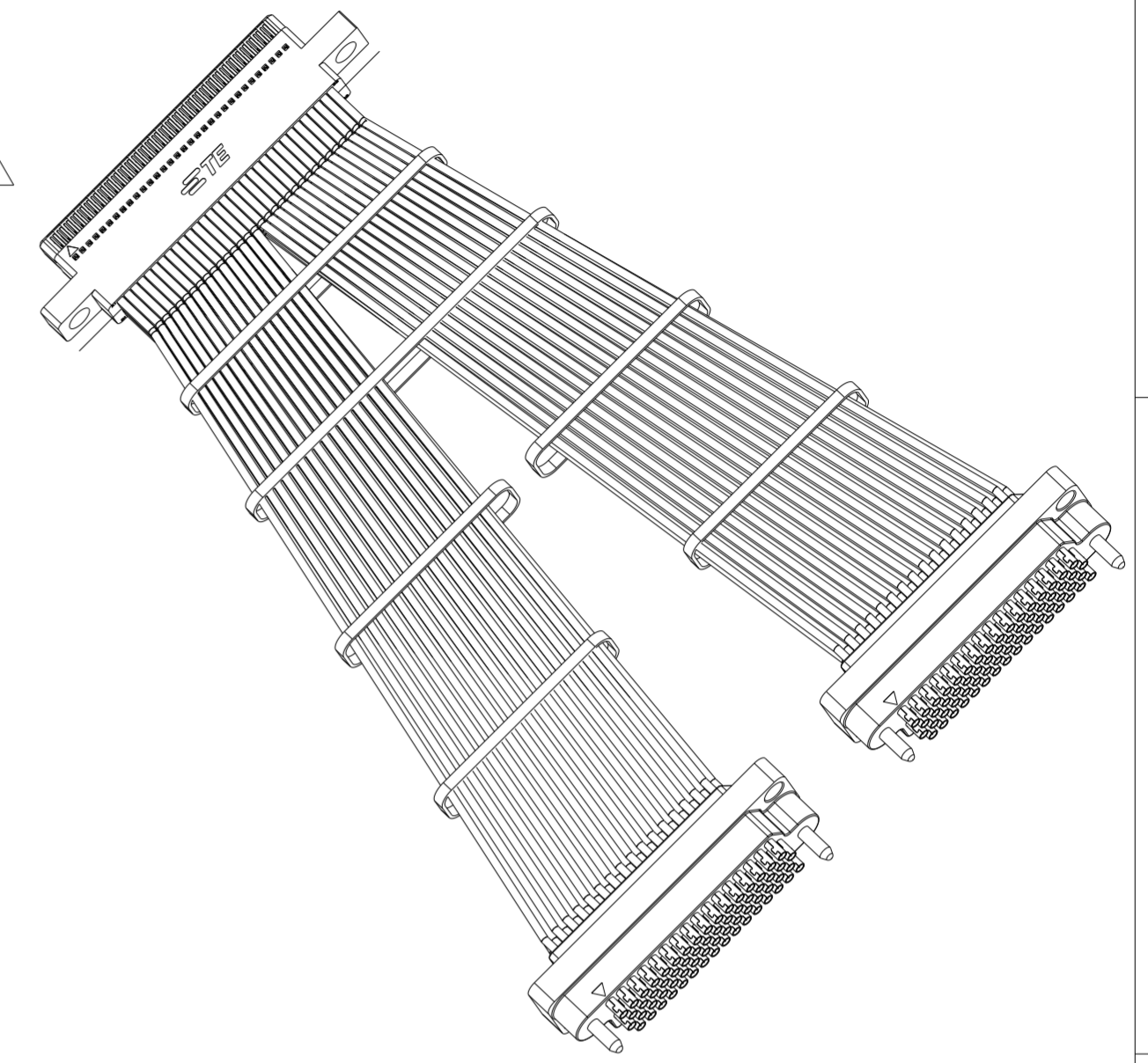
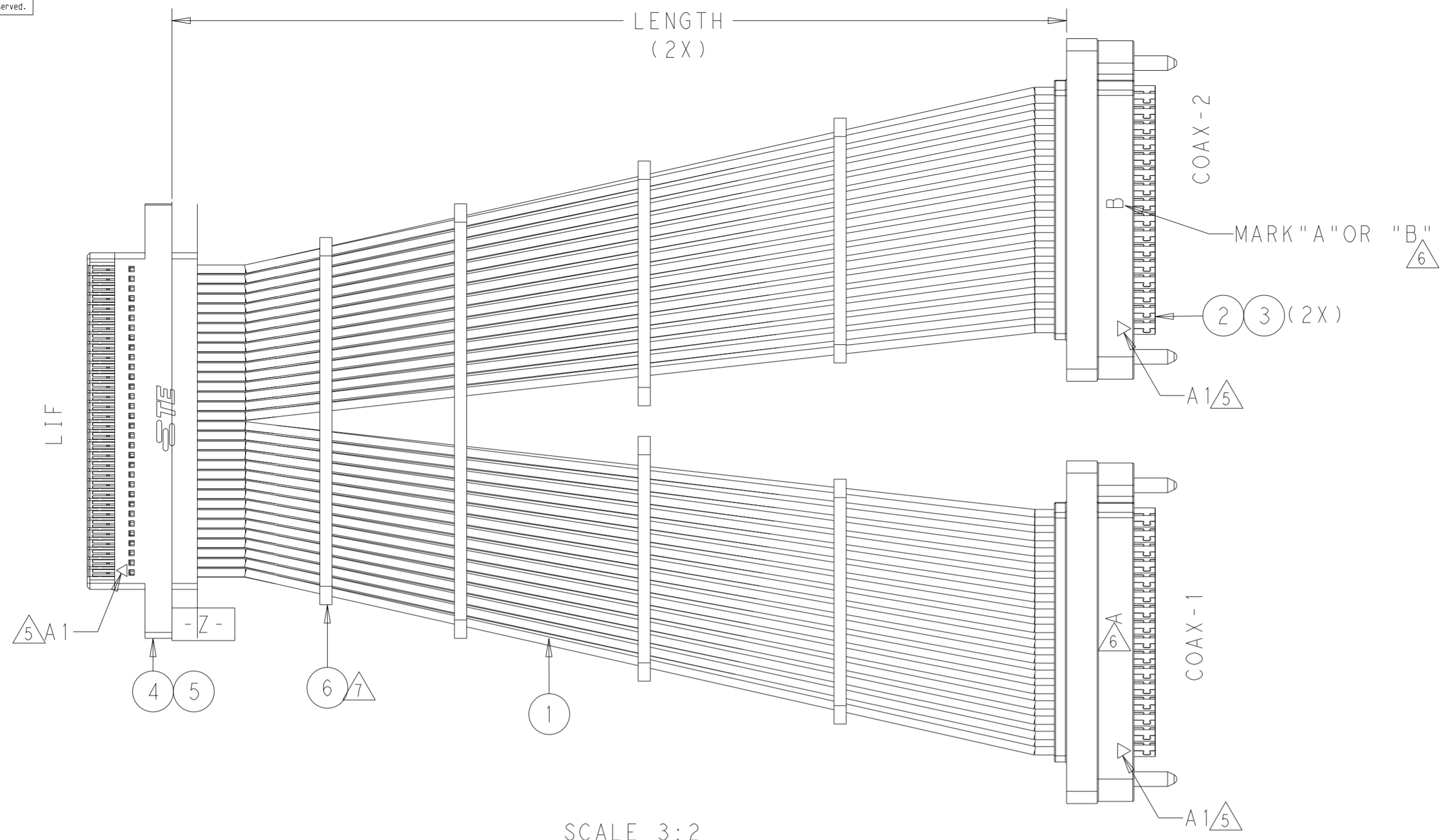

4 WIRING DIAGRAM

THIS PRINT IS
PRELIMINARY
 UNQUALIFIED PRODUCT
 CONTACT PRODUCT ENGINEERING
 BEFORE USING THIS PRINT

PART NUMBER	LENGTH
2016746-7	700±5
2016746-6	600±5
2016746-3	350±5
2016746-1	1000±5

Q'TY	UNIT	DESCRIPTION	ITEM
6	AR	PC CABLE TIE	6
5	128	PC LIF CONTACT	5
4	1	PC LIF CONN HOUSING, 128POS	4
3	128	PC COAX CONTACT	3
2	2	PC COAX CONN, HOUSING, 64POS	2
1	AR	MR COAX-CABLE, 1.15MM O.D, WHITE	1

- NOTES:
- MATERIAL AND PROCESSING MUST MEET REQUIREMENTS OF TEC-138-702
 - PRODUCT RATING:
 TEMPERATURE: -40°C TO +85°C
 VOLTAGE: 40V (RMS)
 BEND RADIUS: 5MM MIN(SINGAL CABLE)
 - CABLE ASSEMBLY TO BE 100% CONTINUITY, OPEN AND SHORT TEST
 HI-POT: 270V AC RMS
- 4 LIF PLUG TO COAX PLUG, 1 TO 1 PER WIRE LIST, NO MISS PIN, NO CROSS ON CABLE
 5 WIRING LIST FOLLOW PAGE 2, GROUNDING WILL NOT BE CONNECTED TOGETHER
 6 CONNECTOR PIN MAP REFER TO PN2081996 AND PN2386423 & PN2386424
 7 MARK "1" "2" ON EACH COAX CONNECTOR
 CABLE TIE WILL BE ABOUT PER 200MM 1PCS

THIS DRAWING IS A CONTROLLED DOCUMENT.

DWN 20-Jan-21
 Cedar Liu
 CHK 20JAN2021
 Cedar Liu
 APVD - NAME
 Wenke He

STE TE Connectivity

PRELIMINARY

LIF PLUG 128P TO 2 X 64P COAX PLUG
 POWER CA

SIZE CAGE CODE DRAWING NO RESTRICTED TO
 A2 00779 C-2016746

MATERIAL - FINISH - WEIGHT -
 finish_spec_2

APPLICATION SPEC -
 WEIGHT -

CUSTOMER DRAWING SCALE 1:1 SHEET 1 OF 4 REV 4

WIRING LIST $\triangle 5 \triangle 4$

P	LTR	DESCRIPTION	DATE	DWN	APVD

LIF to Coax1			LIF to Coax1			LIF to Coax1			LIF to Coax1			LIF to Coax2			LIF to Coax2			LIF to Coax2			LIF to Coax2		
LIF	COAX	Function	LIF	COAX	Function	LIF	COAX	Function	LIF	COAX	Function	LIF	COAX	Function	LIF	COAX	Function	LIF	COAX	Function	LIF	COAX	Function
A1	A2	G	B1	B1	S	C1	C1	G	D1	D2	S	A33	A2	G	B33	B1	S	C33	C1	G	D33	D2	S
A2	A1	S	B2	B2	G	C2	C2	S	D2	D1	G	A34	A1	S	B34	B2	G	C34	C2	S	D34	D1	G
A3	A4	G	B3	B3	S	C3	C3	G	D3	D4	S	A35	A4	G	B35	B3	S	C35	C3	G	D35	D4	S
A4	A3	S	B4	B4	G	C4	C4	S	D4	D3	G	A36	A3	S	B36	B4	G	C36	C4	S	D36	D3	G
A5	A6	G	B5	B5	S	C5	C5	G	D5	D6	S	A37	A6	G	B37	B5	S	C37	C5	G	D37	D6	S
A6	A5	S	B6	B6	G	C6	C6	S	D6	D5	G	A38	A5	S	B38	B6	G	C38	C6	S	D38	D5	G
A7	A8	G	B7	B7	S	C7	C7	G	D7	D8	S	A39	A8	G	B39	B7	S	C39	C7	G	D39	D8	S
A8	A7	S	B8	B8	G	C8	C8	S	D8	D7	G	A40	A7	S	B40	B8	G	C40	C8	S	D40	D7	G
A9	A10	G	B9	B9	S	C9	C9	G	D9	D10	S	A41	A10	G	B41	B9	S	C41	C9	G	D41	D10	S
A10	A9	S	B10	B10	G	C10	C10	S	D10	D9	G	A42	A9	S	B42	B10	G	C42	C10	S	D42	D9	G
A11	A12	G	B11	B11	S	C11	C11	G	D11	D12	S	A43	A12	G	B43	B11	S	C43	C11	G	D43	D12	S
A12	A11	S	B12	B12	G	C12	C12	S	D12	D11	G	A44	A11	S	B44	B12	G	C44	C12	S	D44	D11	G
A13	A14	G	B13	B13	S	C13	C13	G	D13	D14	S	A45	A14	G	B45	B13	S	C45	C13	G	D45	D14	S
A14	A13	S	B14	B14	G	C14	C14	S	D14	D13	G	A46	A13	S	B46	B14	G	C46	C14	S	D46	D13	G
A15	A16	G	B15	B15	S	C15	C15	G	D15	D16	S	A47	A16	G	B47	B15	S	C47	C15	G	D47	D16	S
A16	A15	S	B16	B16	G	C16	C16	S	D16	D15	G	A48	A15	S	B48	B16	G	C48	C16	S	D48	D15	G
A17	A18	G	B17	B17	S	C17	C17	G	D17	D18	S	A49	A18	G	B49	B17	S	C49	C17	G	D49	D18	S
A18	A17	S	B18	B18	G	C18	C18	S	D18	D17	G	A50	A17	S	B50	B18	G	C50	C18	S	D50	D17	G
A19	A20	G	B19	B19	S	C19	C19	G	D19	D20	S	A51	A20	G	B51	B19	S	C51	C19	G	D51	D20	S
A20	A19	S	B20	B20	G	C20	C20	S	D20	D19	G	A52	A19	S	B52	B20	G	C52	C20	S	D52	D19	G
A21	A22	G	B21	B21	S	C21	C21	G	D21	D22	S	A53	A22	G	B53	B21	S	C53	C21	G	D53	D22	S
A22	A21	S	B22	B22	G	C22	C22	S	D22	D21	G	A54	A21	S	B54	B22	G	C54	C22	S	D54	D21	G
A23	A24	G	B23	B23	S	C23	C23	G	D23	D24	S	A55	A24	G	B55	B23	S	C55	C23	G	D55	D24	S
A24	A23	S	B24	B24	G	C24	C24	S	D24	D23	G	A56	A23	S	B56	B24	G	C56	C24	S	D56	D23	G
A25	A26	G	B25	B25	S	C25	C25	G	D25	D26	S	A57	A26	G	B57	B25	S	C57	C25	G	D57	D26	S
A26	A25	S	B26	B26	G	C26	C26	S	D26	D25	G	A58	A25	S	B58	B26	G	C58	C26	S	D58	D25	G
A27	A28	G	B27	B27	S	C27	C27	G	D27	D28	S	A59	A28	G	B59	B27	S	C59	C27	G	D59	D28	S
A28	A27	S	B28	B28	G	C28	C28	S	D28	D27	G	A60	A27	S	B60	B28	G	C60	C28	S	D60	D27	G
A29	A30	G	B29	B29	S	C29	C29	G	D29	D30	S	A61	A30	G	B61	B29	S	C61	C29	G	D61	D30	S
A30	A29	S	B30	B30	G	C30	C30	S	D30	D29	G	A62	A29	S	B62	B30	G	C62	C30	S	D62	D29	G
A31	A32	G	B31	B31	S	C31	C31	G	D31	D32	S	A63	A32	G	B63	B31	S	C63	C31	G	D63	D32	S
A32	A31	S	B32	B32	G	C32	C32	S	D32	D31	G	A64	A31	S	B64	B32	G	C64	C32	S	D64	D31	G

Notes:
 1) "G" is grounding, "S" is signal

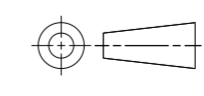
THIS DRAWING IS A CONTROLLED DOCUMENT.		DWN Cedar Liu 20-Jan-21	 TE Connectivity		
		CHK Cedar Liu 20 JAN 2021			
DIMENSIONS: mm		TOLERANCES UNLESS OTHERWISE SPECIFIED: 0 PLC ±- 1 PLC ±0.2 2 PLC ±0.13 3 PLC ±0.013 4 PLC ±0.0001 ANGLES ±- FINISH -		APVD Wenke He PRODUCT SPEC APPLICATION SPEC - WEIGHT - CUSTOMER DRAWING	
		NAME LIF PLUG 128P TO 2 X 64P COAX PLUG POWER CA SIZE A2 CAGE CODE 00779 DRAWING NO C-2016746 SCALE 1:1 SHEET 2 OF 4 REV 4		RESTRICTED TO -	

P	LTR	DESCRIPTION	DATE	DWN	APVD
-	-	SEE SHEET 1	-	-	-

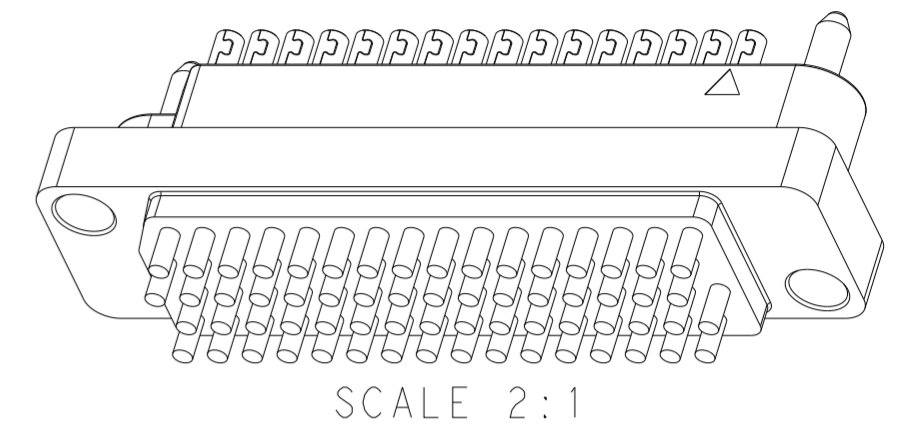
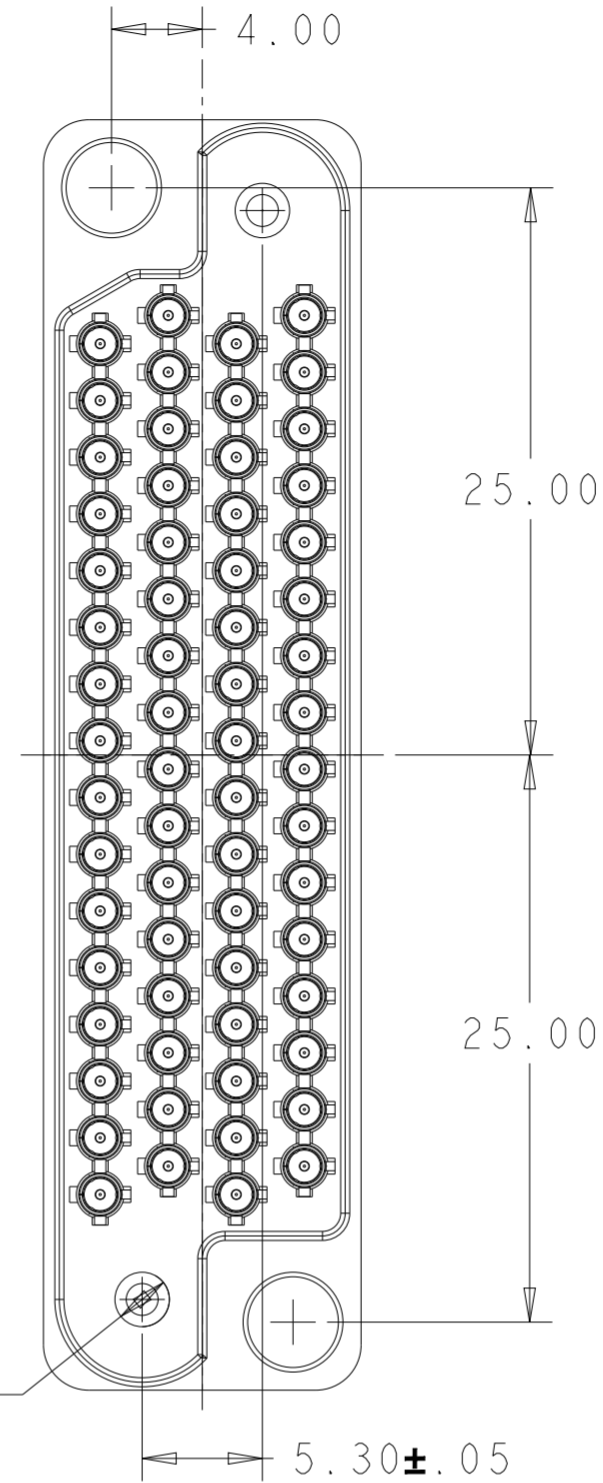
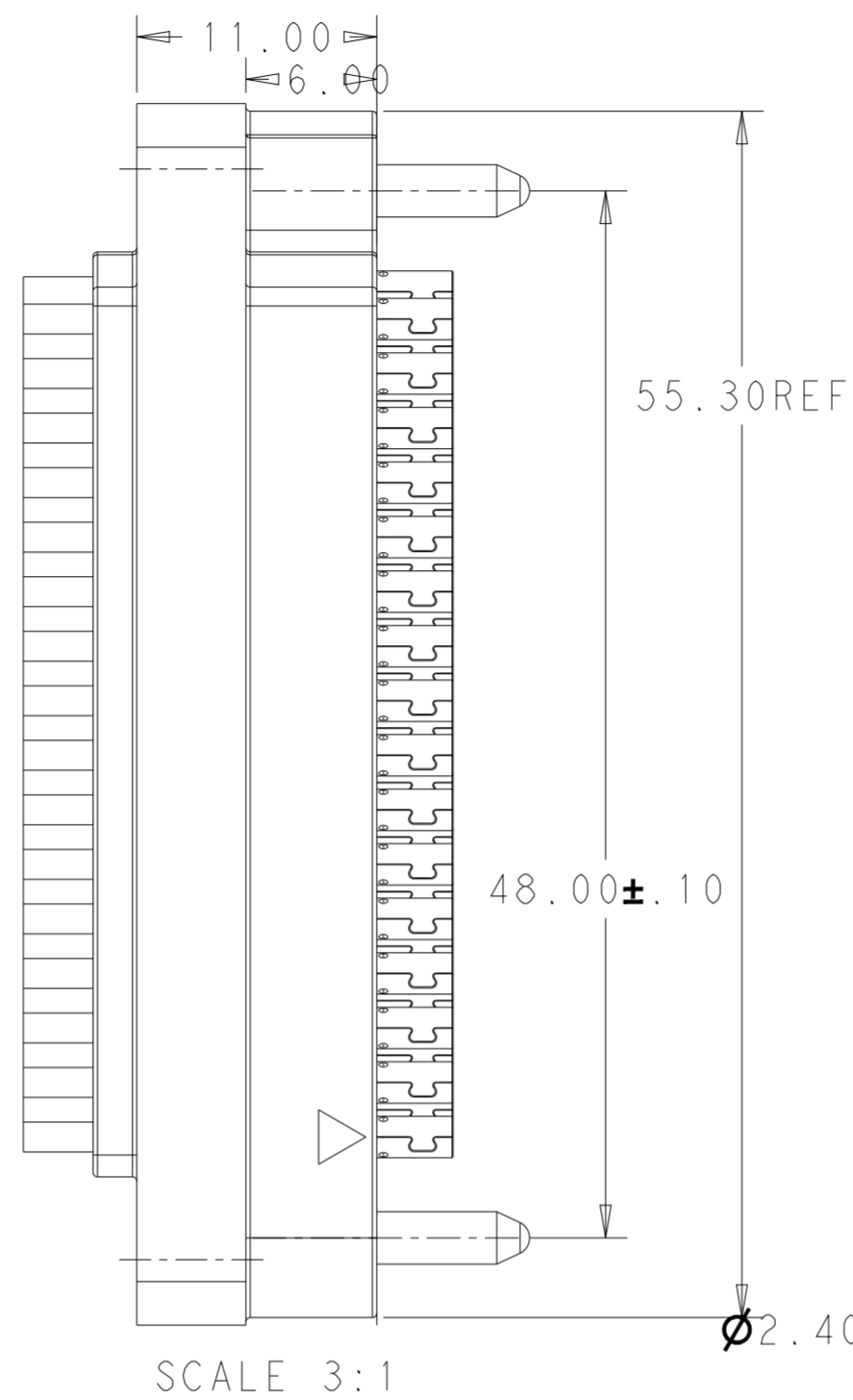
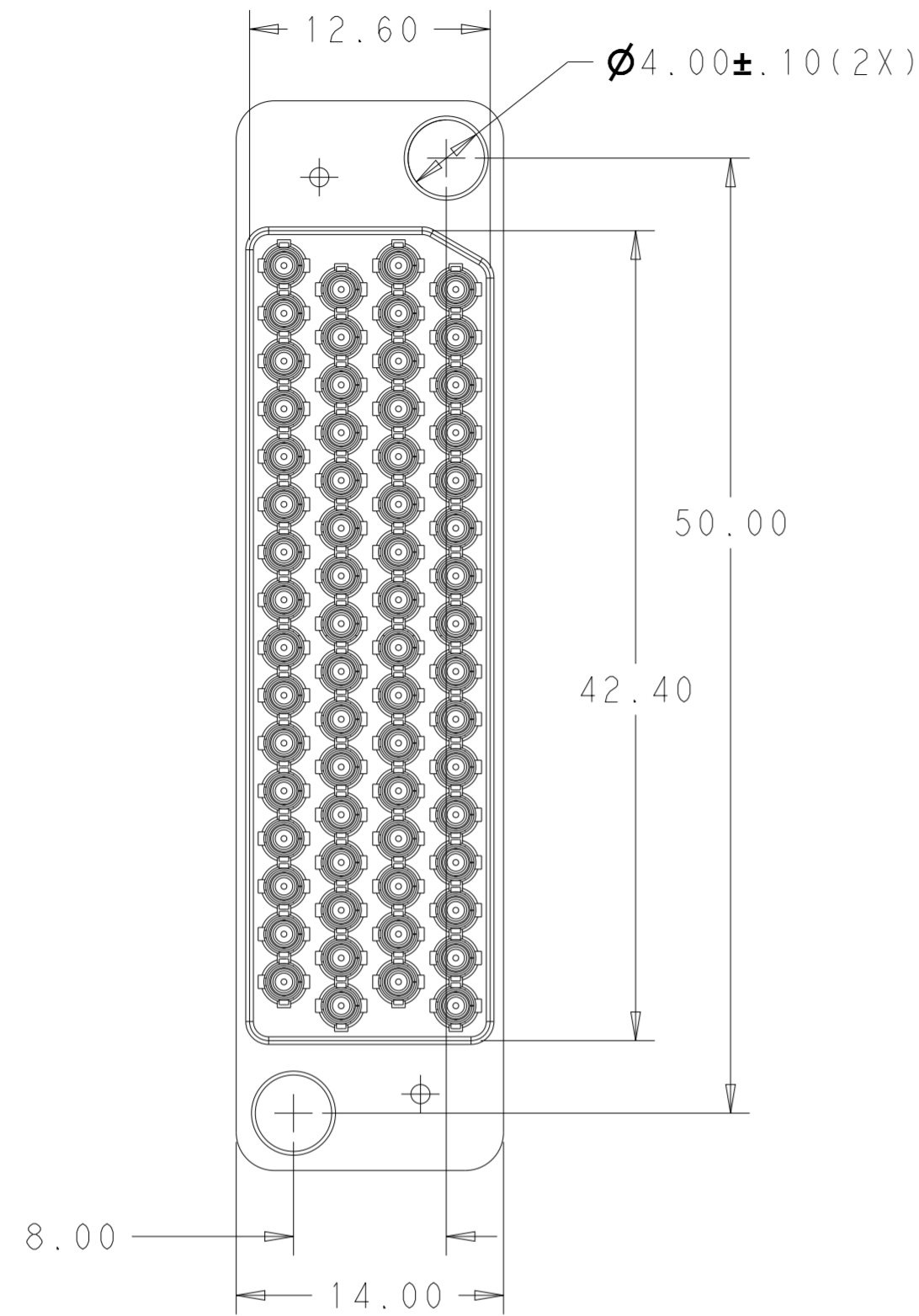

SEE DETAIL A

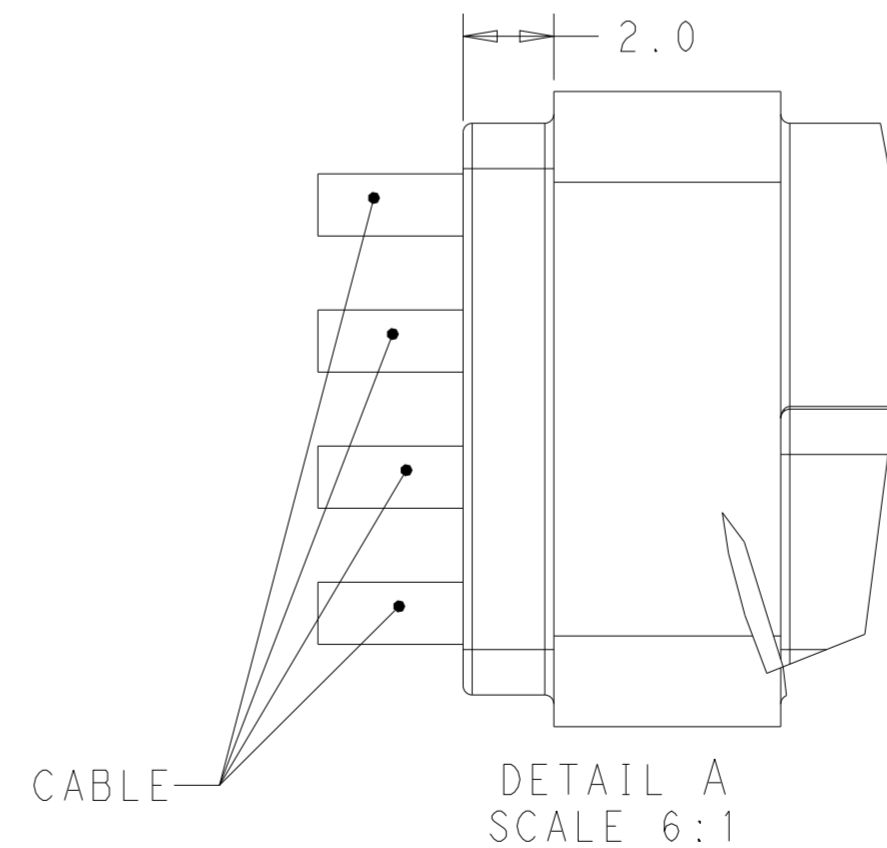
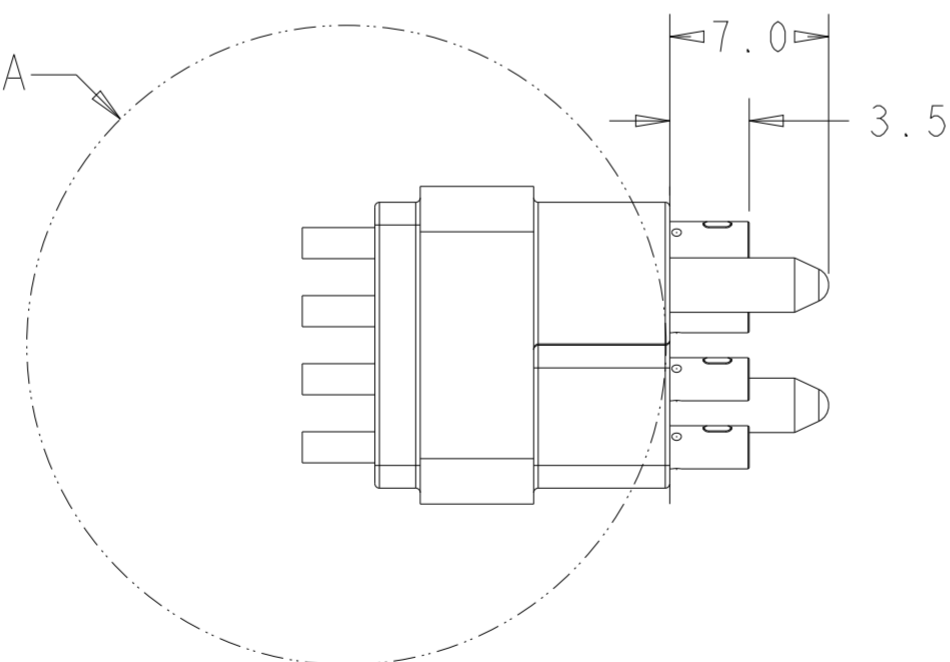

THIS PRINT IS
PRELIMINARY
 UNQUALIFIED PRODUCT
 CONTACT PRODUCT ENGINEERING
 BEFORE USING THIS PRINT

THIS DRAWING IS A CONTROLLED DOCUMENT.		DWN Cedar Liu 20-Jan-21	STE TE Connectivity	
		CHK Julia Zhu 20JAN2021		
DIMENSIONS: mm	TOLERANCES UNLESS OTHERWISE SPECIFIED:	APVD Wenke He	NAME LIF PLUG 128P TO 2 X 64P COAX PLUG POWER CA	
	0 PLC ± 2 1 PLC ± 5 2 PLC ± 13 3 PLC ± 0.13 4 PLC ± 0.001	PRODUCT SPEC -	SIZE A2	CAGE CODE 00779
MATERIAL -	FINISH -	APPLICATION SPEC -	DRAWING NO C-2016746	RESTRICTED TO -
	finish_spec_2	WEIGHT -	SCALE 1:1 SHEET 3 OF 4 REV 4	
		CUSTOMER DRAWING		

P	LTR	DESCRIPTION	DATE	DWN	APVD
-	-	SEE SHEET 1	-	-	-

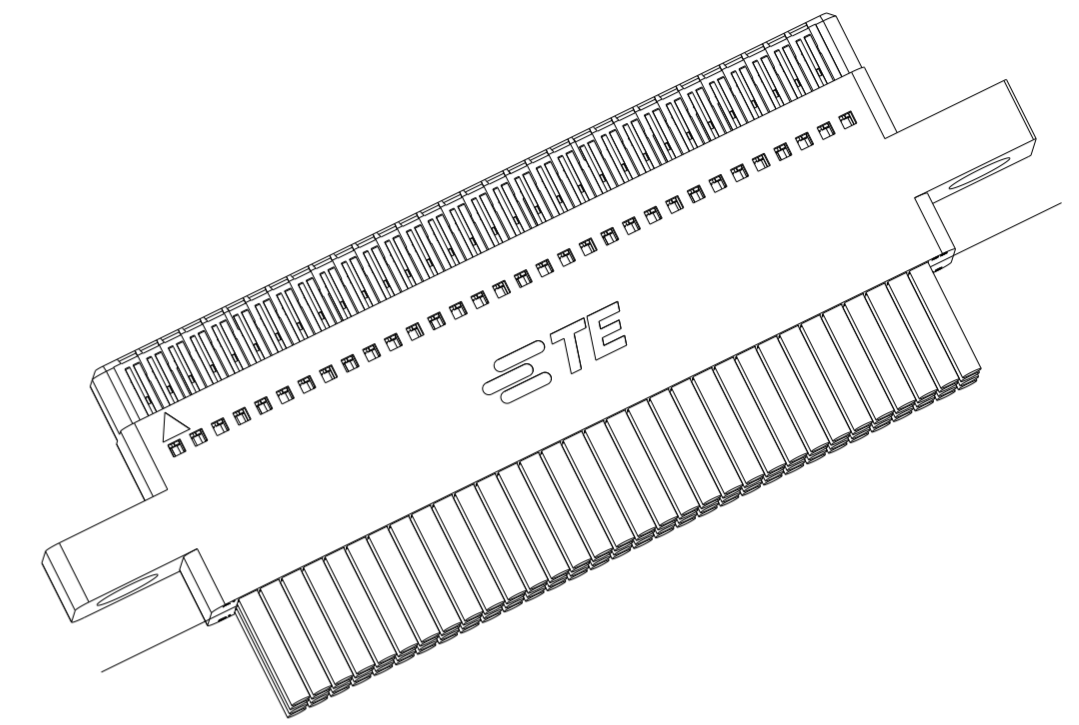
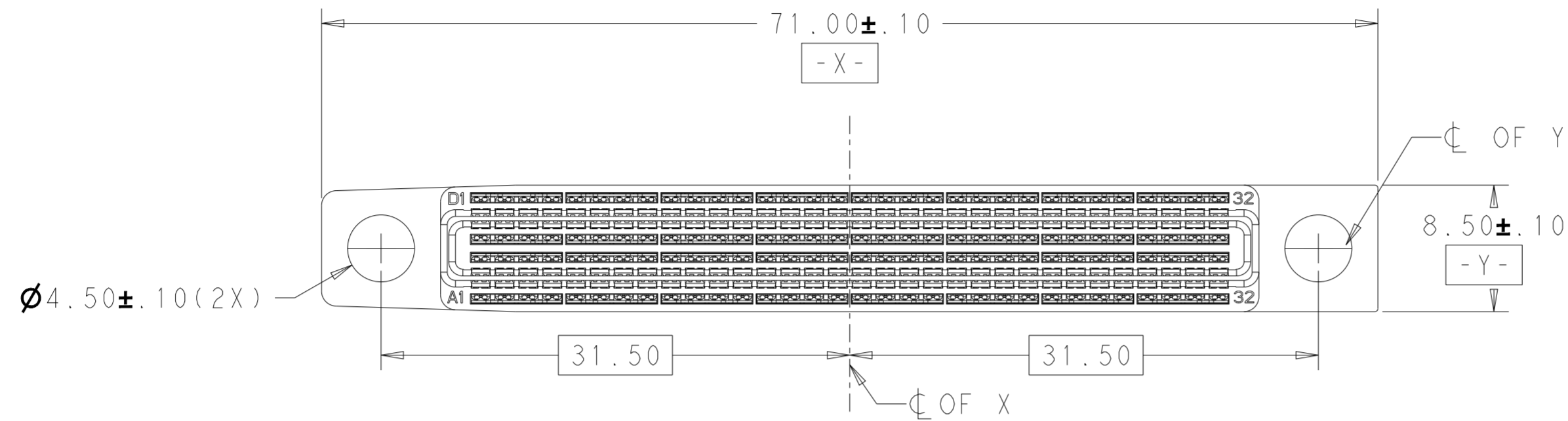

SCALE 2:1

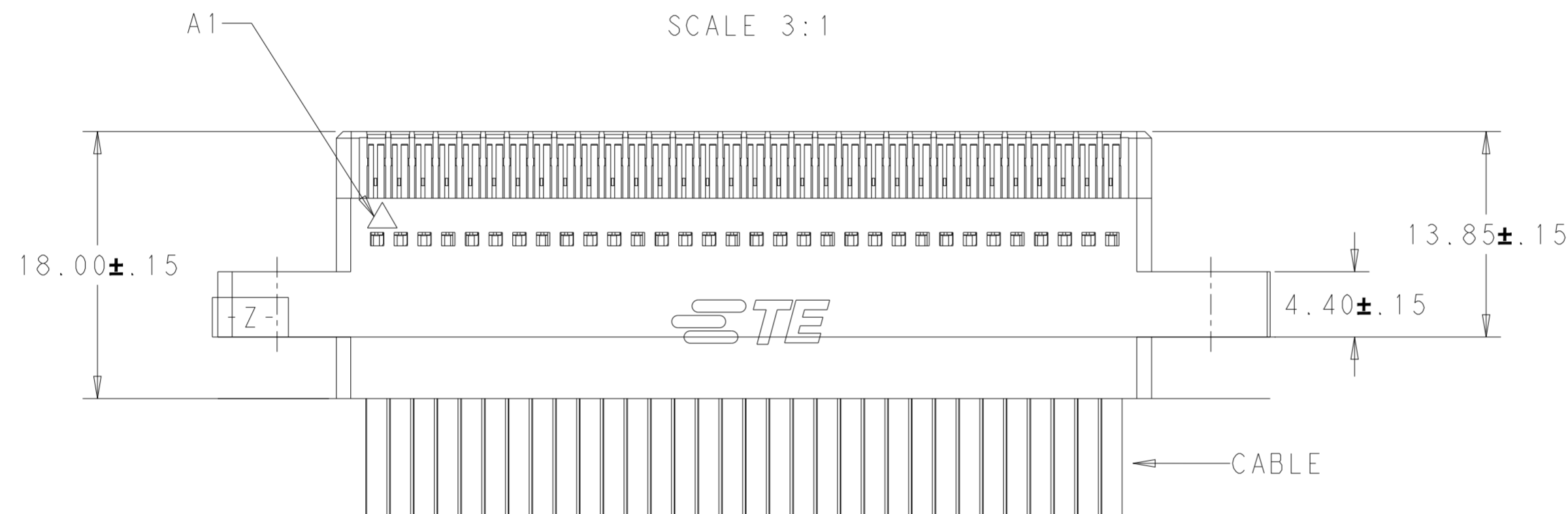

THIS PRINT IS
PRELIMINARY
 UNQUALIFIED PRODUCT
 CONTACT PRODUCT ENGINEERING
 BEFORE USING THIS PRINT

THIS DRAWING IS A CONTROLLED DOCUMENT.		DWN Cedar Liu 20-Jan-21	STE TE Connectivity	
		CHK Art Lin 20 JAN 2021		
DIMENSIONS: mm	TOLERANCES UNLESS OTHERWISE SPECIFIED:	APVD Wenke He	NAME LIF PLUG 128P TO 2 X 64P COAX PLUG POWER CA	
	0 PLC ±0.2 1 PLC ±0.2 2 PLC ±0.13 3 PLC ±0.013 4 PLC ±0.0001 ANGLES ±	PRODUCT SPEC -	SIZE A2	
MATERIAL -	FINISH -	APPLICATION SPEC -	CAGE CODE 00779	DRAWING NO C-2016746
	finish_spec_2	WEIGHT -	RESTRICTED TO -	
		CUSTOMER DRAWING	SCALE 1:1	SHEET 4 OF 4
				REV 4