

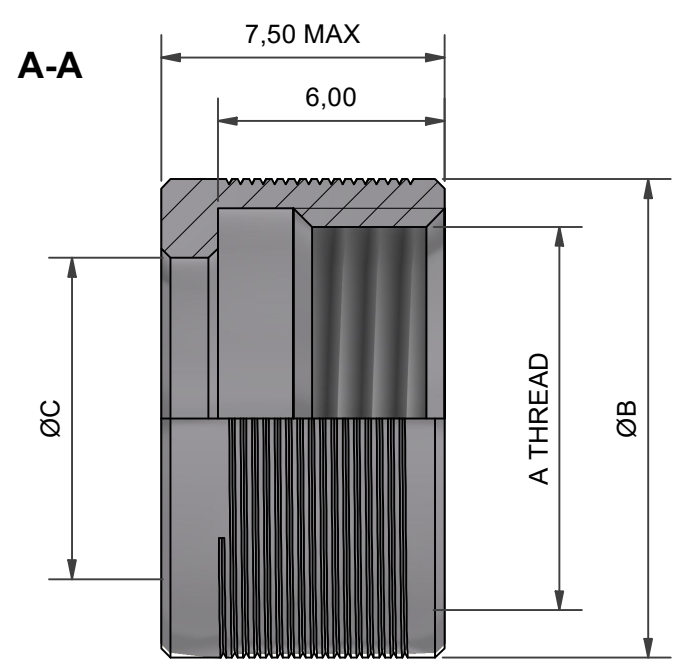

ISS / REV	DESCRIPTION	CHANGED BY	DATE
A	INITIAL RELEASE	K.K-W	02/07/15
B	CRN 26424	N.H	07/03/24

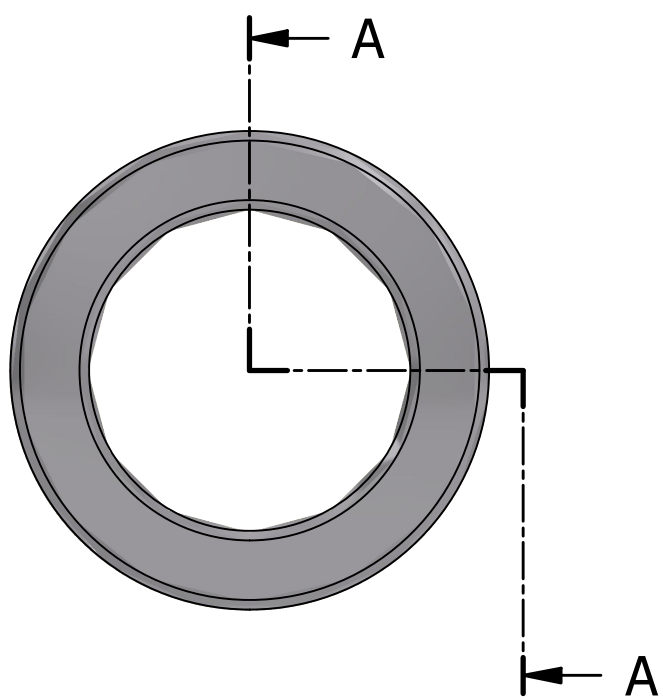
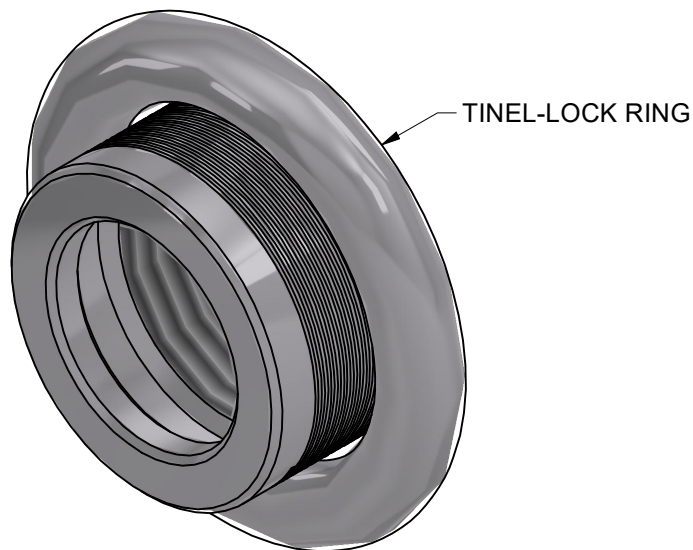

PART NUMBER	DRAWING NUMBER	ORDER NUMBER	ENTRY SIZE	ØA THREAD	ØB	ØC
200Z6340-*** TR06*I	200Z6340	08	06	7/16-28UNEF	12,66 ± 0,04	8,5
200Z6350-*** TR08*I	200Z6350	10	08	9/16-24UNEF	15,81 ± 0,07	11,5

200Z6340-19B TR06AI

DRAWING NUMBER _____
 200Z6340
 200Z6350
 MATERIAL _____
 REFER TO CH00-0250-004
 FINISH _____
 REFER TO CH00-0250-004
 TINEL-LOCK RING _____
 RING SIZE _____
 RING OPTION _____
 AI - TO SUIT SINGLE BRAID
 BI - TO SUIT SINGLE BRAID

<table border="1"> <tr> <td>ISSUE/REV</td> <td>CRN</td> </tr> <tr> <td>B</td> <td>26424</td> </tr> </table>	ISSUE/REV	CRN	B	26424	<table border="1"> <tr> <td>DATE</td> <td>02/07/2015</td> </tr> <tr> <td>SALES APPR</td> <td>M.PAUL</td> </tr> <tr> <td>DESIGN APPR</td> <td>K.SHEPPARD</td> </tr> <tr> <td>PROD APPR</td> <td>K.SMITH</td> </tr> <tr> <td>QUAL APPR</td> <td>P.REES</td> </tr> </table>	DATE	02/07/2015	SALES APPR	M.PAUL	DESIGN APPR	K.SHEPPARD	PROD APPR	K.SMITH	QUAL APPR	P.REES	<table border="1"> <tr> <td>3RD ANGLE PROJECTION NOT TO SCALE</td> </tr> <tr> <td>UNLESS OTHERWISE SPECIFIED ALL DIMENSIONS IN MILLIMETRES GENERAL TOL LINEAR +/-0,25MM ANGULAR +/- 1°</td> </tr> <tr> <td>MATERIAL SEE PART NUMBER BREAKDOWN</td> </tr> <tr> <td>FINISH SEE PART NUMBER BREAKDOWN</td> </tr> </table>	3RD ANGLE PROJECTION NOT TO SCALE	UNLESS OTHERWISE SPECIFIED ALL DIMENSIONS IN MILLIMETRES GENERAL TOL LINEAR +/-0,25MM ANGULAR +/- 1°	MATERIAL SEE PART NUMBER BREAKDOWN	FINISH SEE PART NUMBER BREAKDOWN	<table border="1"> <tr> <td>PART NUMBER: 200Z63XX-XXX TRXXXI</td> </tr> <tr> <td>TITLE: TINEL-LOCK RING ADAPTOR</td> </tr> <tr> <td>ASSY USED ON: THIS DRAWING IS COPYRIGHT AND THE PROPERTY OF POLAMCO LTD IT MUST NOT BE COPIED, USED FOR MANUFACTURE OR OTHERWISE DISCLOSED WITHOUT PRIOR WRITTEN CONSENT OF THE COMPANY.</td> </tr> </table>	PART NUMBER: 200Z63XX-XXX TRXXXI	TITLE: TINEL-LOCK RING ADAPTOR	ASSY USED ON: THIS DRAWING IS COPYRIGHT AND THE PROPERTY OF POLAMCO LTD IT MUST NOT BE COPIED, USED FOR MANUFACTURE OR OTHERWISE DISCLOSED WITHOUT PRIOR WRITTEN CONSENT OF THE COMPANY.	 POLAMCO
ISSUE/REV	CRN																								
B	26424																								
DATE	02/07/2015																								
SALES APPR	M.PAUL																								
DESIGN APPR	K.SHEPPARD																								
PROD APPR	K.SMITH																								
QUAL APPR	P.REES																								
3RD ANGLE PROJECTION NOT TO SCALE																									
UNLESS OTHERWISE SPECIFIED ALL DIMENSIONS IN MILLIMETRES GENERAL TOL LINEAR +/-0,25MM ANGULAR +/- 1°																									
MATERIAL SEE PART NUMBER BREAKDOWN																									
FINISH SEE PART NUMBER BREAKDOWN																									
PART NUMBER: 200Z63XX-XXX TRXXXI																									
TITLE: TINEL-LOCK RING ADAPTOR																									
ASSY USED ON: THIS DRAWING IS COPYRIGHT AND THE PROPERTY OF POLAMCO LTD IT MUST NOT BE COPIED, USED FOR MANUFACTURE OR OTHERWISE DISCLOSED WITHOUT PRIOR WRITTEN CONSENT OF THE COMPANY.																									
NCAGE CODE 06090	WEIGHT ---	<table border="1"> <tr> <td>POLAMCO LTD, WESTON LOCK, LOWER BRISTOL ROAD BATH BA2 1EP</td> <td>SHT 1</td> <td>DRAWING NO: 200Z63XX-XXX TRXXXI</td> </tr> </table>	POLAMCO LTD, WESTON LOCK, LOWER BRISTOL ROAD BATH BA2 1EP	SHT 1	DRAWING NO: 200Z63XX-XXX TRXXXI																				
POLAMCO LTD, WESTON LOCK, LOWER BRISTOL ROAD BATH BA2 1EP	SHT 1	DRAWING NO: 200Z63XX-XXX TRXXXI																							