

REVISIONS			
P	LTR	DESCRIPTION	DATE
C		FOR-20-005312	10APR2020
			WZ
			WY

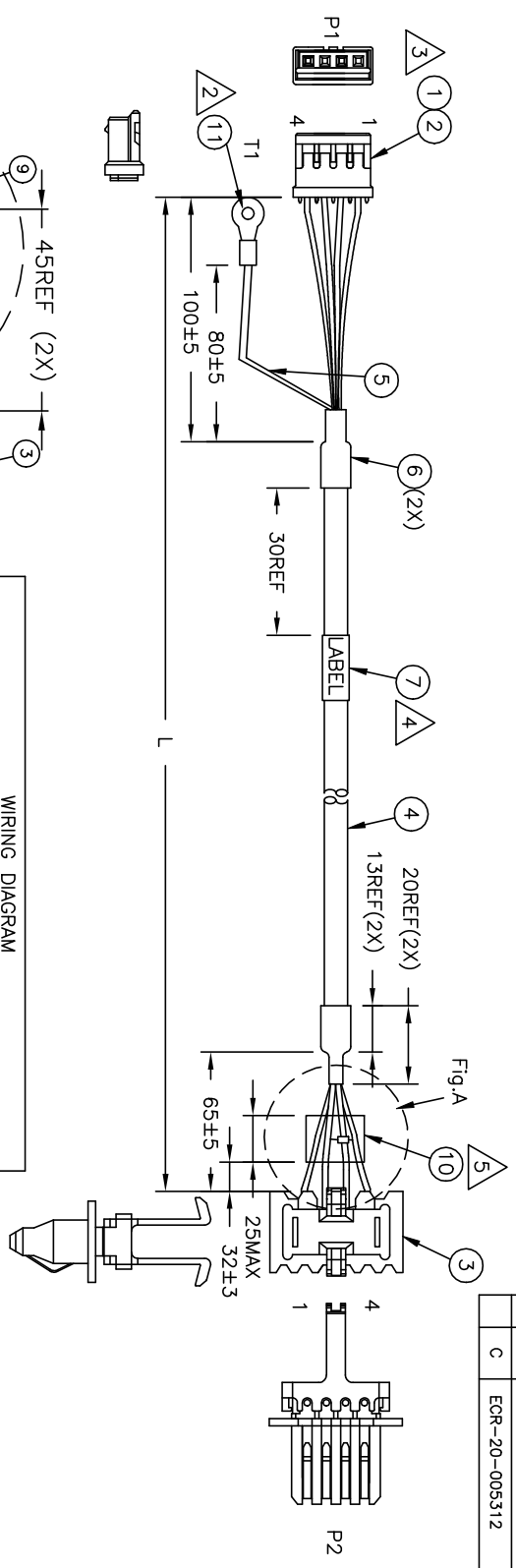

WIRING DIAGRAM			
FROM	WIRE COLOR	TO	
P1-1	BROWN	P2-1	
P1-2	BROWN/WHITE	P2-2	
P1-3	BLACK	P2-3	
P1-4	TWIST PAIR 2	P2-4	
T1	BLACK/WHITE	NC	

1	PC	RING TERMINAL 26~22AWG WIRE, M4 TYPE. KST:DRNYB4-0.5	11
AR	MR	HEAT SHRINK TUBE, ID: 5MM, COLOR: BLACK	10
AR	MR	HEAT SHRINK TUBE, ID: 1.5MM, COLOR: BLACK	9
1	PC	CAPACITOR, 1uF KEMET:C420C105K3R5T1	8
1	PC	LABEL, 25*50MM, WHITE: 25*13MM	7
AR	MR	HEAT SHRINK TUBE, ID: 6.0MM, COLOR: BLACK	6
AR	MR	HEAT SHRINK TUBE, ID: 1.0MM, COLOR: BLACK	5
AR	MR	CABLE, UL2464, 28AWG*2P+AL/MYLAR+DRAIN+BRAID, BLACK	4
1	PC	INK SUPPLY CONNECTOR, 1.735588-1, 4 POS., FOR WIRE 28AWG	3
4	PC	TERMINAL, FOR WIRE 24~30AWG, OD: 1.15MM, TIN-PLATED	2
1	PC	HOUSING, 1.5MM PITCH, 1*4 POS., NATURAL	1

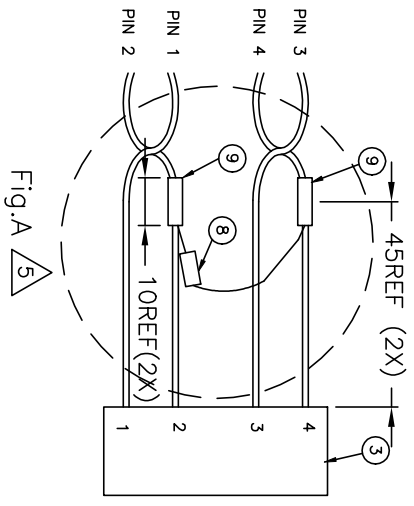

NOTES:

- PRODUCT AND PROCESSING MUST MEET REQUIREMENTS OF TEC-138-702.
- TWISTING DRAIN WIRE AND BRAID TOGETHER TO CRIMP RING TERMINAL (ITEM 11).
- APPLICATION SPECIFICATION: 114-57018.
- LABEL SHOULD BE MARKED AS BELOW:

CUSTOMER P/N REV *
TE YWWW
PRODUCT OF *****

COUNTRY OF ORIGIN

"0" IS ZERO IN CUSTOMER P/N

- CAPACITOR SHOULD BE COVERED WITH HST(L:12MM REF)
- CAPACITOR CAN BE REPLACED BY 2-1760204-5

THIS DRAWING IS A CONTROLLED DOCUMENT.

DIMENSIONS:	TOLERANCES UNLESS OTHERWISE SPECIFIED:
mm	
0	PLC
1	PLC
2	PLC
3	PLC
4	PLC
	ANGLES
	FINISH



TE Connectivity

MOBY ACUMEN CABLE

APD	NAME	SIZE	PAGE CODE	DRAWING NO	RESTRICTED TO
APD	Henry Kogy Hean Boon	A3	00779	2009090	
	Product spec				
	Application spec				
	Weight				

CUSTOMER DRAWING

SCALE: N.T.S. SHEET 1 OF 1 REV C