

REVISIONS					
P	LTR	DESCRIPTION	DATE	DWN	APVD
A1		REVISED(ECR-21-111218)	24AUG2021	EW	YD.

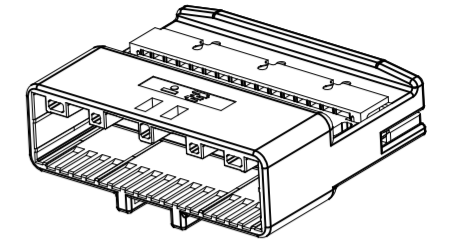

ISO VIEW  
SCALE  
1/1

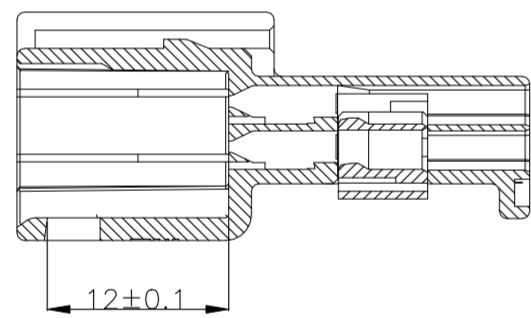
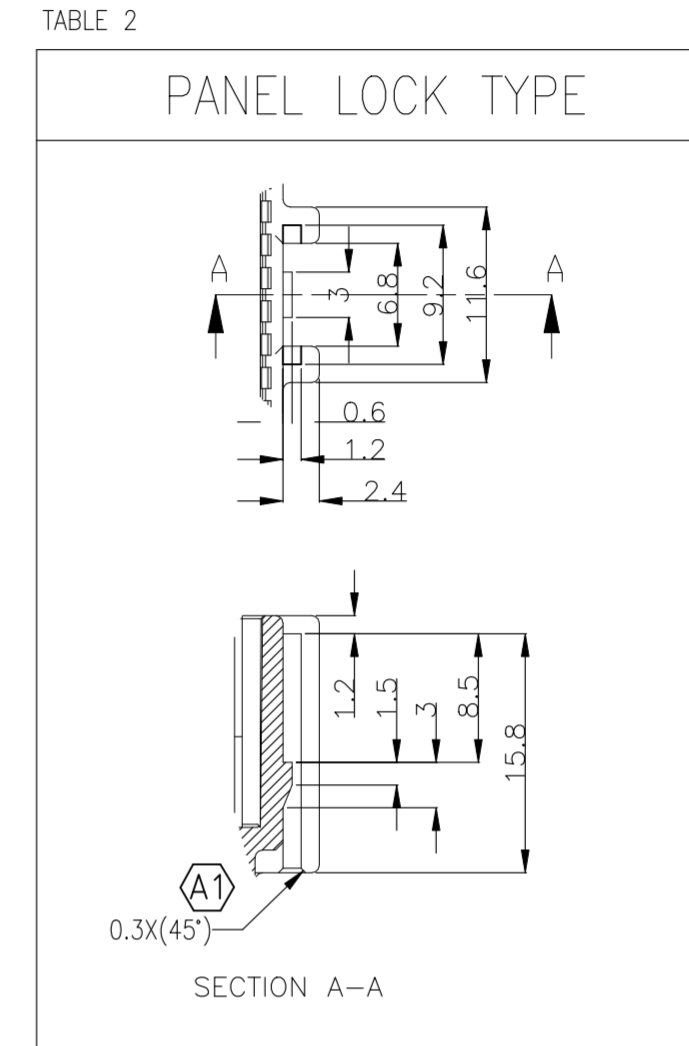
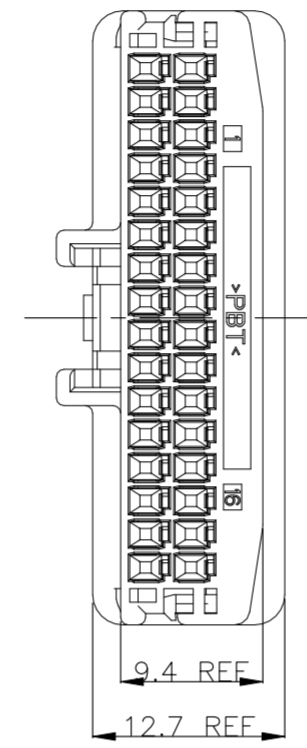
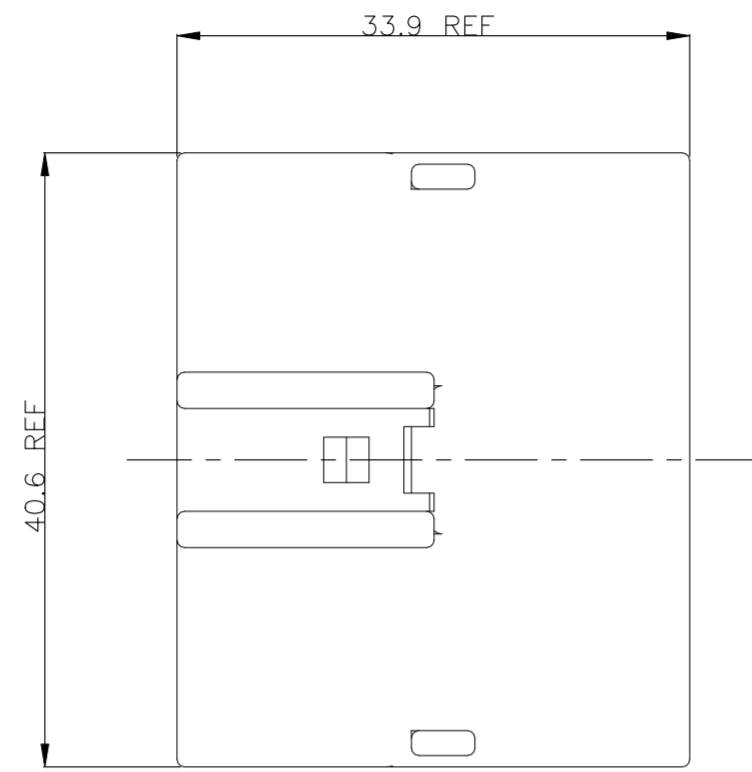
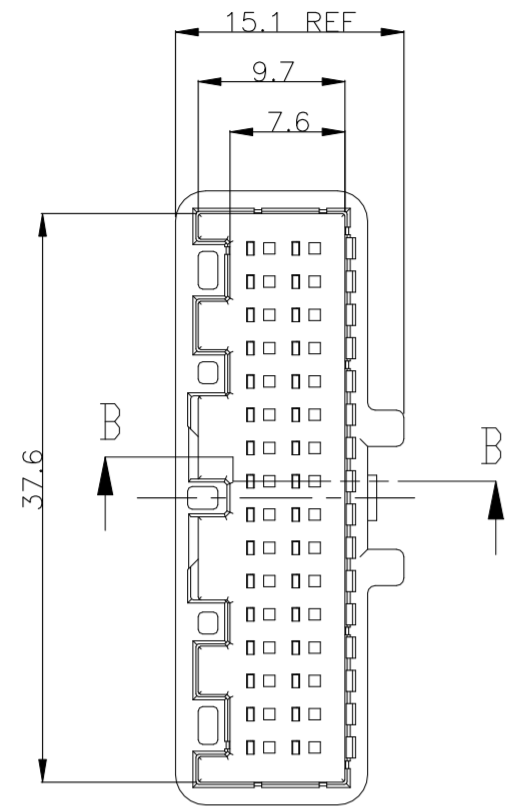

SECTION B-B

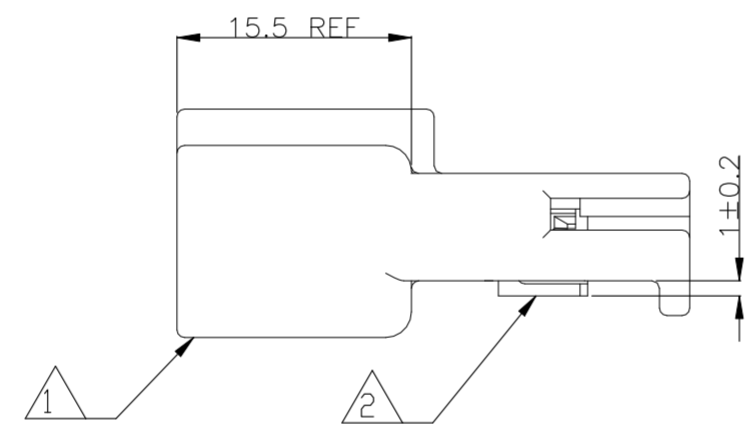

NOTE

1. DBL MUST BE SET TO THE PRE-ASSEMBLY POSITION WITHIN THE CAP HOUSING WHEN SHIPPED TO THE CUSTOMER.
2. DBL MUST BE OUT SIDE OF CAP HOUSING AT PRE-ASSEMBLY.
3. PART NUMBER OF PLUG HOUSING TO BE MATED : 2005088
4. APPLICABLE TERMINAL : TABLE 1
5. PANEL LOCK VARIATIONS : REFFER TO TABLE 2

TABLE 1

P/NO	FINISH	WIRE RANGE
2005098-1	PRE-TIN	CHFUS 0.13~0.22sq
2005154-1	PRE-TIN	AVSS 0.3~0.5sq

CAP ASSY DESCRIPTION	2005091-1 ASSY P/N

NO.	DESCRIPTION	FINISH/COLOR	Q'TY
2	DBL HSG	NATURAL	1
1	CAP HSG	NATURAL	1

THIS DRAWING IS A CONTROLLED DOCUMENT.		DWN YD. LEE	TE Connectivity 025 32P CAP ASSY																			
DIMENSIONS: mm		CHK YM CHOI																				
TOLERANCES UNLESS OTHERWISE SPECIFIED: $\pm 0.3, \pm 3$		APVD HG CHO	NAME																			
<table border="1"> <tr><td>0 PLC</td><td>±</td><td>-</td></tr> <tr><td>1 PLC</td><td>±</td><td>-</td></tr> <tr><td>2 PLC</td><td>±</td><td>-</td></tr> <tr><td>3 PLC</td><td>±</td><td>-</td></tr> <tr><td>4 PLC</td><td>±</td><td>-</td></tr> <tr><td>ANGLES</td><td>±</td><td>-</td></tr> </table>		0 PLC	±	-	1 PLC	±	-	2 PLC	±	-	3 PLC	±	-	4 PLC	±	-	ANGLES	±	-	PRODUCT SPEC	DRAWING NO	
0 PLC	±	-																				
1 PLC	±	-																				
2 PLC	±	-																				
3 PLC	±	-																				
4 PLC	±	-																				
ANGLES	±	-																				
MATERIAL PBT		FINISH	SIZE A2	CAGE CODE 00779																		
		WEIGHT	DRAWING NO C=2005091																			
		CUSTOMER DRAWING	SCALE 1:1	SHEET 1 OF 1																		
			RESTRICTED TO	REV A1																		