

REVISIONS

REV	DESCRIPTION	DATE	DWN	APVD
A	INITIAL RELEASE PER ECD 12171	06/11/2020	LH	JP
A1	MODIFY PER ECN-22-145197	23/03/2022	LH	RC

MATERIAL

HOUSING MATERIAL GLASS FILLED NYLON 6.6

FLOAT MATERIAL GLASS FILLED NYLON 6.6

INTERNAL FITTING

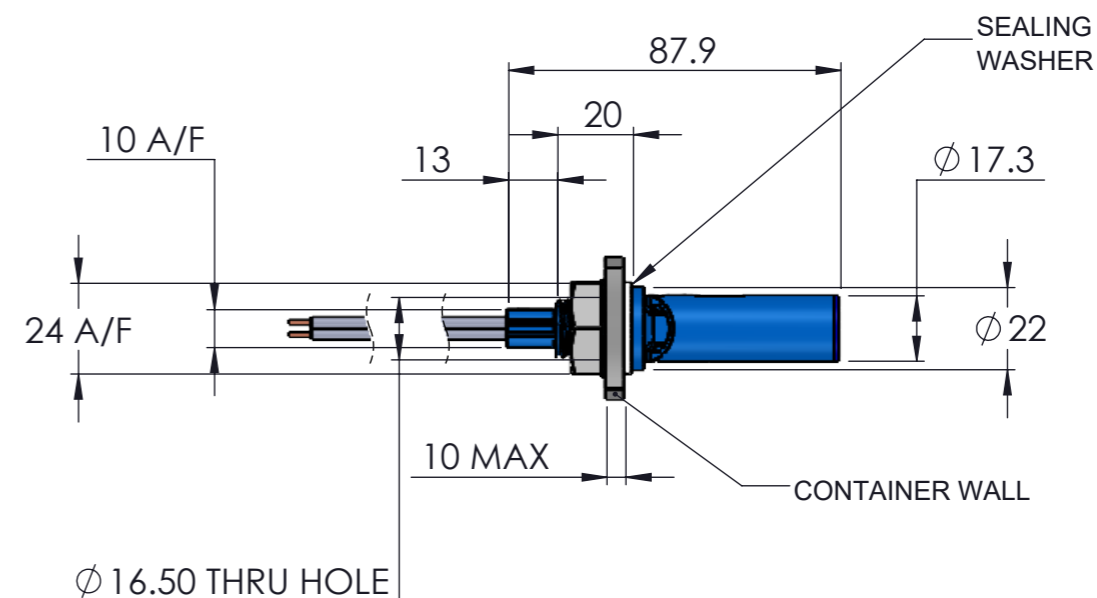
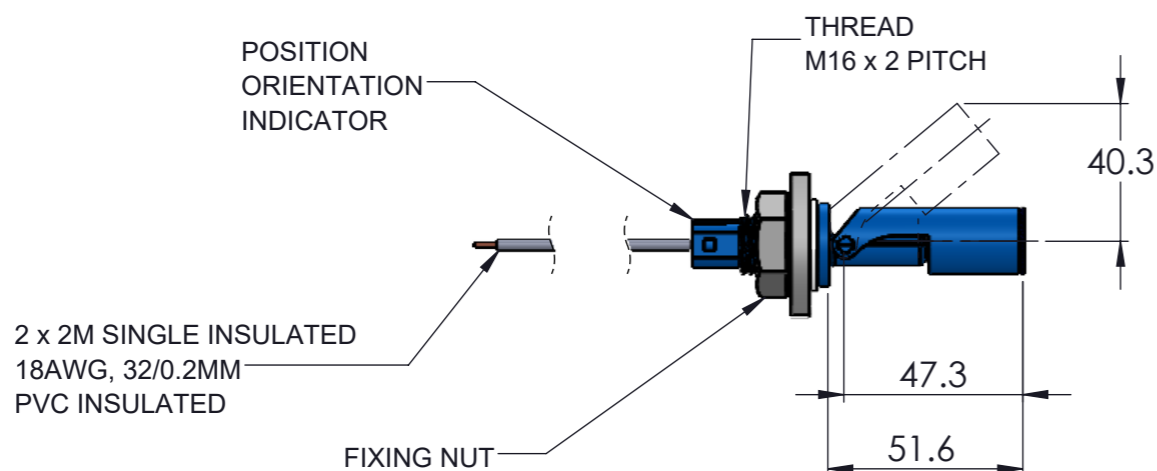

EXTERNAL FITTING

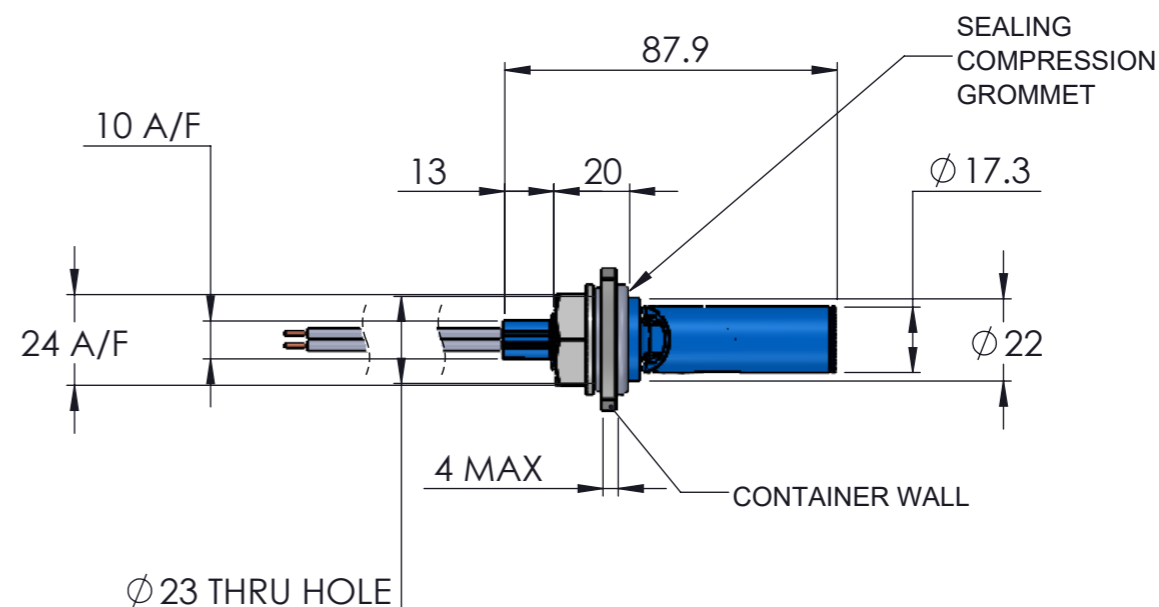
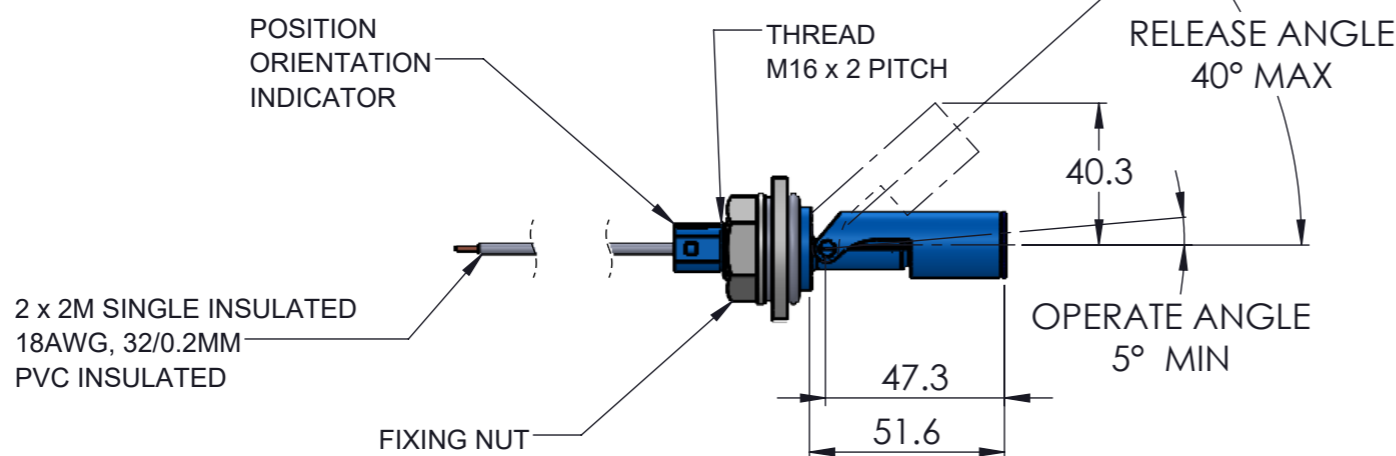

SWITCH CLOSED WITH FLOAT IN HORIZONTAL POSITION: FUNCTION OF DEVICE (NO/NC) CAN BE ALTERNATED WITH INSTALLATION OF POSITION INDICATOR UP/DOWN

THIS DRAWING IS A CONTROLLED DOCUMENT.		DWN L HERNANDEZ 06/11/2020	 TE Connectivity											
DIMENSIONS: mm		CHK R COOPER 06/11/2020												
TOLERANCES UNLESS OTHERWISE SPECIFIED:		APVD J PENDLETON 19/11/2020												
<table border="1"> <tr><td>0 PLC</td><td>±</td></tr> <tr><td>1 PLC</td><td>±0.5</td></tr> <tr><td>2 PLC</td><td>±0.13</td></tr> <tr><td>3 PLC</td><td>±0.013</td></tr> <tr><td>4 PLC</td><td>±0.0001</td></tr> <tr><td>ANGLES</td><td>±°</td></tr> </table>		0 PLC			±	1 PLC	±0.5	2 PLC	±0.13	3 PLC	±0.013	4 PLC	±0.0001	ANGLES
0 PLC	±													
1 PLC	±0.5													
2 PLC	±0.13													
3 PLC	±0.013													
4 PLC	±0.0001													
ANGLES	±°													
MATERIAL		FINISH	APPLICATION SPEC	NAME LS309-52 LIQUID LEVEL SENSOR										
			WEIGHT	SIZE A3										
				CAGE CODE 00779										
				DRAWING NO C=20017785-00										
				RESTRICTED TO										
				SCALE 1:2										
				SHEET 1 OF 1										
				REV A1										
				CUSTOMER DRAWING										