

REVISIONS					
P.	LTN	DESCRIPTION	DATE	DMN	APVD
1		PROPOSED DESIGN	19OCT2016	CZ	SZ

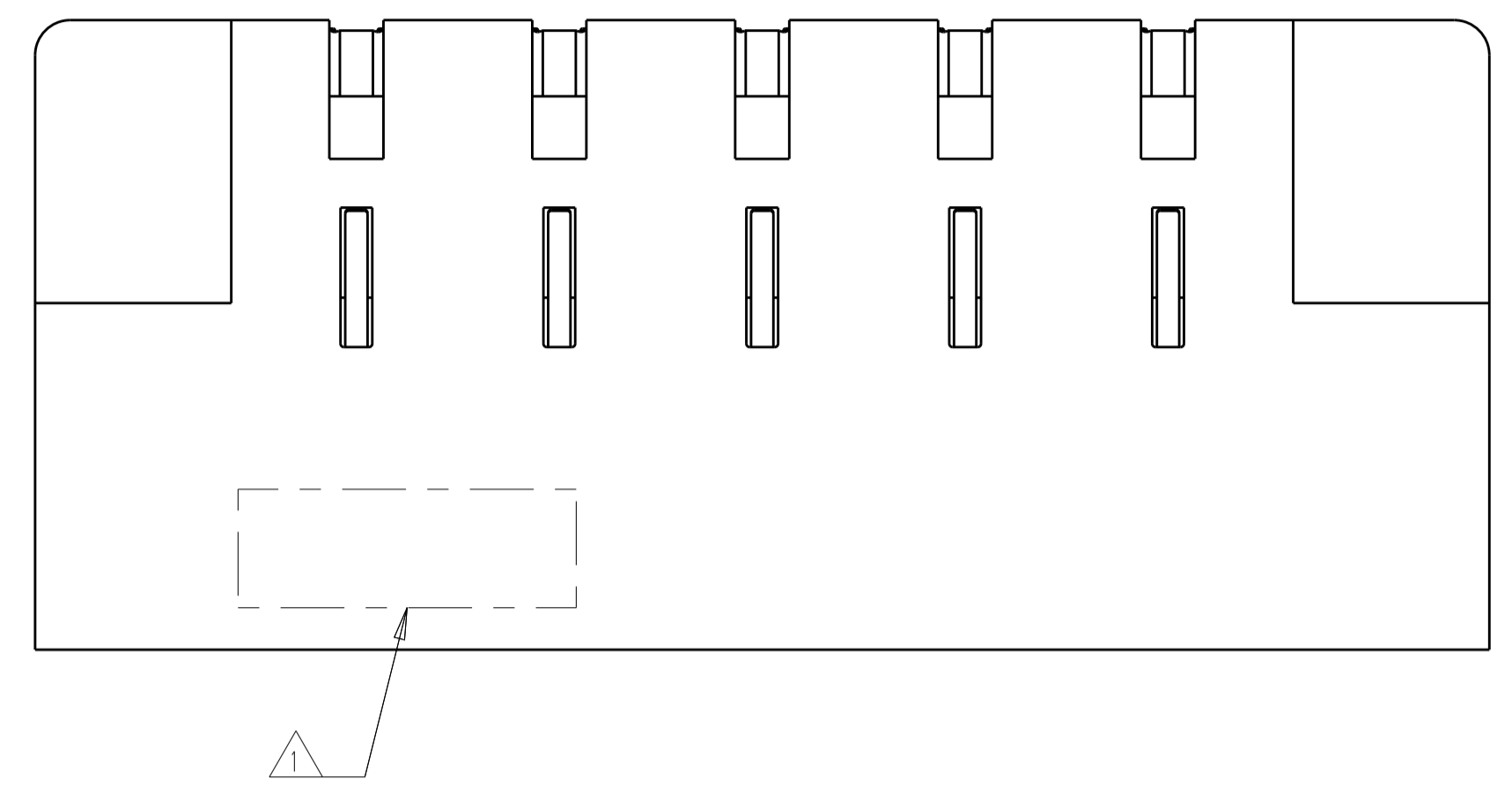

- 1 "AMP", PART NUMBER, AND DATECODE TO BE MARKED IN AREA SHOWN. PARTS UNDER 2.00 LONG MAY BE MARKED ON BOTH SIDES.
- 2 MATERIAL:
HOUSING - GLASS FILLED HIGH TEMP THERMO PLASTIC, BLACK, UL94 V-0
SIGNAL CONTACT - COPPER ALLOY
POWER CONTACT - HIGH CONDUCTIVITY COPPER ALLOY
- 3 CONTACT PLATING: NOBLE METAL PLATING ON CONTACT FUNCTIONAL AREA OF POWER AND SIGNAL CONTACTS.
- 4 MECHANICAL CONNECTOR KEEP OUT ZONE.
- 5 DATUM AND BASIC DIMENSIONS ESTABLISHED BY CUSTOMER.
- 6 PCB - HOLE DIAMETERS ARE FINISHED HOLE SIZE.
- 7 PCB - .0453±.0010 DRILLED HOLES PLATED WITH .0003 MIN Sn OVER .001 TO .003 Cu PLATING TO ACHIEVE A .040 ±.003 HOLE.

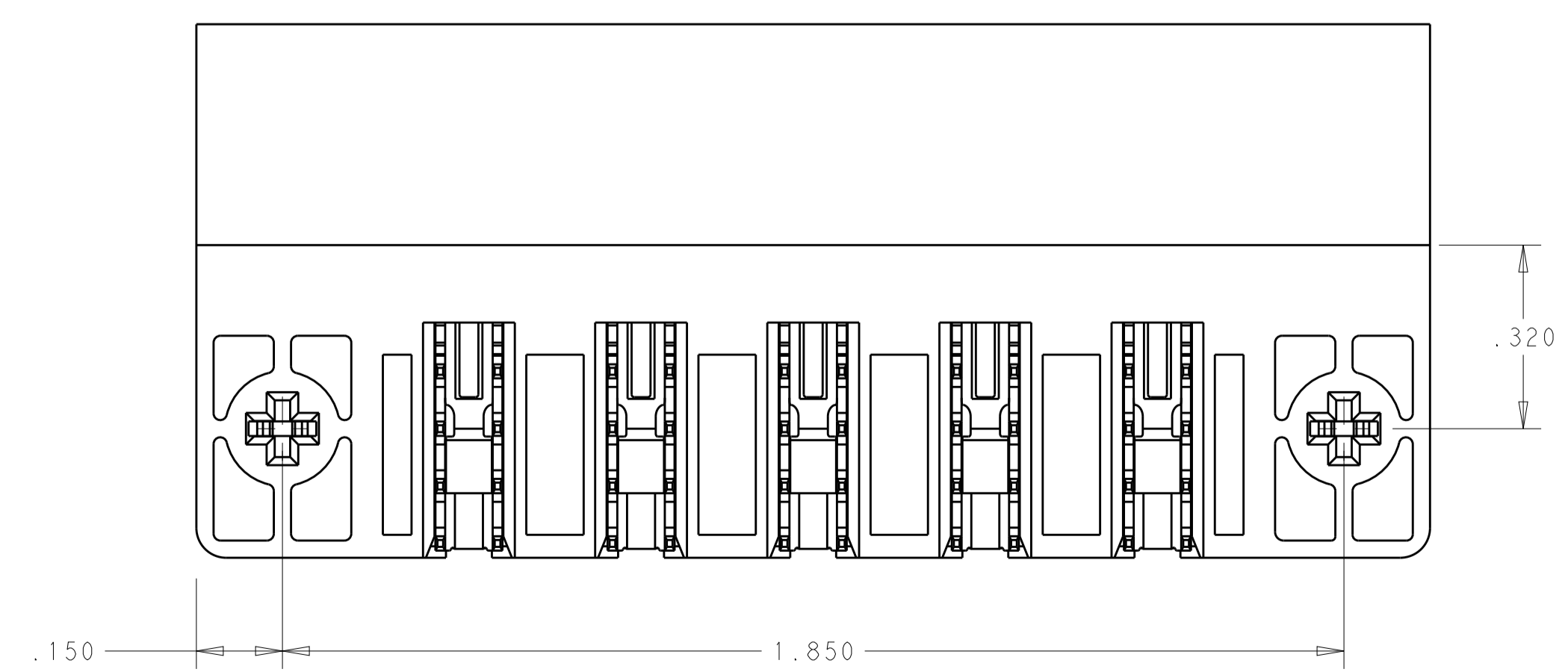
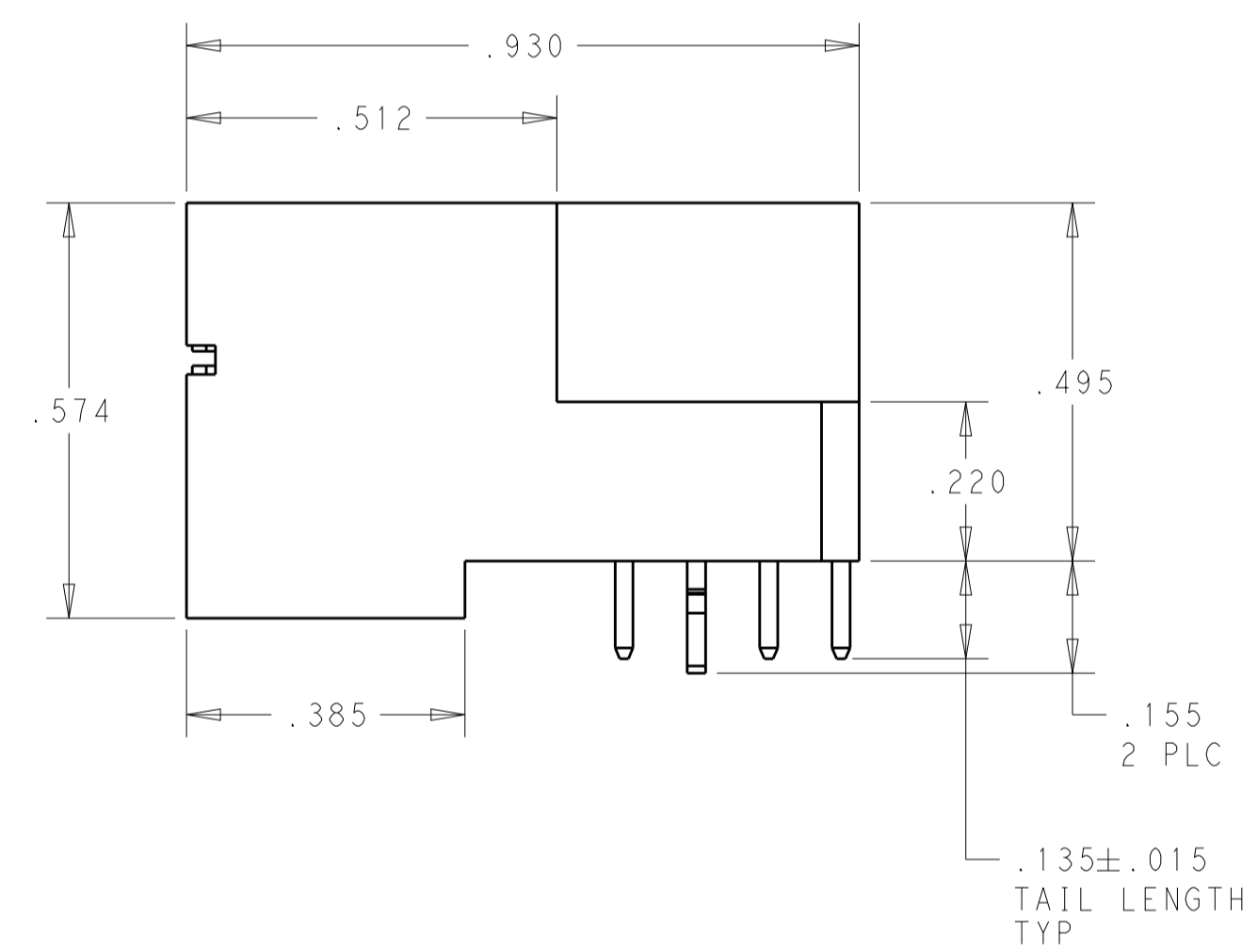
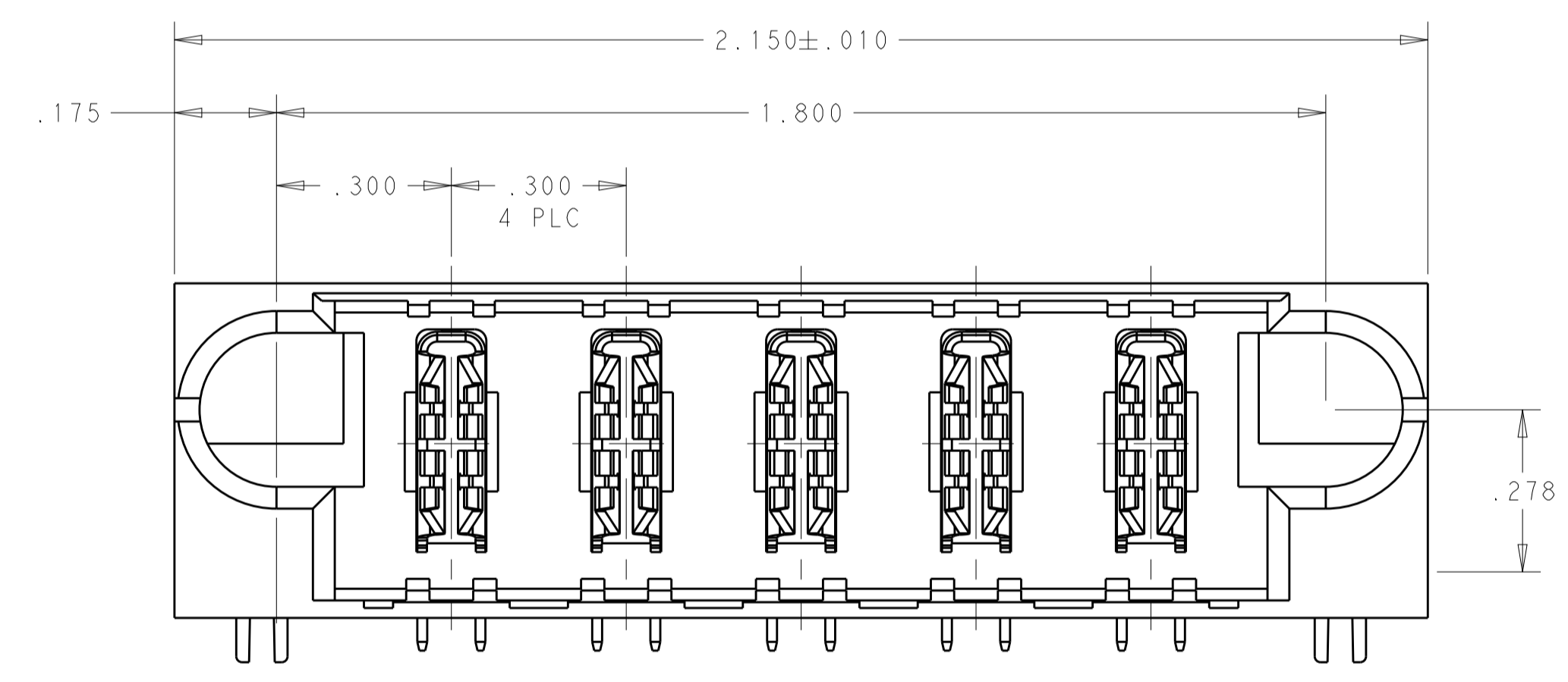

PROPOSAL ONLY

THIS DRAWING IS A CONTROLLED DOCUMENT.		DMN C. ZHOU 19OCT2016	5ACP	2-6450123-0
DIMENSIONS: INCHES		CHK C. ZHOU 19OCT2016	DESCRIPTION	PART NUMBER
TOLERANCES UNLESS OTHERWISE SPECIFIED: 0 PLC ±. 2 PLC ±. 3 PLC ±.005 4 PLC ±.0020 ANGLES ±.7°		APVD S. ZHAO 19OCT2016	TE Connectivity NAME RIGHT ANGLE HEADER, SOLDER MULTI-BEAM XL	
FINISH		PRODUCT SPEC 108-1973		
MATERIAL		APPLICATION SPEC 114-13038	SIZE	CAGE CODE
CUSTOMER DRAWING		WEIGHT	A100779	2-6450123-0
SCALE		4:1	SHEET	1 OF 2
REV		1		

REVISIONS				
P.	LTN.	DESCRIPTION	DATE	APVD.
-	-	SEE SHEET 1	-	-

PART NUMBER	ROWS	POWER				
		P1	P2	P3	P4	P5
2-6450123-0	D	PM	PM	PM	PM	PM
	C					
	B					
	A					
5ACP	HD	HD	HD	HD	HD	

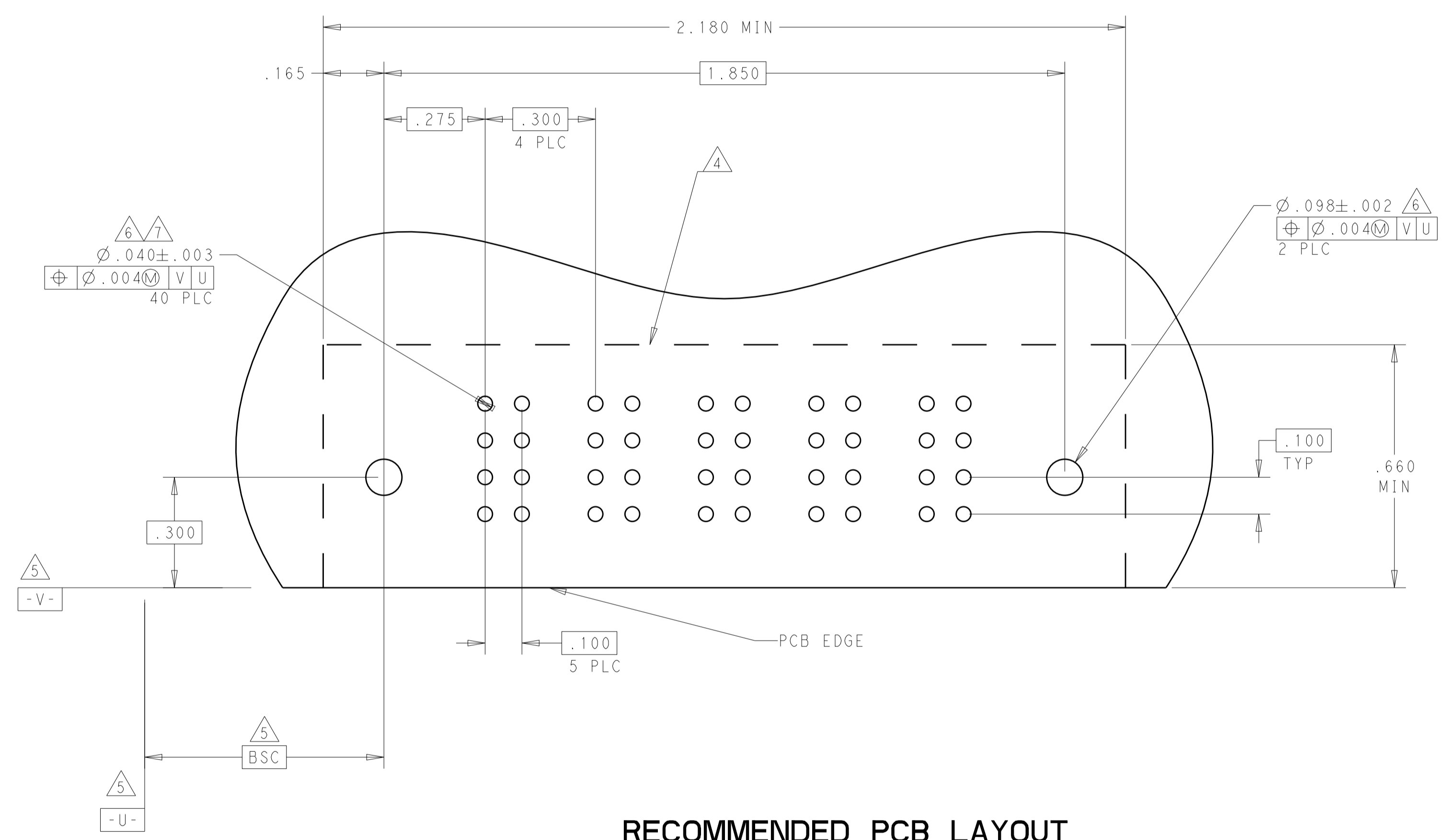

RECOMMENDED PCB LAYOUT

STD SOLDER TYPE POWER CONTACT, .135 TAIL LENGTH, 4-BEAM		PM
HOLD DOWN, MULTI-BEAM		HD
DESCRIPTION		IDENTIFIER
THIS DRAWING IS A CONTROLLED DOCUMENT. DWG: C.ZHOU 19OCT2016 CHK: C.ZHOU 19OCT2016 APVD: S.ZHAO 19OCT2016		
DIMENSIONS: INCHES TOLERANCES UNLESS OTHERWISE SPECIFIED: 0 PLC ± 1 PLC ± 2 PLC ± 3 PLC ±.005 4 PLC ±.0020 ANGLES ±.2°		NAME: RIGHT ANGLE HEADER, SOLDER MULTI-BEAM XL PRODUCT SPEC: 108-1973 APPLICATION SPEC: 114-13038 WEIGHT: - FINISH: 3
MATERIAL: 2		SIZE: A1 CAGE CODE: 00779 DRAWING NO: C=2-6450123-0 RESTRICTED TO: - CUSTOMER DRAWING
SCALE: 4:1		SHEET 2 OF 2 REV 1