

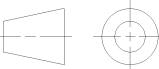

DWG NO
C-2-528041-4

CRIMP DATA (TE TERMINAL)

TERMINAL NAME		SHIELD CRIMP HVA280-3pxm					
CRIMP	SIZE	TYPE	RANGE				
WIRE	(X)	(X)	(X)				
INSULATION	(X)	HEX	(X)				
WIRE STRIP LENGTH	31 ±1	APPLICATOR INSTRUCTION					
TERMINAL APPLICATION SPEC 114-13253		PRODUCT SPECIFICATION			FEED		
TERMINALS APPLIED		CABLE			SEALS		
1587718-1		HITACHI (3x2,5 mm ²) ECS-038					
1587723-1		HUBER+SUHNER (3x2,5 mm ²) 12 585 215 B					
1587724-1		HUBER+SUHNER (2x2,5 mm ²) 12 582 307 B					
WIRE SIZE		CRIMP HEIGHT		REF SETTINGS			
2,5mm ²		9,8					
REMARK:							
DIE-SET used to apply HVA280-3pm Plug Connector (see 114-13253)							
TYPE: DIE-SET WITH LOCATOR FOR SHIELD CRIMP							
TERMINATOR:							
EMEA: HV CRIMPING MACHINE 528008-4							
USA: HV CRIMPING MACHINE 1-528008-4							
P	LTR	REVISION RECORD	DATE	DWN	APVD		
A		INITIAL RELEASE	10APR13	WI	GS		
B		ECR-14-013923	30SEP14	WI	GS		
C		ECR-17-012558	28FEB18	MG	GS		
D		ECR-19-013795	12SEP19	MG	GS		
				DWN	10APR2013	CHK	
				C.Witt		C.Witt	
				APVD	10APR2013	APVD	
				G.Stegmayer		G.Stegmayer	
				WEIGHT, kg	DIMENSION	MATERIAL	
				-	mm	-	
				HT TR			
				-			
				 TE Connectivity			
				<small>TOLERANCES UNLESS OTHERWISE SPECIFIED</small>			
							
				NAME DIE SET, INCL. LOCATOR HVA280			
				RESTRICTED TO -			
				SCALE -		SIZE A4	
				DRAWING NO C-2-528041-4		SHEET 1 of 3	
				REV D			
<small>THIS INFORMATION IS CONFIDENTIAL AND PROPRIETARY TO TYCO ELECTRONICS CORPORATION AND ITS WORLD-WIDE SUBSIDIARIES AND AFFILIATES (TE). IT MAY NOT BE DISCLOSED TO ANYONE, OTHER THAN TE PERSONNEL, WITHOUT AUTHORIZATION FROM TE (www.TE.com).</small>							
<small>THIS DRAWING IS A CONTROLLED DOCUMENT</small>							

POS	QTY	TE P/N	REV	DESCRIPTION	S=Spare Parts W=Wear Parts	S	W
1	1	9-1579019-2	B	DIE SET HVA280	<input checked="" type="checkbox"/>	<input type="checkbox"/>	<input type="checkbox"/>
2	1	563080-4	D	TOOLING ASSEMBLY HVA280-3PM PLUG	<input checked="" type="checkbox"/>	<input type="checkbox"/>	<input type="checkbox"/>
3	1	9-519714-2	A	STOP PLATE	<input checked="" type="checkbox"/>	<input type="checkbox"/>	<input type="checkbox"/>
4	1	8-519699-0	A	SHEET METAL STOP	<input checked="" type="checkbox"/>	<input type="checkbox"/>	<input type="checkbox"/>
5	2	519000-7	A	SCREW, CAP, SOCKET HD, METRIC	<input checked="" type="checkbox"/>	<input type="checkbox"/>	<input type="checkbox"/>
6	1	9-519637-2	A	TYPE PLATE, HV TOOLING	<input checked="" type="checkbox"/>	<input type="checkbox"/>	<input type="checkbox"/>
7	2	2168078-1	A	SCREW,DRIVE,ROUND HD,METALLIC,	<input checked="" type="checkbox"/>	<input type="checkbox"/>	<input type="checkbox"/>

REMARKS:										USED ON		
										-		
P	LTR	REVISION RECORD	DATE	DWN	APVD	PRINTED	DWN	10APR13	CHK	10APR13	APVD	10APR13
-	-	SEE SHEET 1	-	-	-	24SEP19	C.Witt		C.Witt		G.Stegmayer	
-	-	-	-	-	-			CUSTOMER PART LIST		 TE connectivity TE Connectivity		
-	-	-	-	-								
THIS DRAWING IS UNPUBLISHED. RELEASED FROM PUBLICATION -,- ©COPYRIGHT - BY TYCO ELECTRONICS CORPORATION. ALL INTERNATIONAL RIGHT RESERVED.						NAME			RESTRICTED TO			
						DIE SET, HVA 280 - 3PM HEX 9.3			-			
SCALE		SIZE		DRAWING NO		SHEET		REV				
-		A4		C-2-528041-4		2 / 3		D				

THIS DRAWING IS UNPUBLISHED. RELEASED FOR PUBLICATION 20
 © COPYRIGHT 20 BY - ALL RIGHTS RESERVED.

REVISIONS				
P	LTR	DESCRIPTION	DATE	APVD
		SEE SHEET 1		

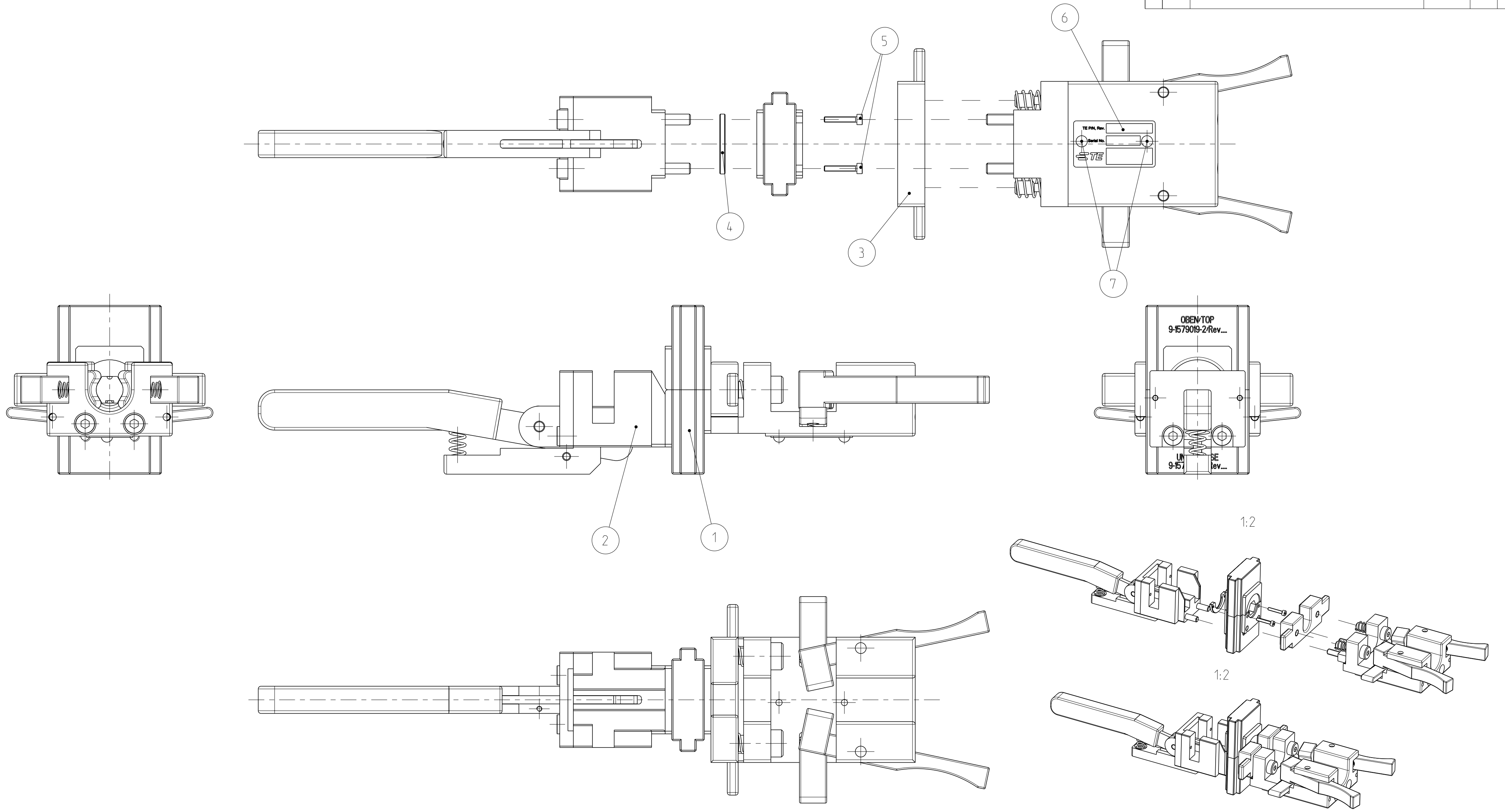

Einheit in Kombination mit hydraulischer Handzange PN 9-1579009-1 oder HV Crimp Maschine PN 528008-4 mit Adapter PN 541868-1 verwendbar
 Unit can be used with hydraulic hand tool PN 9-1579009-1 or HV Crimping machine PN 528008-4 with adapter PN 541868-1

THIS DRAWING IS A CONTROLLED DOCUMENT.		DWN C. Witt	10APR2013	 TE Connectivity	
DIMENSIONS: mm		CHK C. Witt	10APR2013		
TOLERANCES UNLESS OTHERWISE SPECIFIED:		APVD G. Stegmayer	10APR2013	NAME Die set incl. locator HVA280-3pm pl. Matrize inkl. Locator HVA280-3pm pl.	
0 PLC ± 1 PLC ± 2 PLC ± 3 PLC ± 4 PLC ± ANGLES ±° FINISH -		PRODUCT SPEC APPLICATION SPEC		SIZE A2	RESTRICTED TO
MATERIAL		WEIGHT 1.000 kg		CAGE CODE -	DRAWING NO. G-2-528041-4
		CUSTOMER DRAWING		SCALE 1:1	SHEET 3 OF 3 REV D