

REVISION					
ZONE	LTR	ECN	DESCRIPTION	DATE	APPROVED
	C	40702	UPDATE NOTES 1 & 2, BALLOON CALLOUTS	11/15/00	[Signature]
	D		UPDATE PER ECO-10-017486	8/25/10	PJS

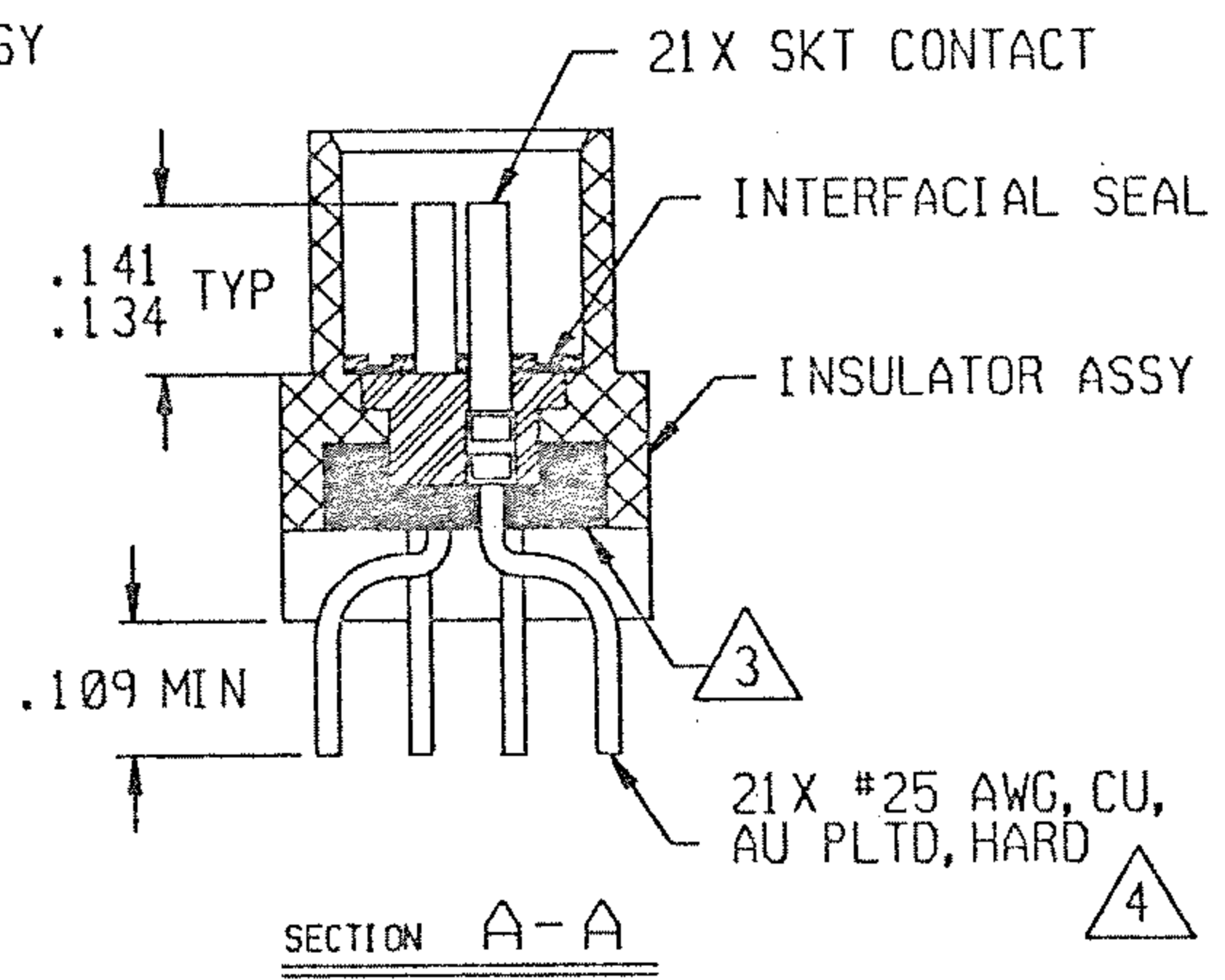

NOTES: UNLESS OTHERWISE SPECIFIED

- 1. MARK PER TPD.
- 2. JACKNUT ASSEMBLIES AS SHOWN ARE ASSEMBLED ON FLANGE.
- 3. EPOXY AS SHOWN. WICKING PERMITTED BEYOND POTTING WELL.
- 4. TERMINAL WIRES ARE TO BE SOLDER DIPPED UP TO MOUNTING SURFACE (MINIMUM).
- 5. LEAD IDENTIFICATION AS SHOWN ARE REFERENCE ONLY. DO NOT APPEAR ON THE PART.
- 6. CRIMP LEADS INTO CONTACTS PER MEP302-05.

UNLESS OTHERWISE SPECIFIED DIMENSIONS ARE IN INCHES. TOLERANCE ARE: FRACTIONS ± 1/8 DECIMALS .XX ± .01 .XXX ± .005 ANGLES ± 2°	APPROVALS		MALCO A MICRODOT COMPANY, INC. 306 PASADENA AVE., SO. PASADENA, CA 91030	METAL SHELL 'D' CONNECTOR, PLUG MCK-**-P-21SST2 094-5306-7003	PROD CODE 845 CASE M
	SIGNATURE	DATE			
	DESIGN				
	CHECKED				
MATERIAL:					
FINISH:	THIS DOCUMENT IS THE PROPERTY OF MALCO, A MICRODOT CO. USE OF THIS DOCUMENT OR ANY PART OF THEREOF IS STRICTLY FORBIDDEN WITHOUT THE EXPRESS WRITTEN PERMISSION OF MALCO, A MICRODOT COMPANY.		SIZE A	CODE IDENT NO. 98278	DRAWING NO. 2-1532012-6
	SCALE: NONE				SHEET 1 OF 1