

THIS DRAWING IS UNPUBLISHED. RELEASED FOR PUBLICATION 20
 © COPYRIGHT 20 BY - ALL RIGHTS RESERVED.

REVISIONS				
P	LTR	DESCRIPTION	DATE	APVD
1		NEW DRAWING	22DEC2014	NK JR

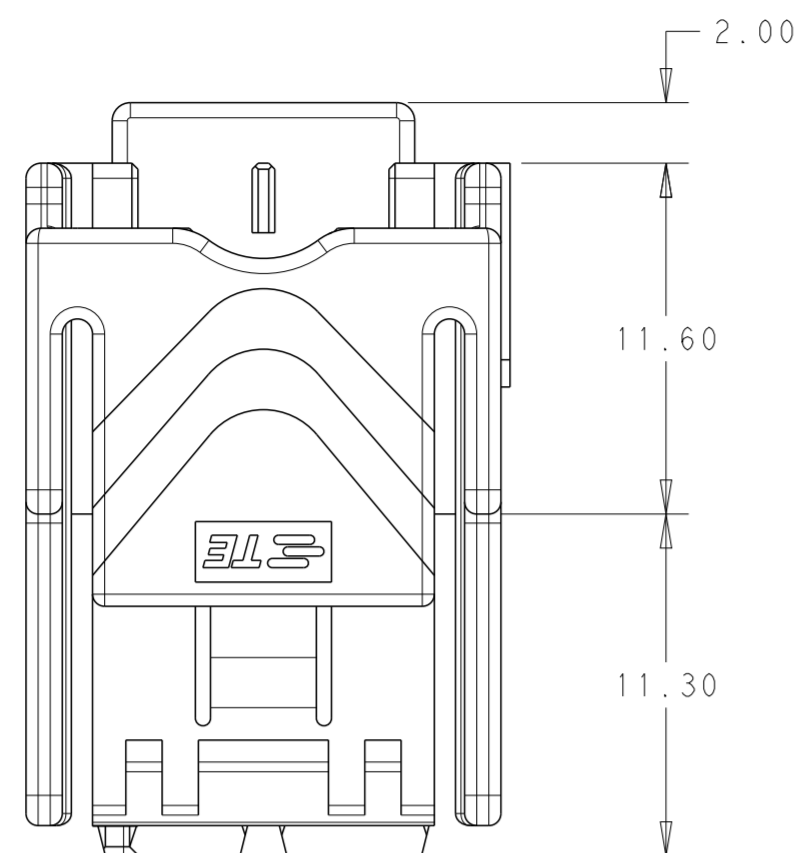

- 1 MATERIAL: NYLON, HIGH TEMPERATURE 150°C KEY A, RED
- 2 MATERIAL MARK: HDT
- 3 FLAMMABILITY RATED PER UL 94V-0
- 4 APPLICABLE CONTACT P/N REC CONTACT: 1971237/1971779/81/83/85/87-*
- 5 MATING CONN, P/N HEADER ASSEMBLY #1969713-2 TPA: 1971777-2

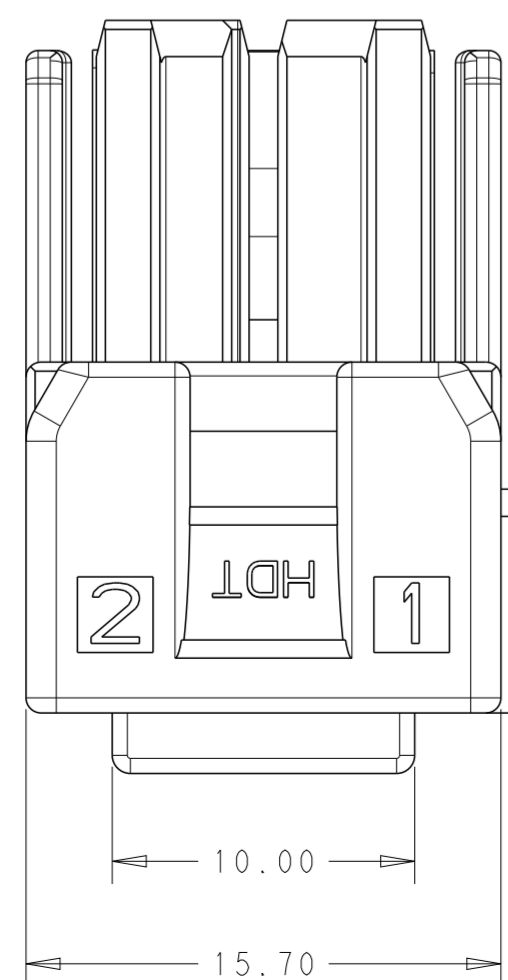
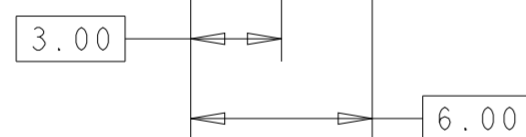
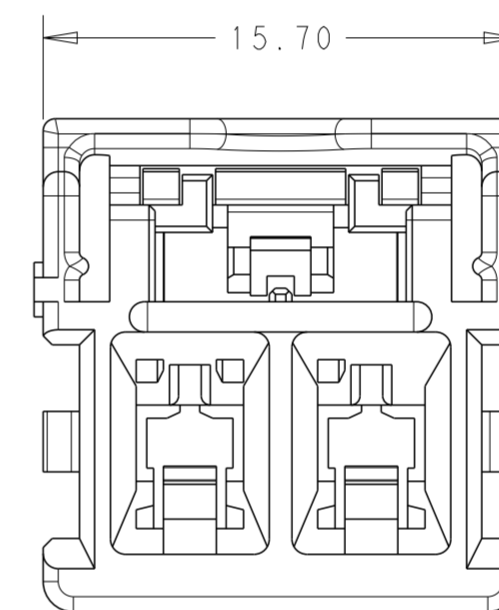
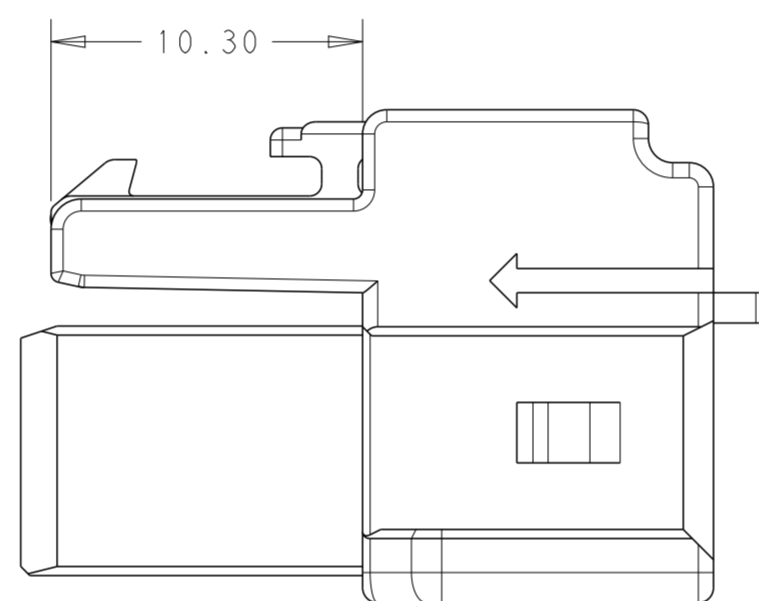
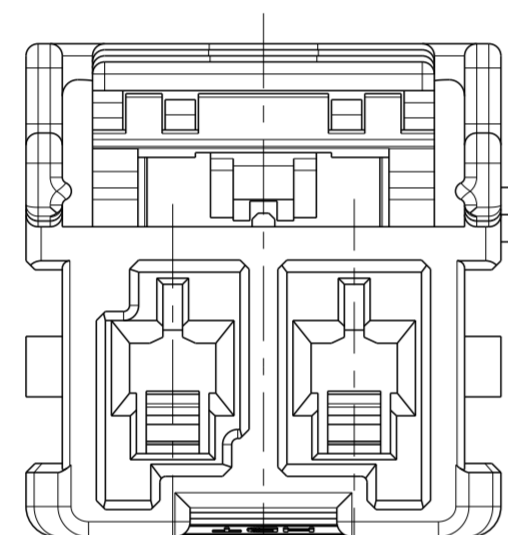

PRELIMINARY - NOT RELEASED FOR PRODUCTION

1969712-2
PART NO

THIS DRAWING IS A CONTROLLED DOCUMENT.		DWN 22DEC2014 NAGALAKSHMI K	STE TE Connectivity	
DIMENSIONS: mm		CHK 22DEC2014 RUTH JEFFREY		
TOLERANCES UNLESS OTHERWISE SPECIFIED:		APVD 22DEC2014 RUTH JEFFREY	NAME PLUG HOUSING, SINGLE ROW POWER TRIPLE LOCK	
0 PLC ±-		PRODUCT SPEC 108-106118	SIZE	RESTRICTED TO
1 PLC ±0.35		APPLICATION SPEC 114-106118	CAGE CODE	
2 PLC ±0.25		WEIGHT	DRAWING NO	
3 PLC ±-		Customer Drawing	A200779	
4 PLC ±-		SCALE	C-1969712	
ANGLES ±-		SHEET	1	OF
FINISH		REV	2	1

THIS DRAWING IS UNPUBLISHED. RELEASED FOR PUBLICATION 20
 © COPYRIGHT 20 BY - ALL RIGHTS RESERVED.

REVISIONS				
P	LTR	DESCRIPTION	DATE	APVD
-		SEE SHEET 1	-	-

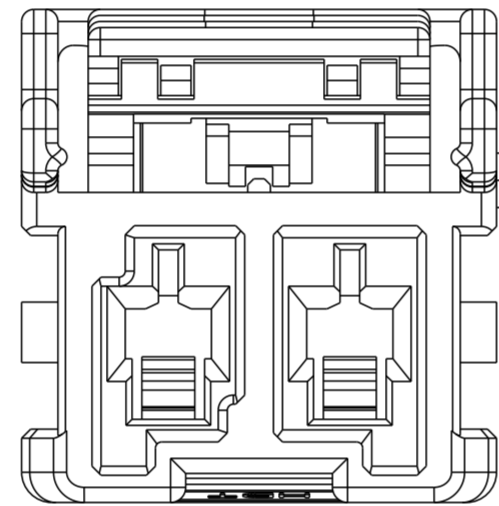
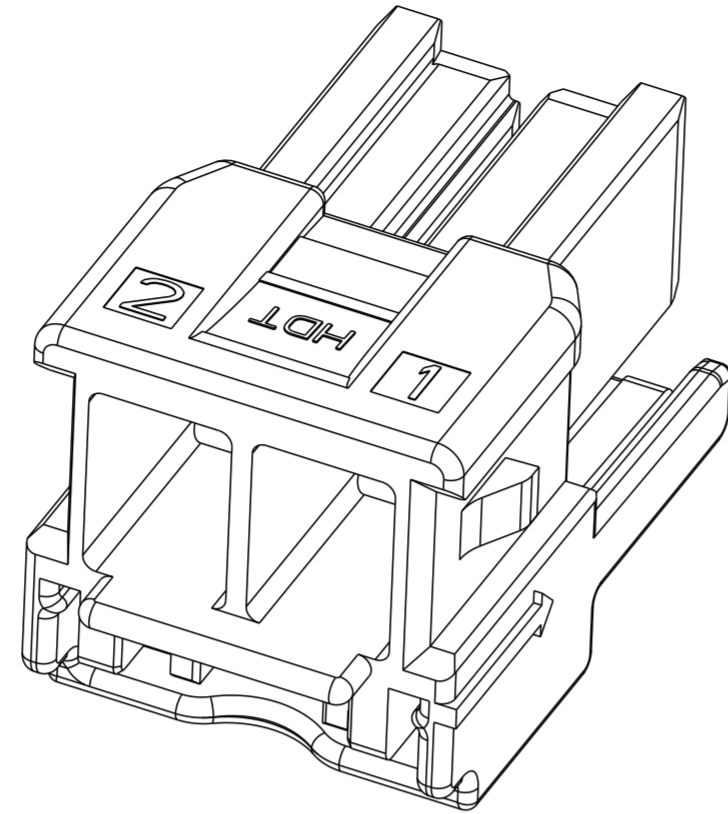

1*2 POSITIONS

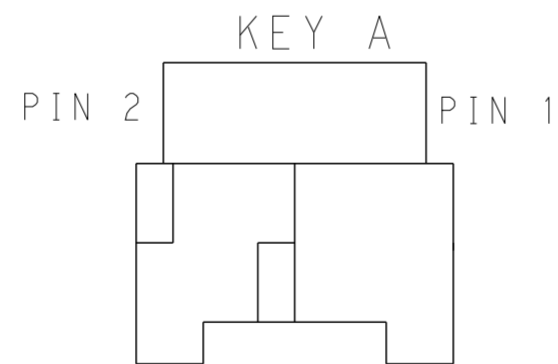

KEYING FOR 1*2 POS.

THIS DRAWING IS A CONTROLLED DOCUMENT.		DWN 22DEC2014 NAGALAKSHMI K	TE Connectivity	
DIMENSIONS: mm		CHK 22DEC2014 RUTH JEFFREY		
TOLERANCES UNLESS OTHERWISE SPECIFIED:		APVD 22DEC2014 RUTH JEFFREY	NAME PLUG HOUSING, SINGLE ROW POWER TRIPLE LOCK	
0 PLC ±		PRODUCT SPEC 108-106118	RESTRICTED TO	
1 PLC ±0.35		APPLICATION SPEC 114-106118	SIZE A200779	CAGE CODE C-1969712
2 PLC ±0.25		WEIGHT -	SCALE -	SHEET 2 OF 2
3 PLC ±		Customer Drawing	REV 1	
4 PLC ±				
ANGLES ±				
FINISH -				
-				