

THIS DRAWING IS UNPUBLISHED. RELEASED FOR PUBLICATION
 © COPYRIGHT BY TYCO ELECTRONICS CORPORATION. ALL INTERNATIONAL RIGHTS RESERVED.

LOC	DIST	REVISIONS					
		P	LTR	DESCRIPTION	DATE	DWN	APVD
G	14		1	PROPOSED	-	-	-

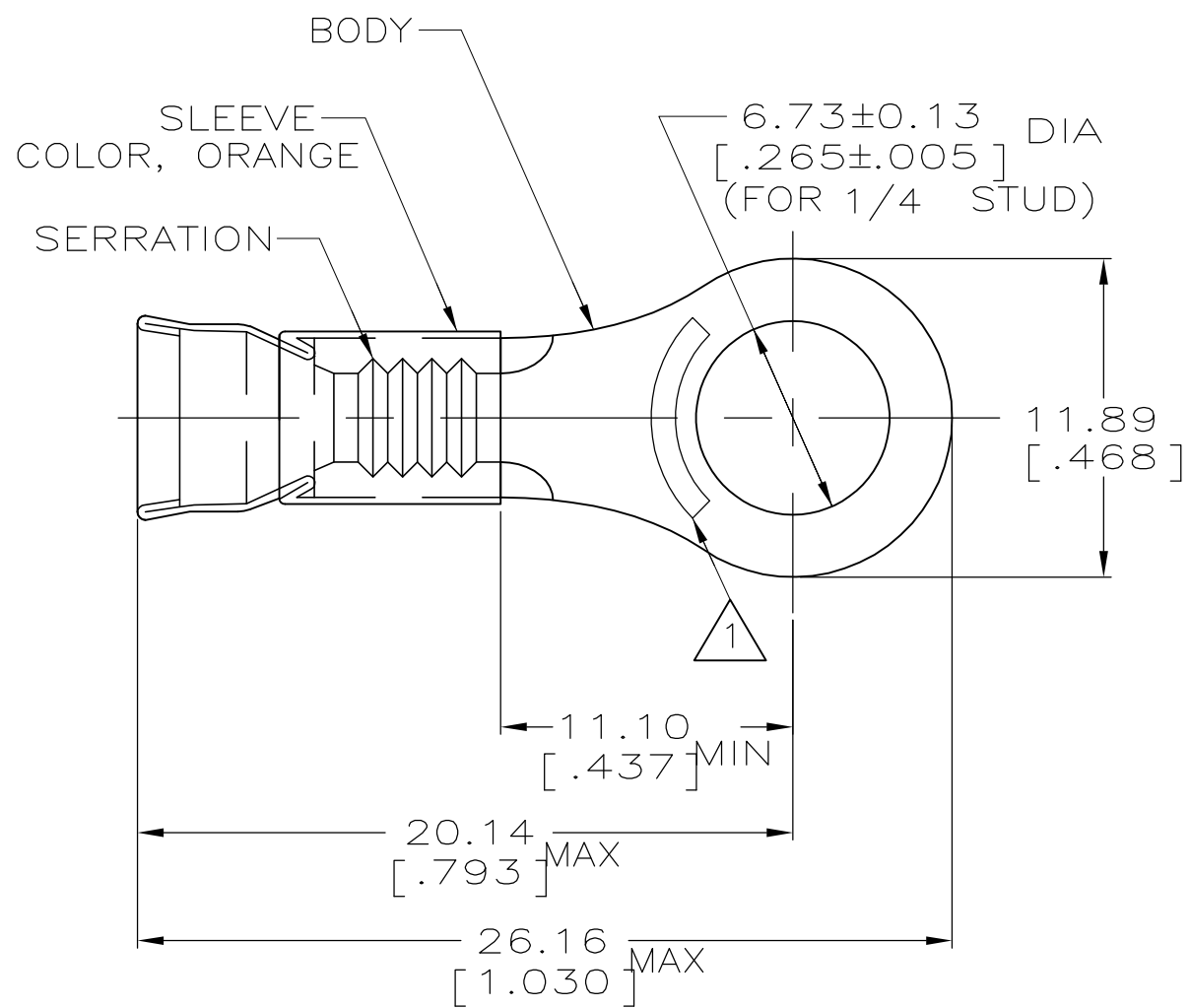

- ① STAMP AMP 16-14 APPROX AS SHOWN
- 2 WIRE INSUL DIA, 3.05-4.32 [.120-.170]
- 3 TONGUE MATL THK, 0.79±0.05 [.031±.002]
- ④ BODY - NICKEL PER ASTM B162
SLEEVE - NICKEL SILVER PER ASTM B122
- 5 RECOMMENDED OPERATING TEMO 649°C MAX
- 6 CIRCULAR MIL AREA
1.04-2.62mm² [2,050-5,180]
STRANDED WIRE
- ⑦ PRELIMINARY - NOT FOR PRODUCTION

QTY	PACKAGE TYPE	PART NO
5000	322341 ON TAPE, REELED	⑦ 1958341-2
2500	322341 ON TAPE, REELED	⑦ 1958341-1

THIS DRAWING IS A CONTROLLED DOCUMENT.		DWN JR RUTH 23MAR10	Tyco Electronics Corporation Harrisburg, PA 17105-3608	
DIMENSIONS: mm [INCHES]		CHK RAY LONDON 23MAR10		
TOLERANCES UNLESS OTHERWISE SPECIFIED:		APVD RAY LONDON 23MAR10	NAME TERMINAL, RING TONGUE, STRATOTHERM, DIAMOND GRIP, WIRE SIZE: 16-14	
0 PLC ± - 1 PLC ± - 2 PLC ± 0.20 [.008] 3 PLC ± - 4 PLC ± - ANGLES ± -		PRODUCT SPEC -	SIZE A3	
MATERIAL ④		FINISH -	CAGE CODE 00779	DRAWING NO C-1958341
		WEIGHT -	RESTRICTED TO -	
CUSTOMER DRAWING			SCALE 4:1	SHEET 1 OF 1
			REV 1	