

THIS DRAWING IS UNPUBLISHED. RELEASED FOR PUBLICATION
 © COPYRIGHT BY TYCO ELECTRONICS CORPORATION. ALL RIGHTS RESERVED.

LOC	DIST	REVISIONS			
P	LTR	DESCRIPTION	DATE	DWN	APVD
G	14	2	CHANGED PLATING THK	15NOV07	JR MS

AMP WIRE RANGE	Listed FILE E13288	LR7189 Certified
12-10 AWG SOLID OR STRANDED	N/A	N/A

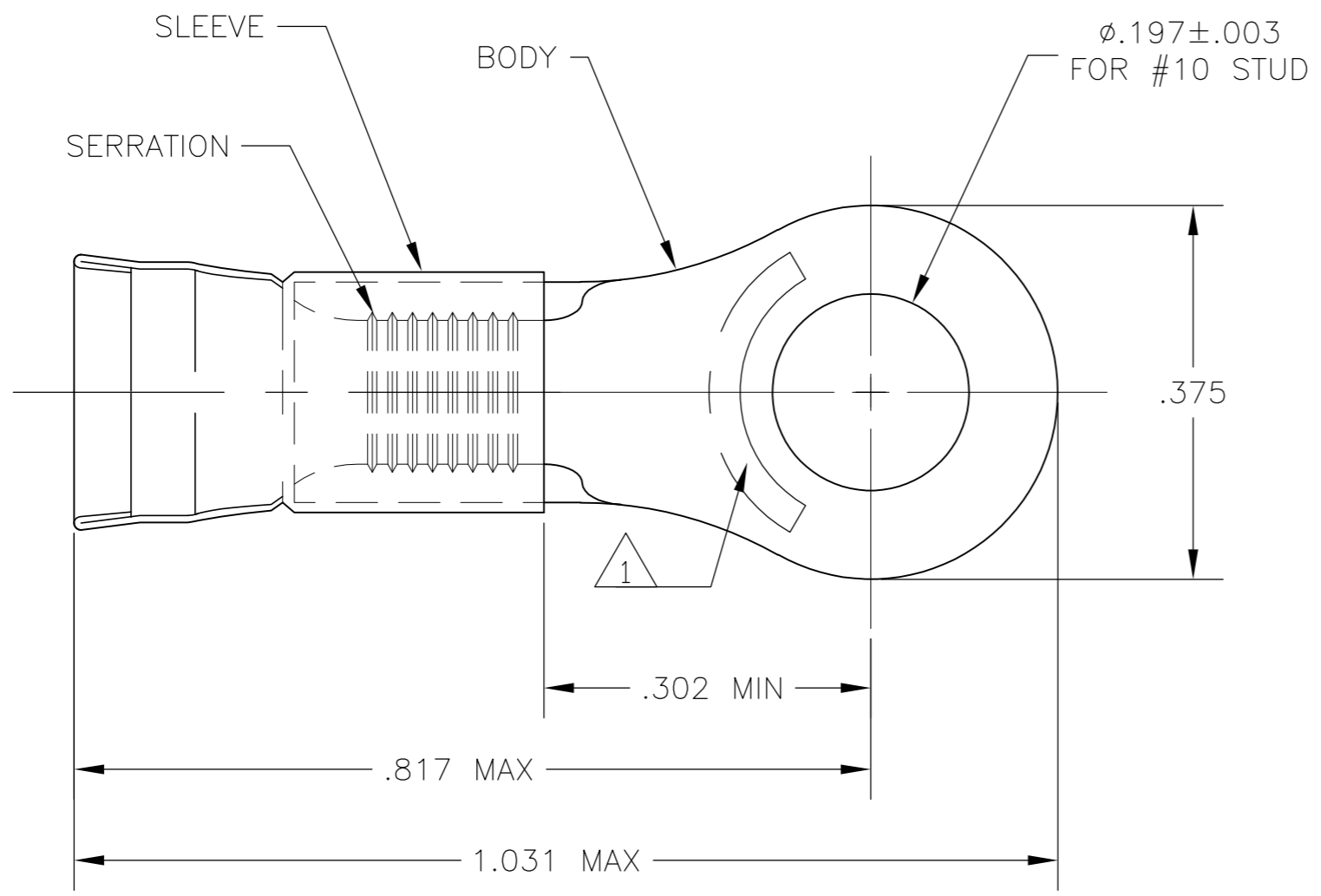

- 1 STAMP AMP 12-10*, APPROX WHERE SHOWN
- 2 WIRE INSULATION DIA IS .150-.230
- 3 TONGUE MATL THK IS .039±.002
- 4 MATERIAL: BODY- COPPER PER ASTM B152
SLEEVE- COPPER PER ASTM B152
- 5 FINISH: BODY & SLEEVE
TIN-LEAD PLATE 60/40, .000300 MIN THK
- 6 PRELIMINARY - NOT FOR PRODUCTION

1000	LOOSE PIECE	△ 1958013-1
QTY	PACKAGE TYPE	PART NO

AMP INCORPORATED CUSTOMER SERVICE SYSTEMS		MAX RECOMMENDED OPERATING TEMPERATURE: 170°C [338°F]	THIS DRAWING IS A CONTROLLED DOCUMENT.		DWN jr_ruth 24AUG06	Tyco Electronics Corporation Harrisburg, PA 17105-3608							
FOR ADDITIONAL PRODUCT INFORMATION OR COPIES OF DRAWINGS AND TECHNICAL DOCUMENTS	PRODUCT INFORMATION CENTER 1-800-522-6752	VOLTAGE RATING: -	DIMENSIONS: INCHES	TOLERANCES UNLESS OTHERWISE SPECIFIED:	CHK MJ SPICER 24AUG06	NAME TERMINAL, RING, DIAMOND GRIP, WIRE SIZE: 12-10AWG							
FOR APPLICATION TOOLING INFORMATION	TOOLING ASSISTANCE CENTER 1-800-722-1111	CIRCULAR MIL AREA: 2.62-6.64mm² [5180-13100] SOLID OR STRANDED		0 PLC ± - 1 PLC ± - 2 PLC ± - 3 PLC ± .008 4 PLC ± - ANGLES ± 5°	APVD MJ SPICER 24AUG06	APPLICATION SPEC		SIZE	CAGE CODE	DRAWING NO	RESTRICTED TO		
FOR ORDER ENTRY	1-800-526-5142	THIS DRAWING IS A CONTROLLED DOCUMENT FOR AMP INCORPORATED. IT IS SUBJECT TO CHANGE AND THE CONTROLLING ENGINEERING ORGANIZATION SHOULD BE CONTACTED FOR THE LATEST REVISION.	MATERIAL - △ 4	FINISH - △ 5	PRODUCT SPEC	WEIGHT		A3	00779	G-1958013	-		
CUSTOMER DRAWING								SCALE	6:1	SHEET	1 OF 1	REV	2