

LOC	DIST	REVISIONS			
P	LTN	DESCRIPTION	DATE	DWN	APVD
B1		REVISED PER ECO-08-022334	09SEP2008	DLD	DLD
B2		REVISED PER ECO-13-006674	23APR2013	DLD	CJS
B3		REVISED PER ECO-17-016061	02NOV2017	JMS	CS

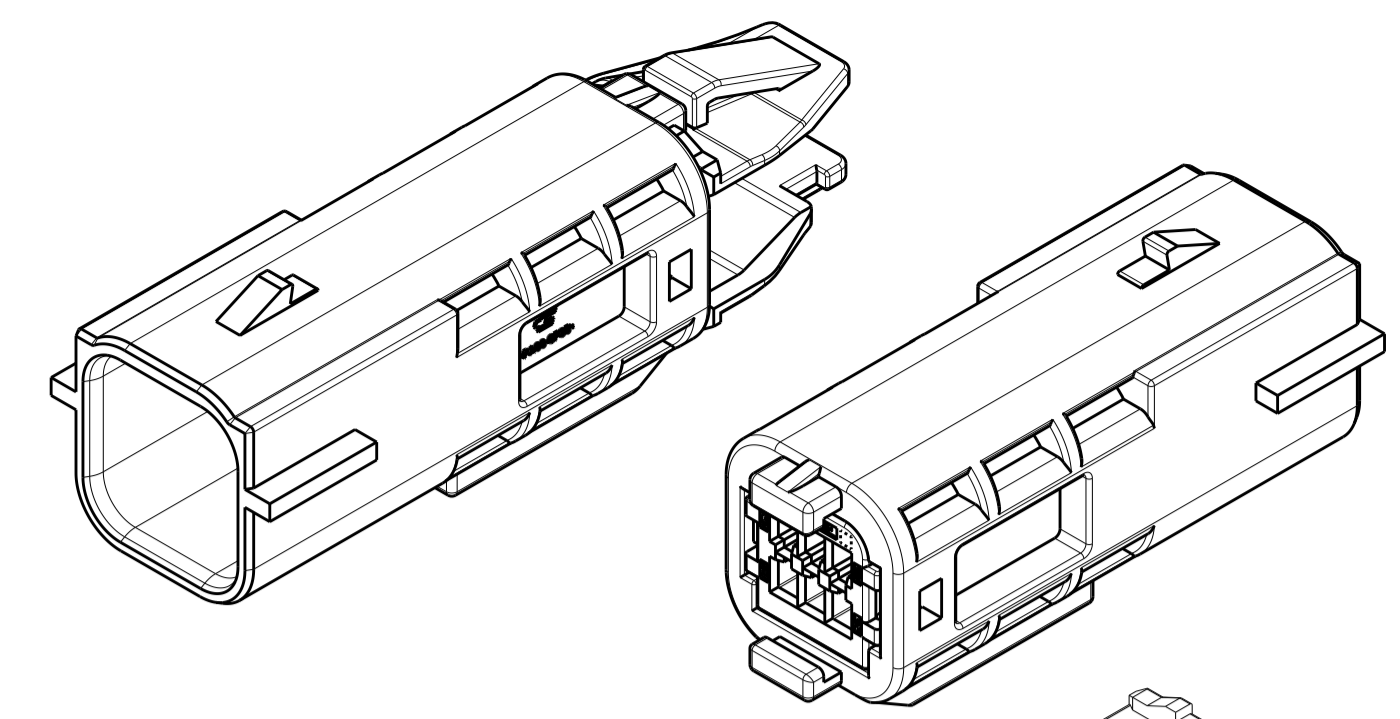

ISOMETRIC VIEWS
SCALE 2:1

- △ CAP HOUSING: NYLON 6/6, GRAY.
- MATTE SEAL: SILICONE, LIGHT BLUE.
- TPA: NYLON 6/6, RED.
- SEAL COVER: NYLON 6/6, BLACK.

- △ TPA SHOWN IN PRE-LATCHED POSITION.
- 3. CAP ASSEMBLY WILL ACCEPT JST TERMINAL PART NUMBER SAITW-A03T-064.
- 4. PARTS HAVE BEEN VALIDATED TO GMW3191, DATED DECEMBER 2007, EXCEPT 4.12.1.5.4: CLOSED TPA LOCKING FORCE TO BE > 15N.
- 5. SEALING CLASS - 3.
- 6. VIBRATION CLASS - 1.
- 7. TEMPERATURE CLASS - 3.
- 8. MATES WITH PART NUMBER 1924211.

WIRE DRESS COVER
1924291-1
MUST BE PURCHASED
SEPARATELY

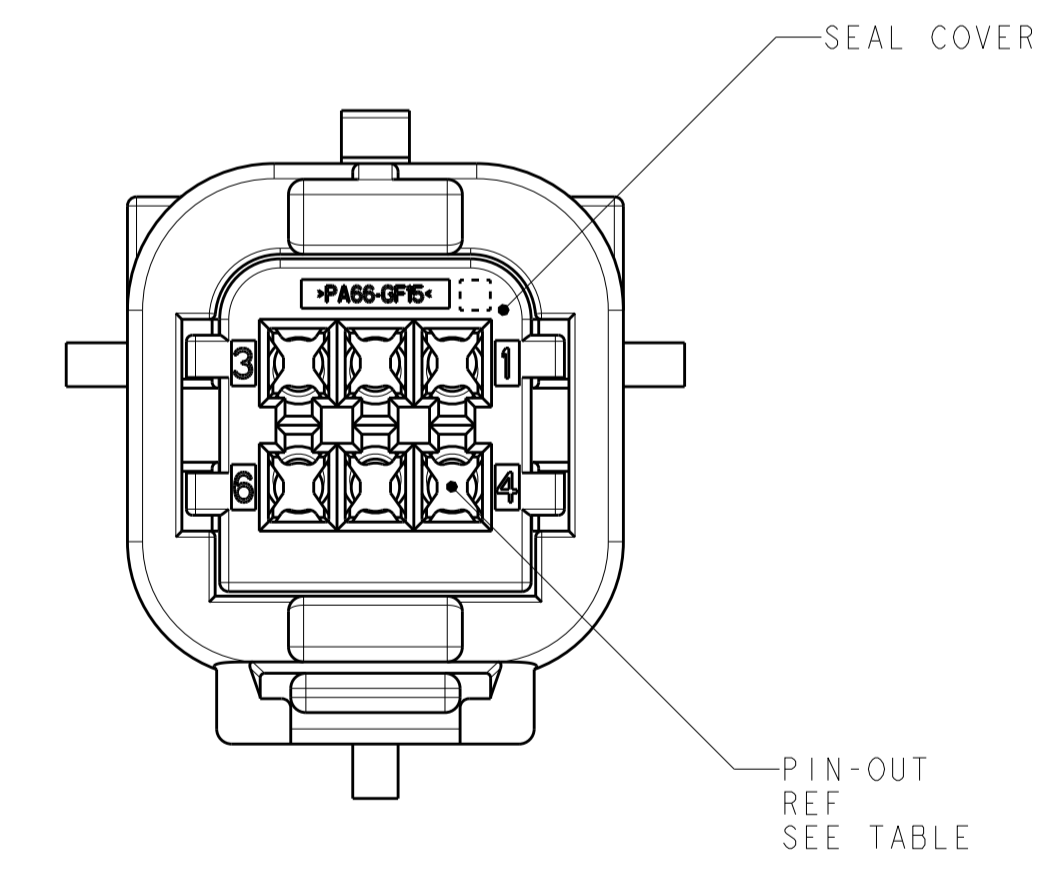
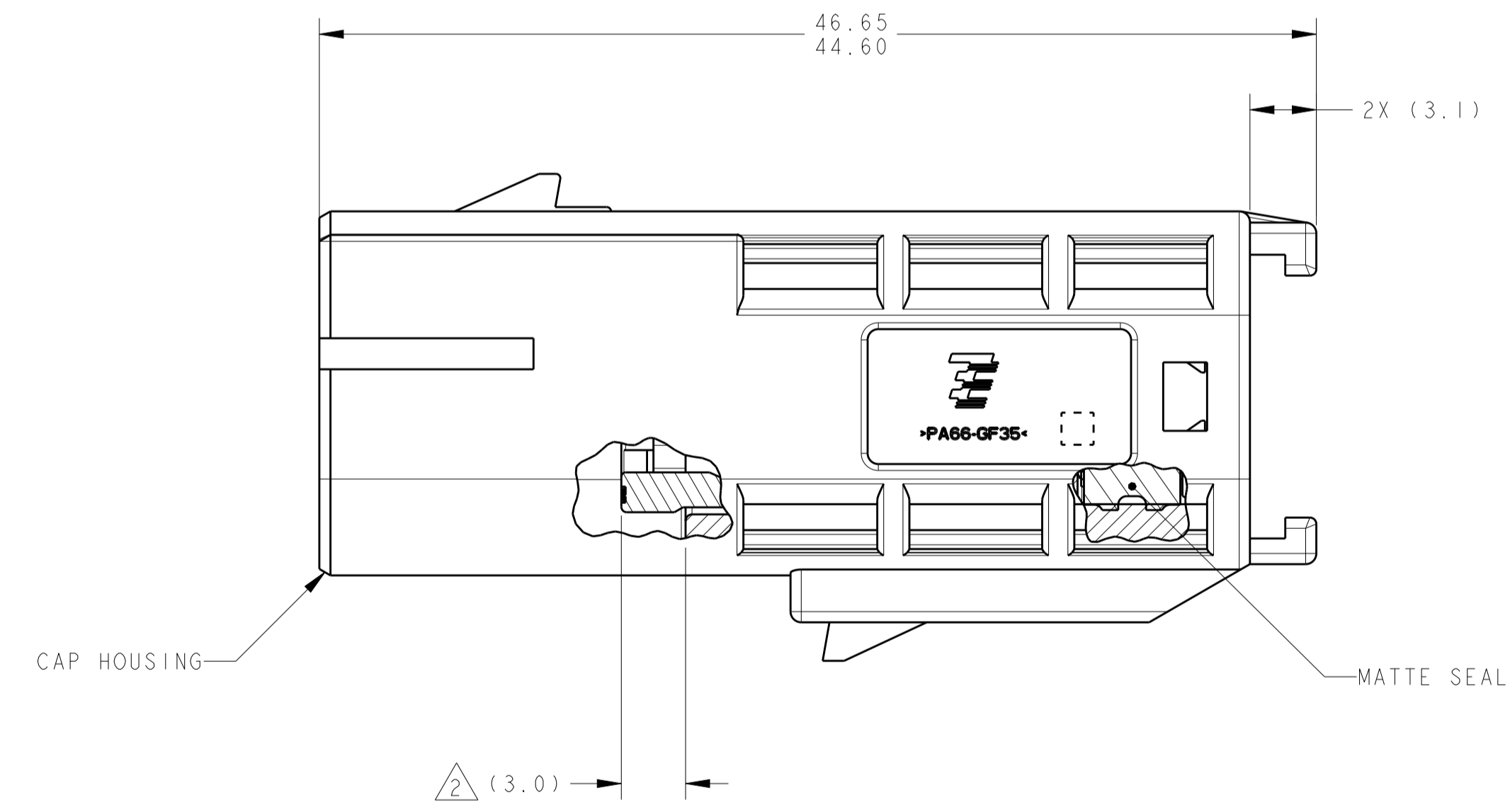
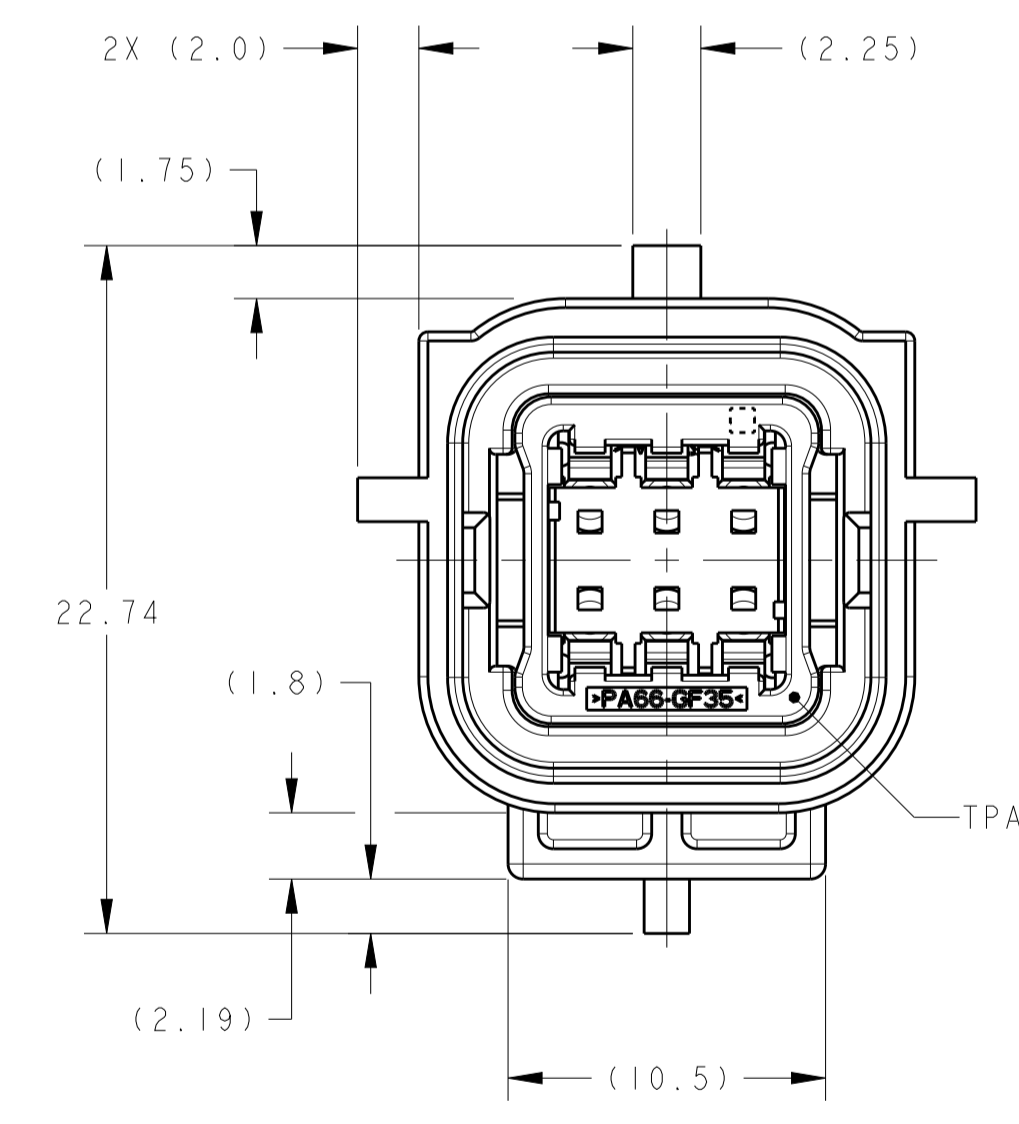
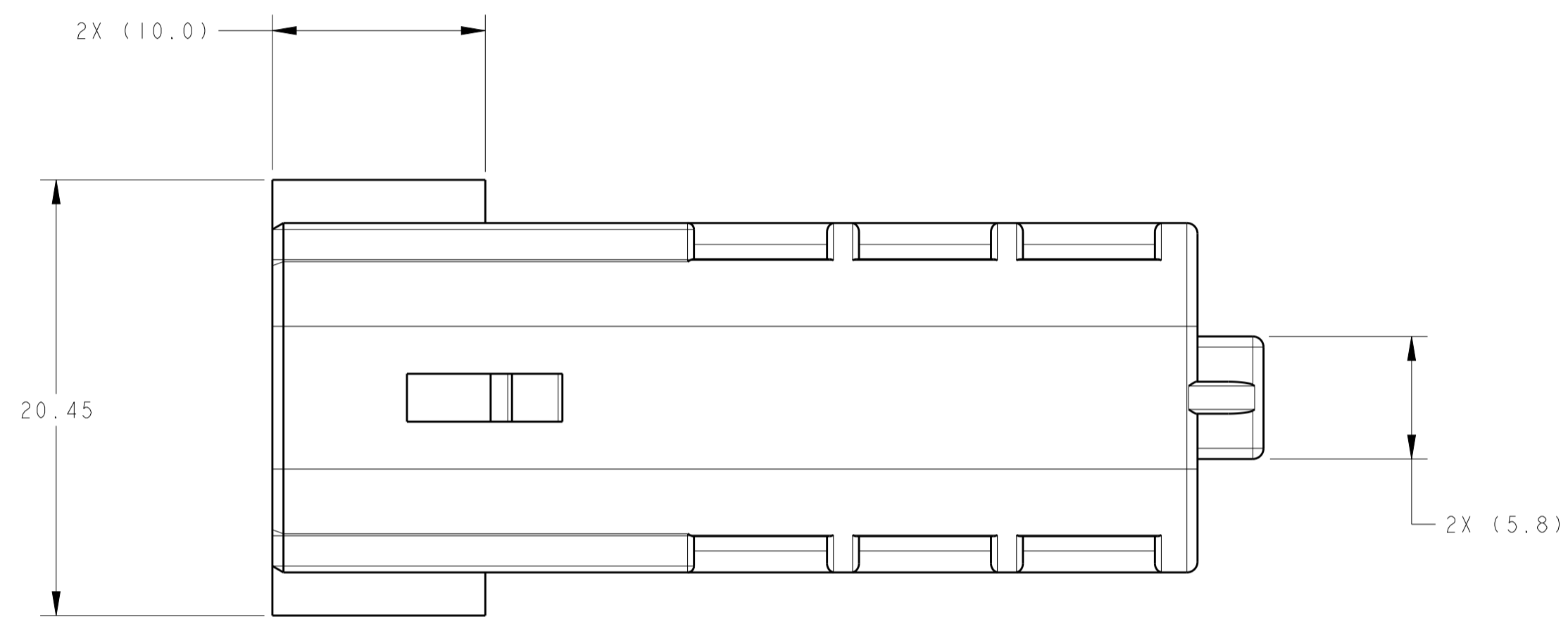

O	O	X	O	O	O	B	1924212-6
X	X	X	X	X	X	B	1924212-2
O	O	O	O	O	O	B	1924212-1
CIR 1	CIR 2	CIR 3	CIR 4	CIR 5	CIR 6	CODING REF	PART NUMBER
PIN-OUT							
O = OPEN CIRCUIT; X = CLOSED CIRCUIT							

THIS DRAWING IS A CONTROLLED DOCUMENT.

DWN: D. J. HARDY 27MAR2007
CHK: E. C. BRANDBERG 25JUN2007
APVD: E. C. BRANDBERG 25JUN2007

TE Connectivity

NAME: CAP ASSEMBLY, 6 POSITION, 2x3, SEALED, 0.64mm

SIZE: A1 CAGE CODE: 100779 DRAWING NO: 1924212

RESTRICTED TO: Customer Drawing

SCALE: 4:1 SHEET: 1 OF 1 REV: B3