

THIS DRAWING IS UNPUBLISHED. RELEASED FOR PUBLICATION 20
 © COPYRIGHT 20 BY - ALL RIGHTS RESERVED.

LOC	DIST	REVISIONS					
		P	LTR	DESCRIPTION	DATE	DWN	APVD
CE	16		2	REVISE ITEMS 1 AND 3	30JAN06	KG	DW
			3	REVISE LOGO	24MAR2011	KG	DW
			4	ECO-20-012155	30AUG2020	LN	DW

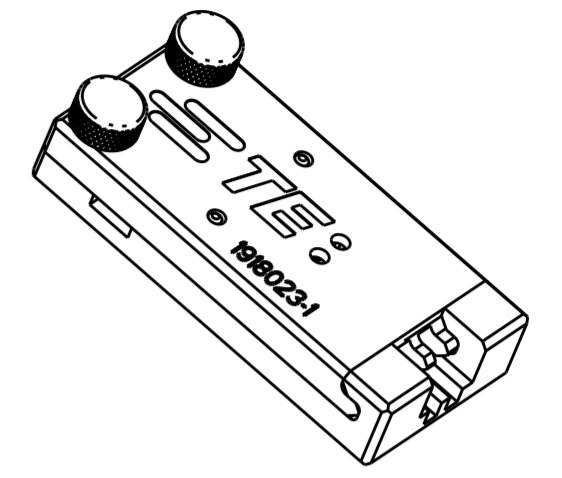

SCALE 1:1

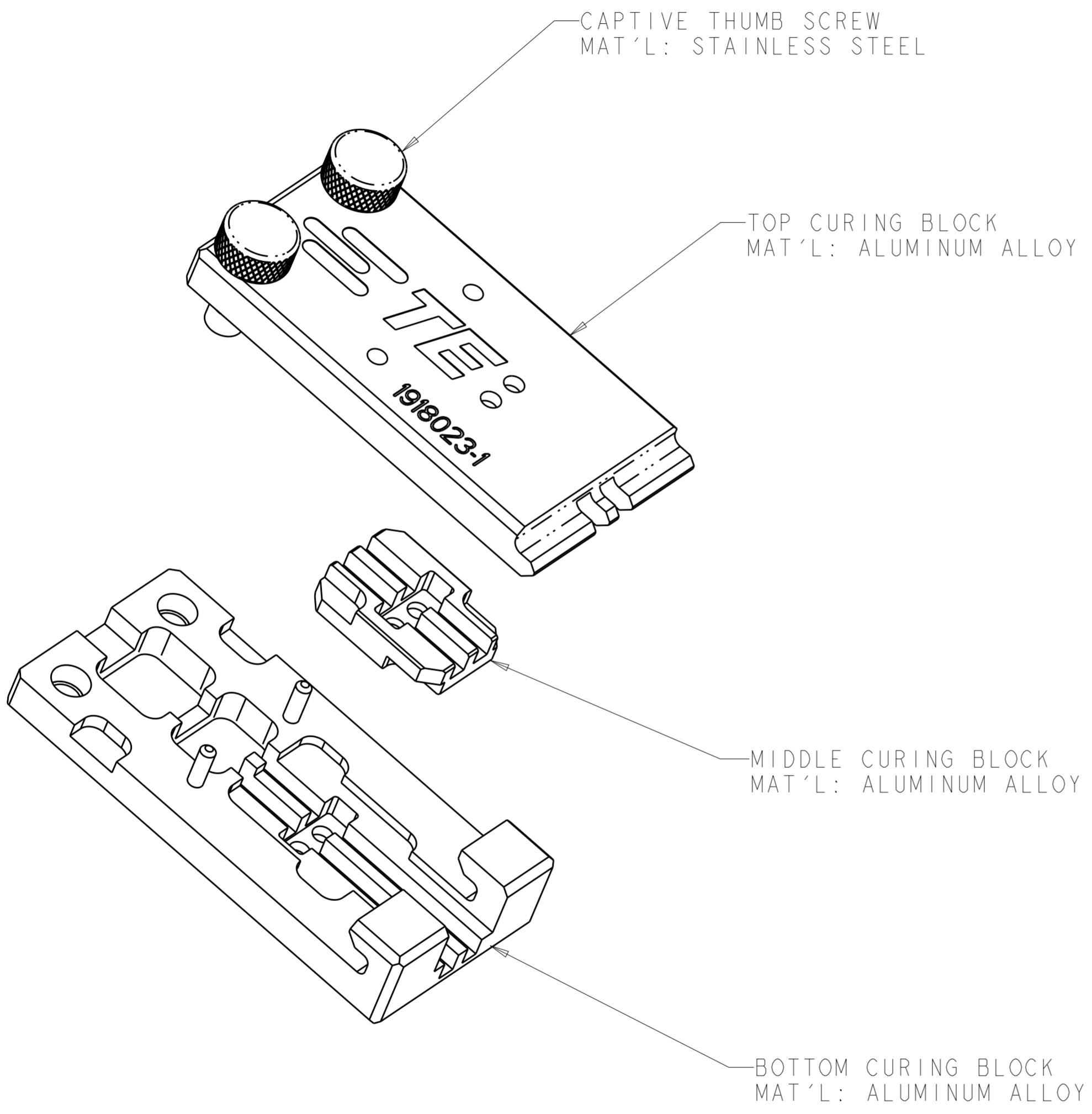
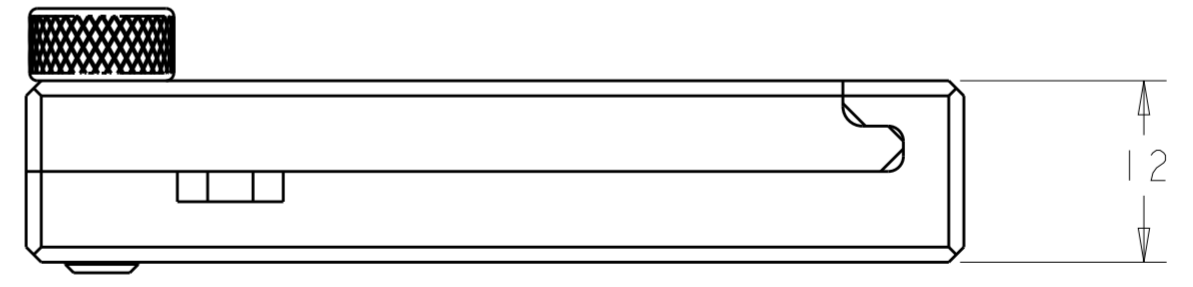
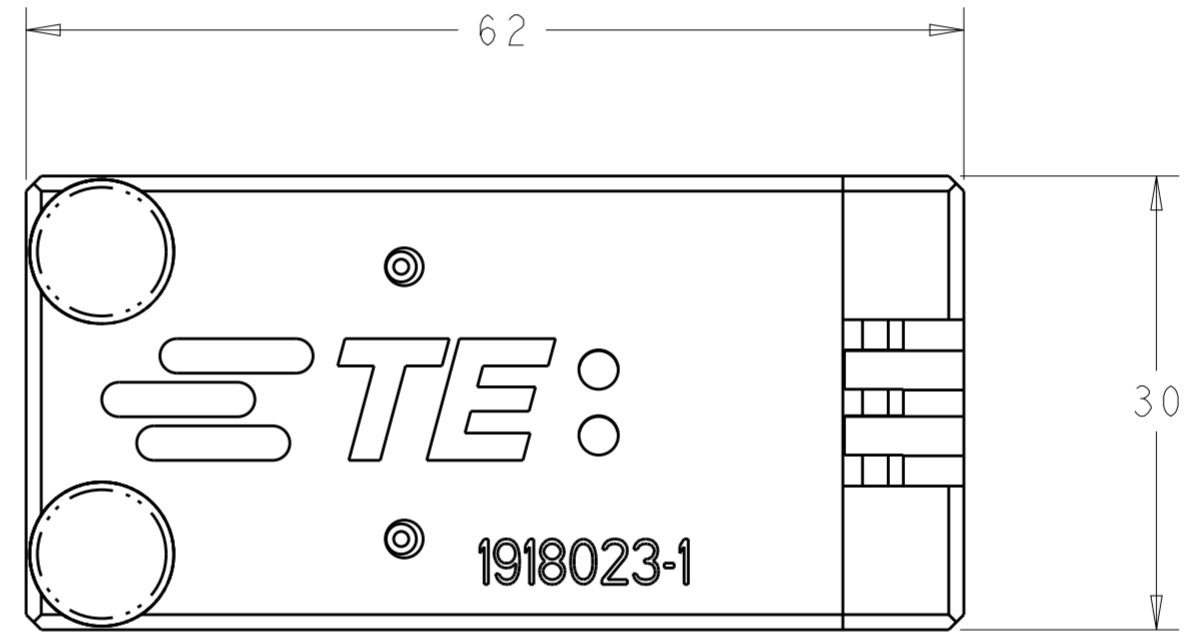

- ALL DIMENSIONS ARE FOR REFERENCE ONLY.
- USE THIS CURING FIXTURE WHEN TERMINATING FERRULES FOR THE FOLLOWING CONNECTOR:
A. PRO BEAM MINI PLUG

DESIGN APPROVED THIS PRINT IS
PRELIMINARY
 TO FIRST PIECE APPROVAL
 CONTACT PRODUCT ENGINEERING
 BEFORE USING THIS PRINT

THIS DRAWING IS A CONTROLLED DOCUMENT.		DWN K. GLATFELTER 01NOV2005	STE TE Connectivity	
DIMENSIONS: mm		CHK D. WERTMAN 07NOV2005		
TOLERANCES UNLESS OTHERWISE SPECIFIED: 0 PLC ± 1 PLC ± 2 PLC ± 3 PLC ± 4 PLC ± ANGLES ±		APVD D. WERTMAN 07NOV2005	NAME CURING FIXTURE, PRO BEAM MINI	
MATERIAL AS LISTED		FINISH HARD ANODIZE (AL ONLY)	PRODUCT SPEC -	APPLICATION SPEC -
WEIGHT -		CUSTOMER DRAWING	SIZE A2	CAGE CODE 00779
SCALE 2:1		DRAWING NO. C-1918023	RESTRICTED TO	
SHEET 1		OF 1		REV 4

1918023-1
PART NUMBER