

LOC	DIST	REVISIONS					
DS	-	P	LTR	DESCRIPTION	DATE	DWN	APVD
			A	RELEASE	07.NOV.'08	GC	JK
			B	REVISED(ECR-09-011753)	03.APR.'09	GC	JK



REFER TO PRODUCT GROUP DRAWINGS  
1897787 FOR LATEST INFORMATIONS  
ABOUT THE PART

20

RELEASED FOR PUBLICATION

THIS DRAWING IS UNPUBLISHED.

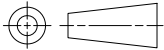
© COPYRIGHT 20 BY TYCO ELECTRONICS CORPORATION. ALL RIGHTS RESERVED.

<p>DIMENSIONS:</p> <p>mm</p> <p>TOLERANCES UNLESS OTHERWISE SPECIFIED:</p> <p>0 PLC ±</p> <p>1 PLC ±0.05</p> <p>2 PLC ±0.13</p> <p>3 PLC ±0.013</p> <p>4 PLC ±0.0001</p> <p>ANGLES ±</p> 	DWN GC KWON	03JUN2009	MATERIAL	-	FINISH	-			
	CHK KT LIM	-			AMP KOREA				
	APVD JK SONG	-			kyungsan, korea				
	PRODUCT SPEC	-	NAME TAB DIELECTRIC FOR RF STRIPLINE						
	APPLICATION SPEC	-	SIZE	CAGE CODE	DRAWING NO	RESTRICTED TO			
WEIGHT	-	A4	00779	C=1897797	-				
CUSTOMER DRAWING				SCALE	2:1	SHEET	1 OF 1	REV	B