

LOC	DIST	REVISIONS			
P	LTR	DESCRIPTION	DATE	DWN	APVD
	A	RELEASED	19.APR'07	IS	JK
	B	REVISED(PCR-08-002250)	18.MAR'08	DG	HG

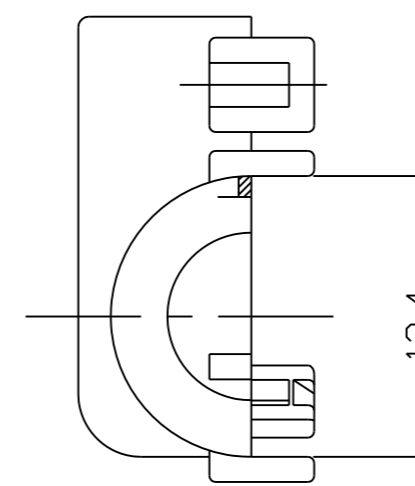

SECTION A-A
SCALE 2:1

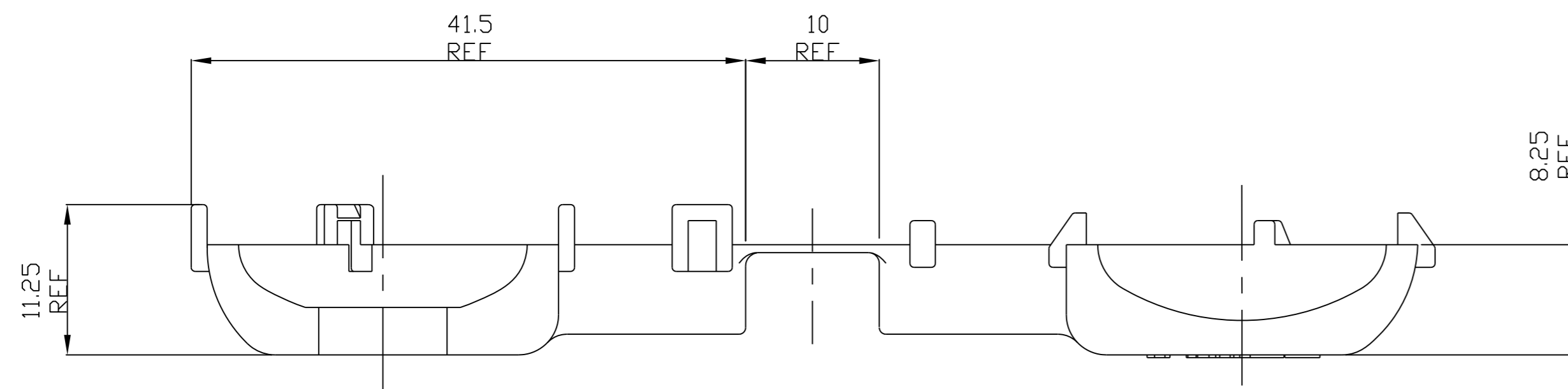
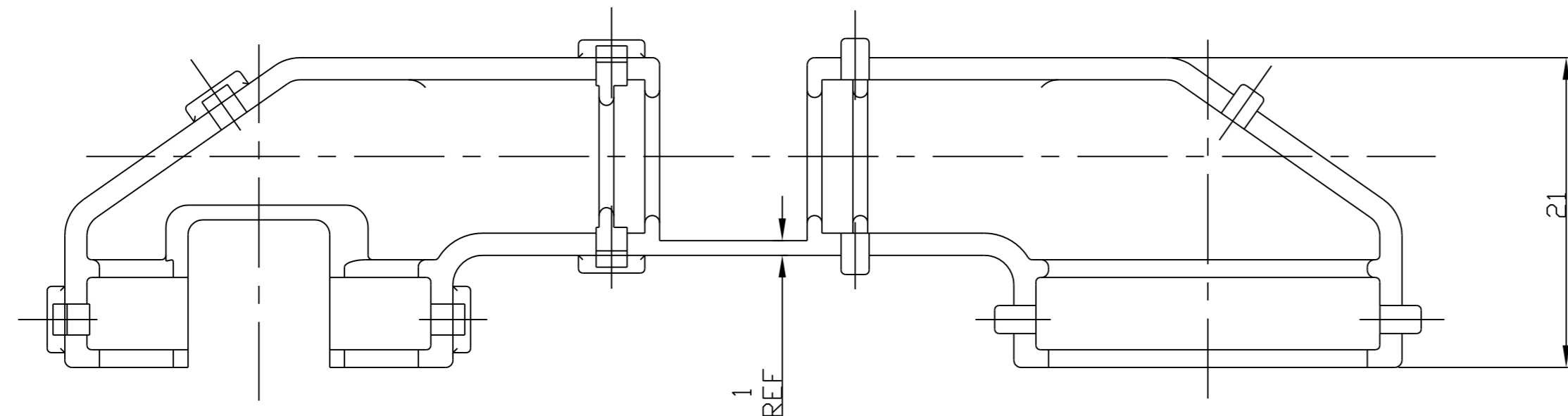
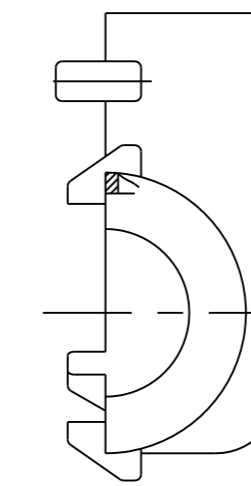

SECTION C-C
SCALE 2:1

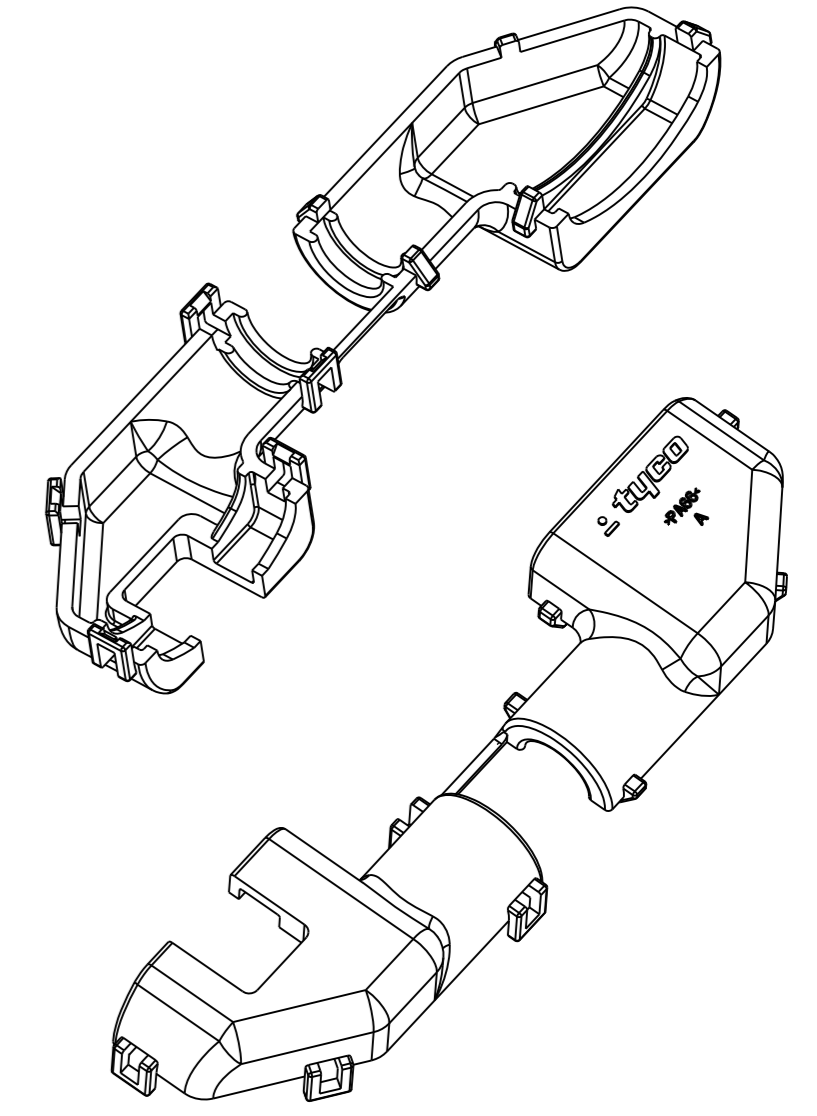

ISOMETRIC VIEW
SCALE 1:1

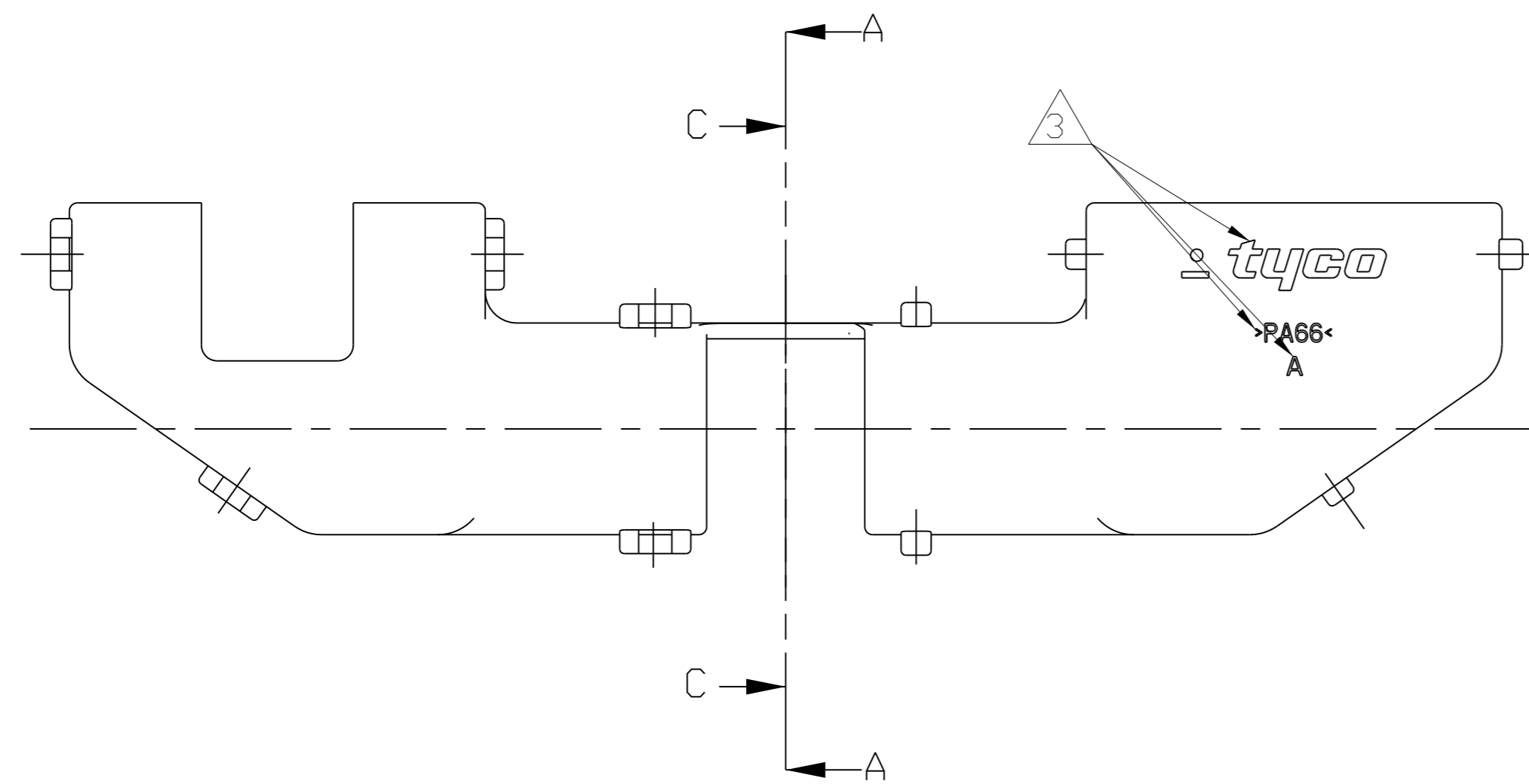

- NOTE
- 1.GENERAL TOLERANCE: ±0.3, ±3°
 - 2.APPLICABLE PLUG HSG P/N: SEE TABLE
 - 3.TYCO TRADE MARK, RECYCLE & CAVITY MARK.

BLACK	PA66	1-1897095-2	0-1897702-2	(B)
BLACK	PA66	0-1897095-2	1-929085-2	
COLOR	MATERIAL	P/N	APPLICABLE PLUG	

0-1897095-2	(B) 1-1897095-2
SCALE 1:1	SCALE 1:1

THIS DRAWING IS A CONTROLLED DOCUMENT FOR TYCO ELECTRONICS CORPORATION. IT IS SUBJECT TO CHANGE AND THE CONTROLLING ENGINEERING ORGANIZATION SHOULD BE CONTACTED FOR THE LATEST REVISION.		DWN: DG JFONG	tyco Tyco Electronics AMP Kyungsan Korea	
DIMENSIONS: mm	TOLERANCES UNLESS OTHERWISE SPECIFIED:	CHK: YM CHOI	NAME: COVER HSG FOR 2.8mm FLAT SENSOR 2P PLUG ASS'Y	
3rd ANGLE PROJECTION	0 PLC ± 1 PLC ± 2 PLC ± SEE NOTE 3 PLC ± 4 PLC ±	APVD: HG CHOI	SIZE: A2	CAGE CODE: C=1897095
MATERIAL: SEE NOTE	ANGLES: ± FINISH: ±	PRODUCT SPEC: APPLICATION SPEC	WEIGHT: A2	DRAWING NO: C=1897095
		WEIGHT: CUSTOMER DRAWING	SCALE: 2:1	SHEET 1 OF 1 REV B