

4

3

2

1

THIS DRAWING IS UNPUBLISHED.

RELEASED FOR PUBLICATION

2006

© COPYRIGHT 2006 BY TE CONNECTIVITY

ALL RIGHTS RESERVED.

REVISIONS

| P | LTR | DESCRIPTION             | DATE      | DWN | APVD |
|---|-----|-------------------------|-----------|-----|------|
|   | A   | RELEASED                | 12/JUN'06 | IS  | JK   |
|   | B   | REVISED (ECR-06-019848) | 28/AUG'06 | IS  | JK   |
|   |     |                         |           |     |      |
|   |     |                         |           |     |      |

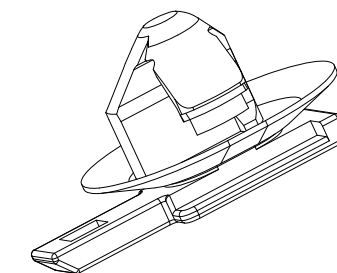
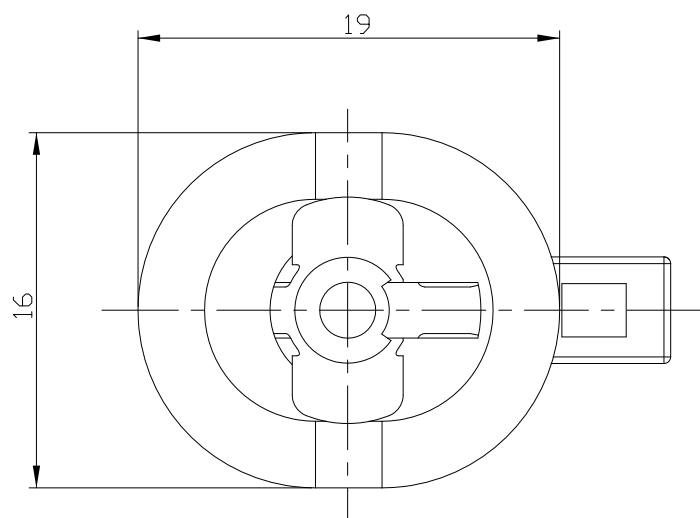

SCALE 2:1

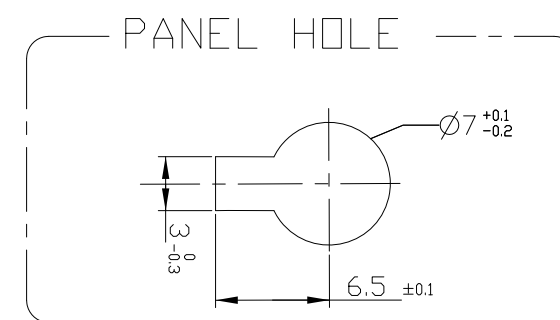
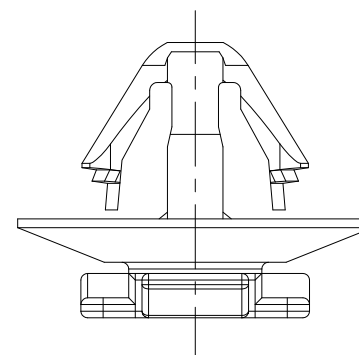
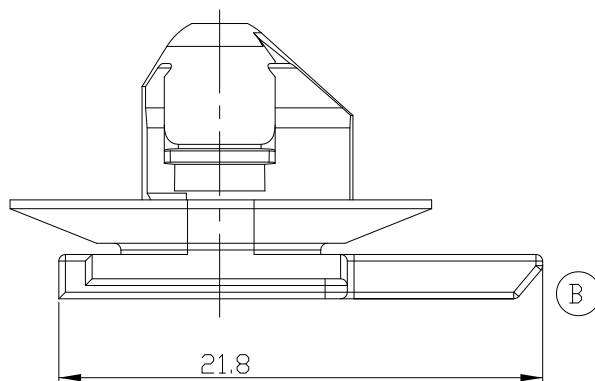
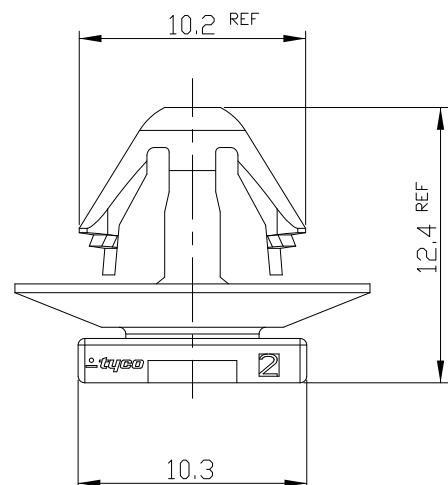

PANEL THICKNESS: 2.4mm

- 1. GENERAL TOLERANCE:  $\pm 0.4$ ,  $\pm 4^\circ$
- 2. NO WEATHERABILITY TEST IS REQUIRED.

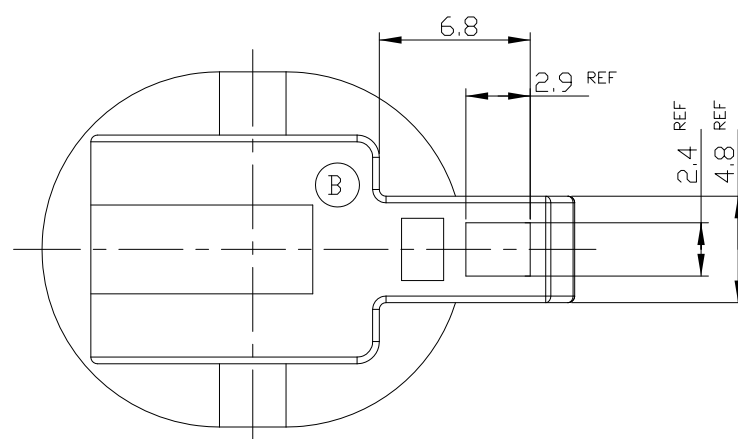

|             |                               |          |       |
|-------------|-------------------------------|----------|-------|
| 0-1897000-2 | CLIP HSG FOR GLOW PLUG 1P CAP | PA66     | BLACK |
| P/N         | DESCRIPTION                   | MATERIAL | COLOR |

|  |  |                  |                                       |  |
|--|--|------------------|---------------------------------------|--|
| THIS DRAWING IS A CONTROLLED DOCUMENT. |  | DWN<br>IS SHIN   |                                       |  |
| DIMENSIONS:<br>mm                      |  | CHK<br>YM CHOI   |                                       |  |
| TOLERANCES UNLESS OTHERWISE SPECIFIED: |  | APVD<br>JK SONG  | NAME<br>CLIP HSG FOR GLOW PLUG 1P CAP |  |
| 0 PLC $\pm$                            |  | PRODUCT SPEC     | SIZE                                  |  |
| 1 PLC $\pm$                            |  | -                | CAGE CODE                             |  |
| 2 PLC $\pm$                            |  | APPLICATION SPEC | DRAWING NO                            |  |
| 3 PLC $\pm$                            |  | -                | RESTRICTED TO                         |  |
| 4 PLC $\pm$                            |  | WEIGHT           | A300779 C-1897000                     |  |
| ANGLES $\pm$                           |  | -                | SCALE 3:1                             |  |
| FINISH                                 |  | -                | SHEET 1 OF 1                          |  |
| MATERIAL                               |  | -                | REV B                                 |  |
| -                                      |  | -                | CUSTOMER DRAWING                      |  |