

REVISIONS					
P.	LTN	DESCRIPTION	DATE	DWN	APVD
B1	REV PER	ECO-14-016878	24NOV2014	RG	MC

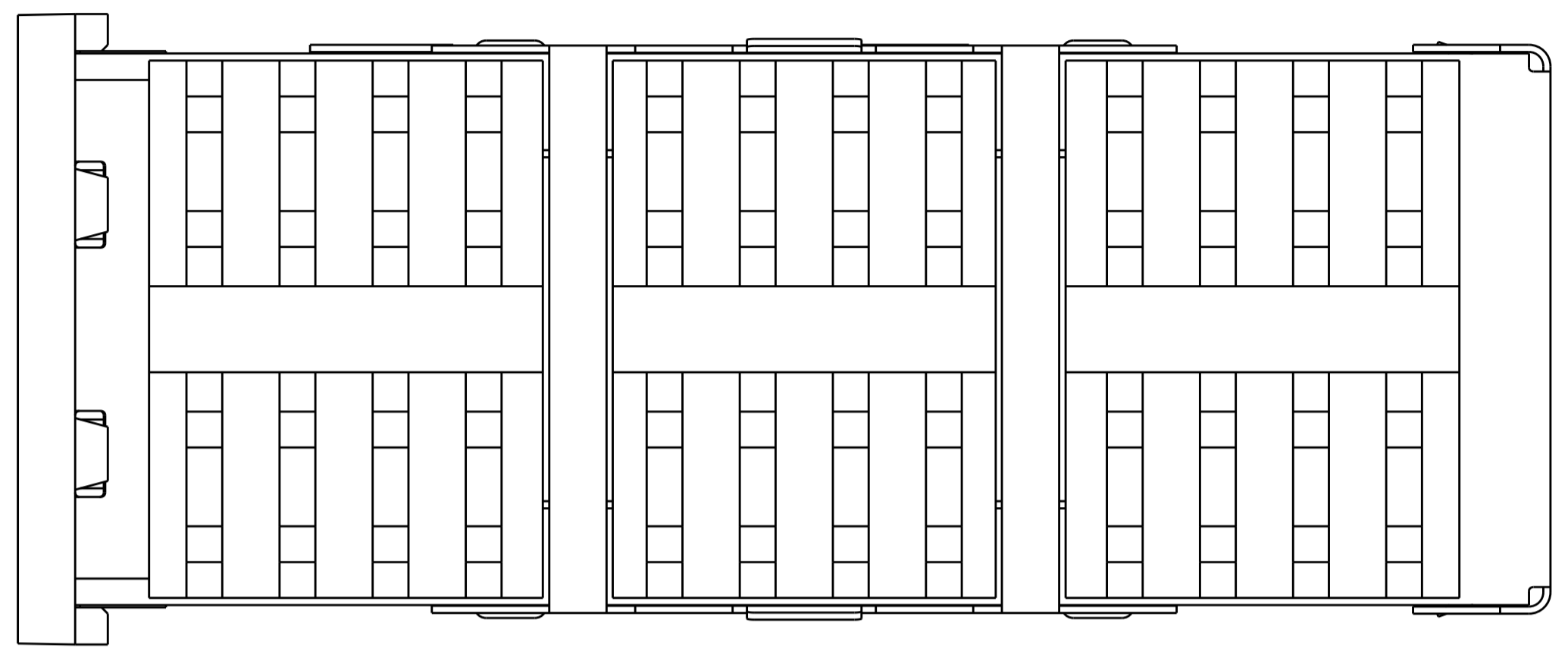

- 1 CAGE MATERIAL: NICKEL SILVER, 0.25 THICK
 HEAT SINK MATERIAL: ALUMINUM
 HEAT SINK CLIP MATERIAL: STAINLESS STEEL
 EMI SPRING MATERIAL: COPPER ALLOY
 FRONT FLANGE MATERIAL: ZINC ALLOY
- 2 MINIMUM PITCH DIMENSION.
- 3. MATES WITH QSFP MSA COMPATIBLE TRANSCEIVER.
- 4 REFERENCE APPLICATION SPEC 114-13218 FOR RECOMMENDED DRILL HOLE DIAMETER AND PLATING THICKNESS.
- 5 DATUMS AND BASIC DIMENSIONS ESTABLISHED BY CUSTOMER.
- 6 DIMENSION C IS THE NOMINAL THICKNESS OF CUSTOMER SUPPLIED PC BOARD,
 SINGLE SIDED PC BOARD MINIMUM THICKNESS: 1.45
 DOUBLE SIDED PC BOARD MINIMUM THICKNESS: 2.7.
- 7 HEAT SINK AND CLIP SHIPPED ASSEMBLED TO CAGE ASSEMBLY
 CAGE ASSEMBLY MAY BE PRESSED INTO THE PCB AS SHIPPED.
- 8 DATUM -A- IS TOP SURFACE OF HOST BOARD.
- 9 SURFACE TRACES PERMITTED WITHIN THIS AREA EXCEPT WHERE CAGE STANDOFFS, SHOWN IN DETAIL J, CONTACT PC BOARD.
- 10 DIMENSION APPLIES WITH MODULE INSTALLED IN THE CAGE.
- 11 2D BARCODE AND DATE CODE (YYWW) MARKED ON BACK OF CAGE.
- 12 EMI SPRING FINISH: 2µm MIN TIN.
 FRONT FLANGE FINISH: 3µm MIN TIN OVER 1.27µm MIN NICKEL
 OVER 5.08µm MIN COPPER.
 HEAT SINK FINISH: 0.076µm MIN NICKEL.

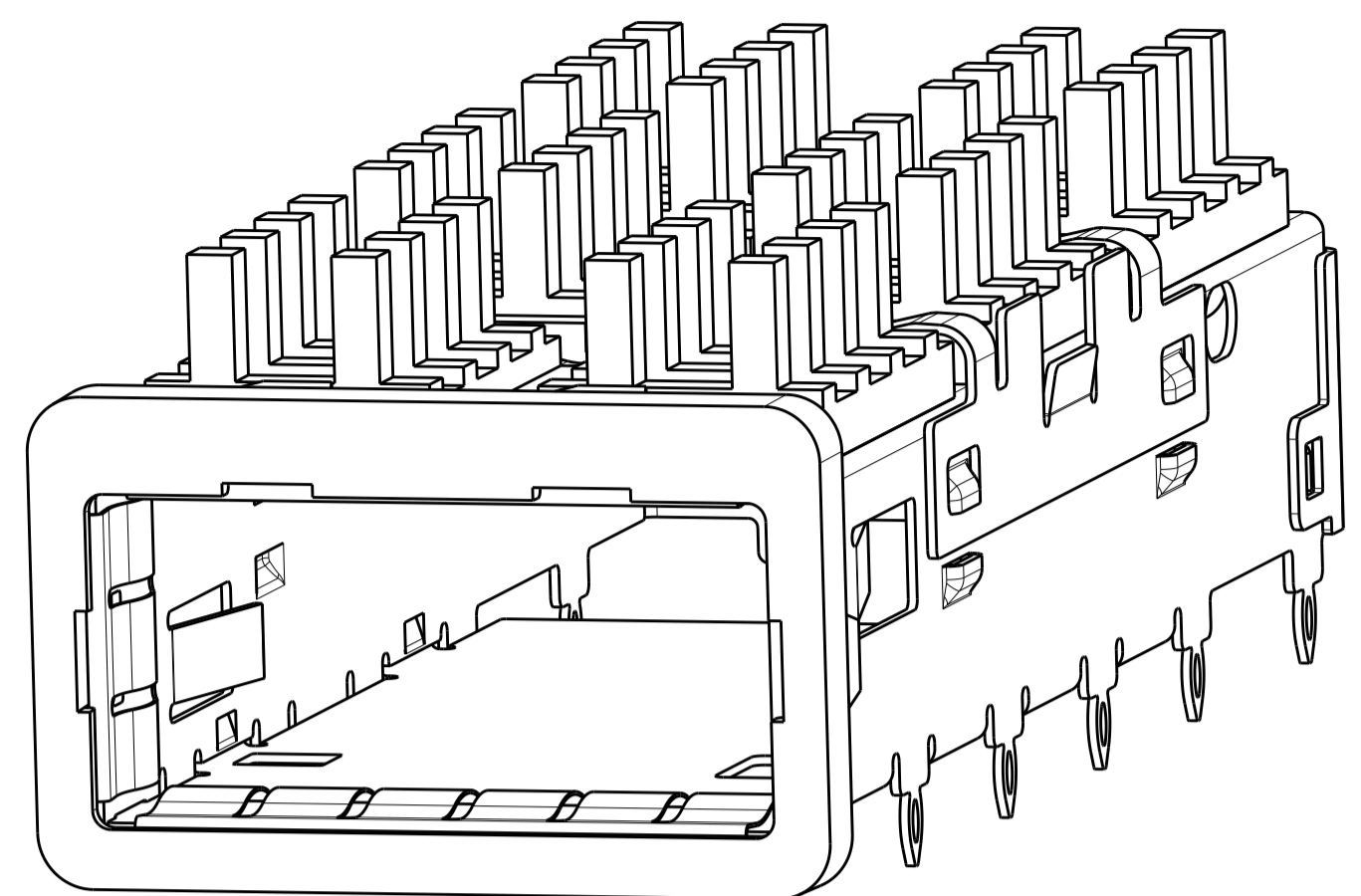
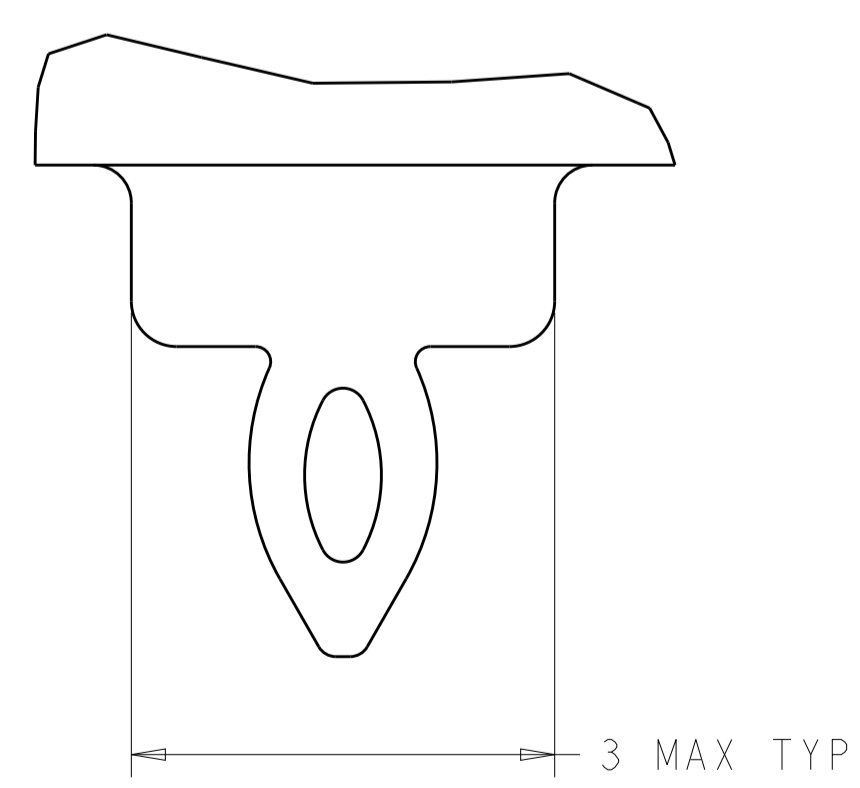
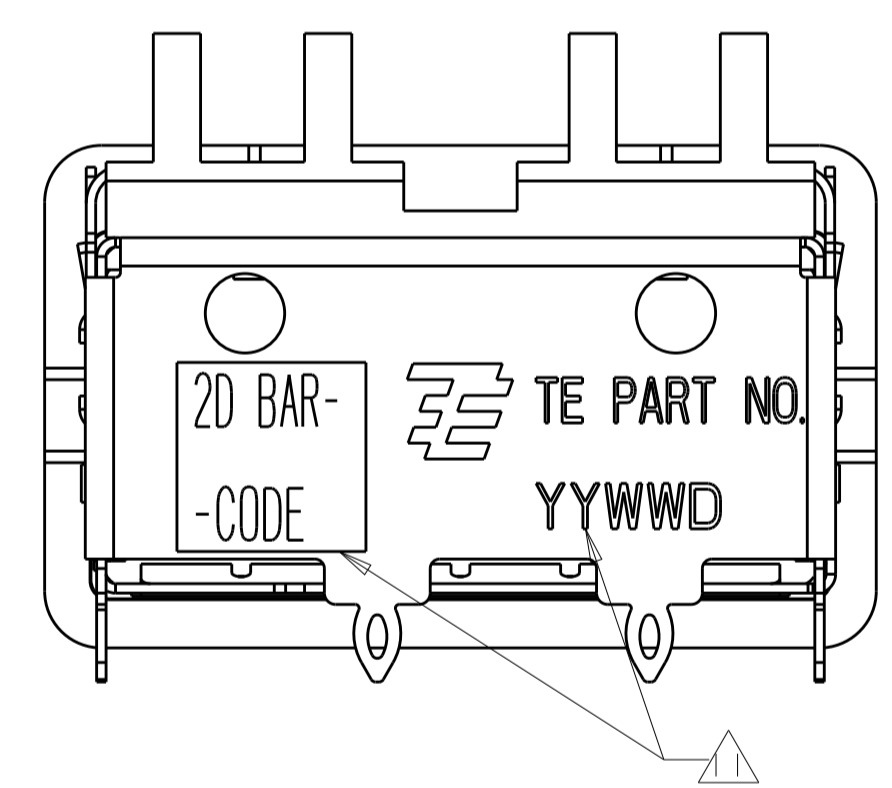
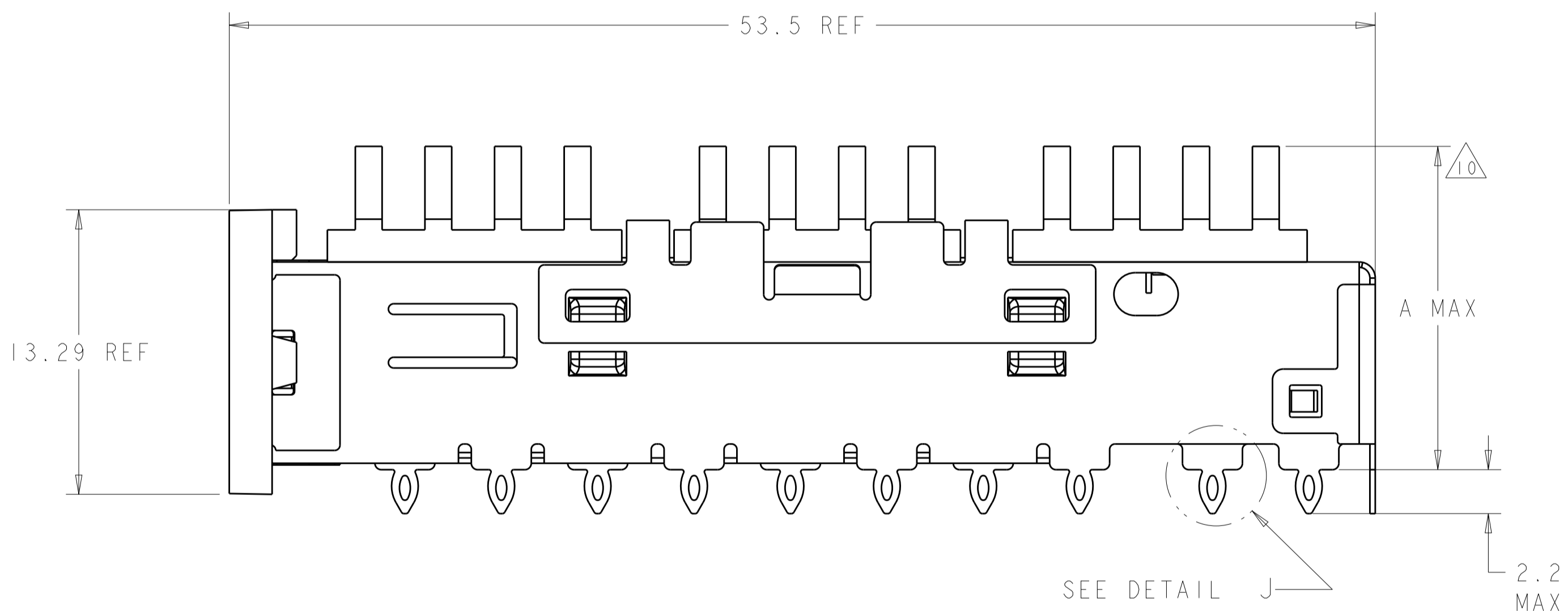
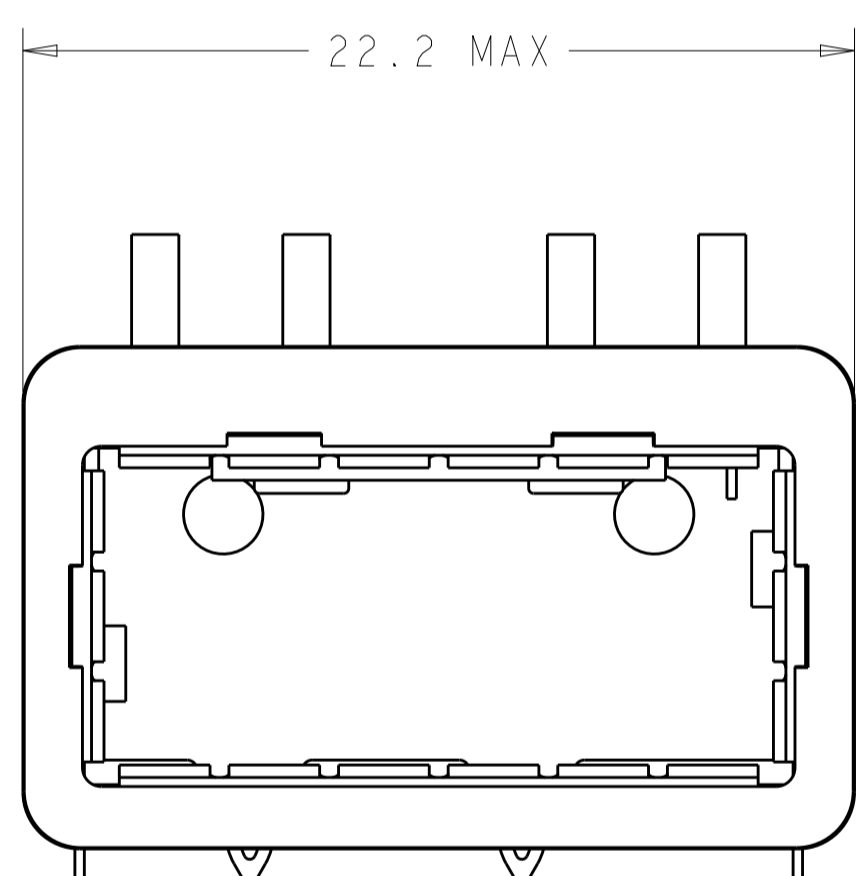

DETAIL J
 SCALE 20:1

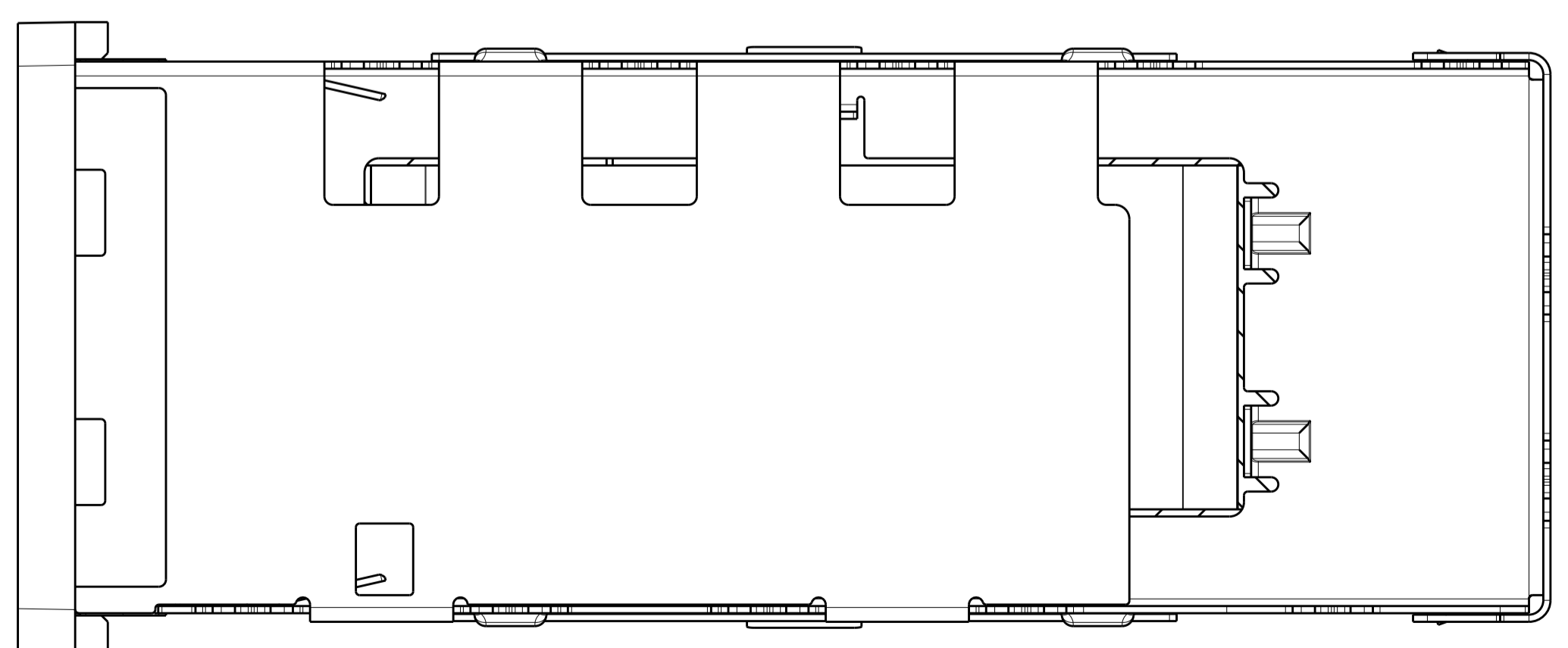

23.0	NETWORKING HEAT SINK	1888968-3
16.0	SAN HEAT SINK (SHOWN)	1888968-2
13.7	PCI HEAT SINK	1888968-1
A	DESCRIPTION	PART NUMBER

THIS DRAWING IS A CONTROLLED DOCUMENT.		DWN C. VALENTINE 19FEB2007	TE Connectivity NAME CAGE ASSEMBLY, BEHIND BEZEL, QSFP WITH HEAT SINK
DIMENSIONS:		CHK E. BRIGHT 19FEB2007	
mm	TOLERANCES UNLESS OTHERWISE SPECIFIED:	APVD E. BRIGHT 19FEB2007	PRODUCT SPEC
0 PLC	±	PRODUCT SPEC	108-2286
1 PLC	±0.5	APPLICATION SPEC	114-13218
2 PLC	±0.13	WEIGHT	-
3 PLC	±0.013	CUSTOMER DRAWING	SCALE 5:1 SHEET 1 OF 5 REV B1
4 PLC	±0.001		
ANGLES	±0.0001		
MATERIAL	FINISH		

REVISIONS				
P.	LTN	DESCRIPTION	DATE	OWN APVD
-	-	SEE SHEET 1	-	-

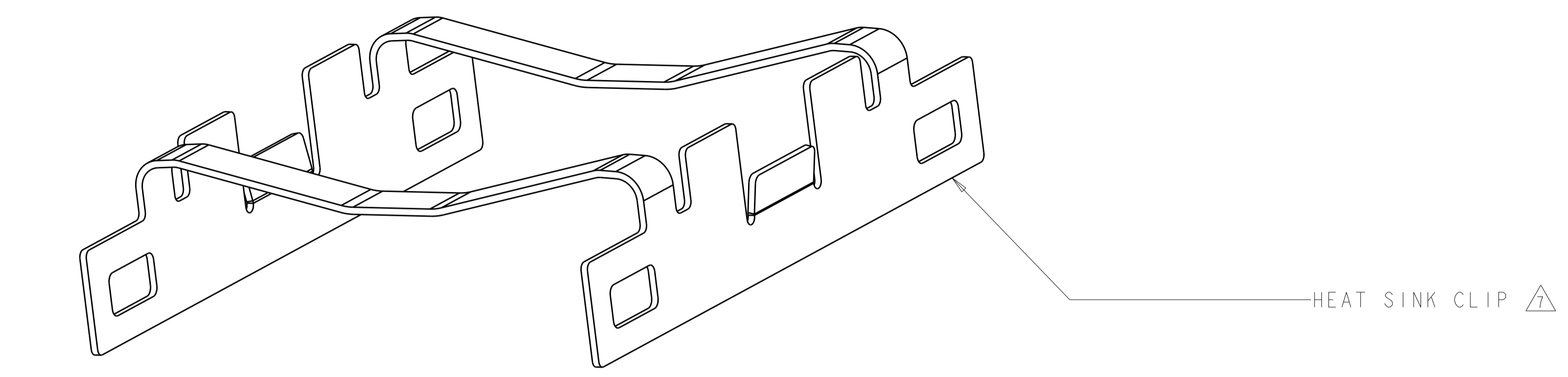

HEAT SINK CLIP

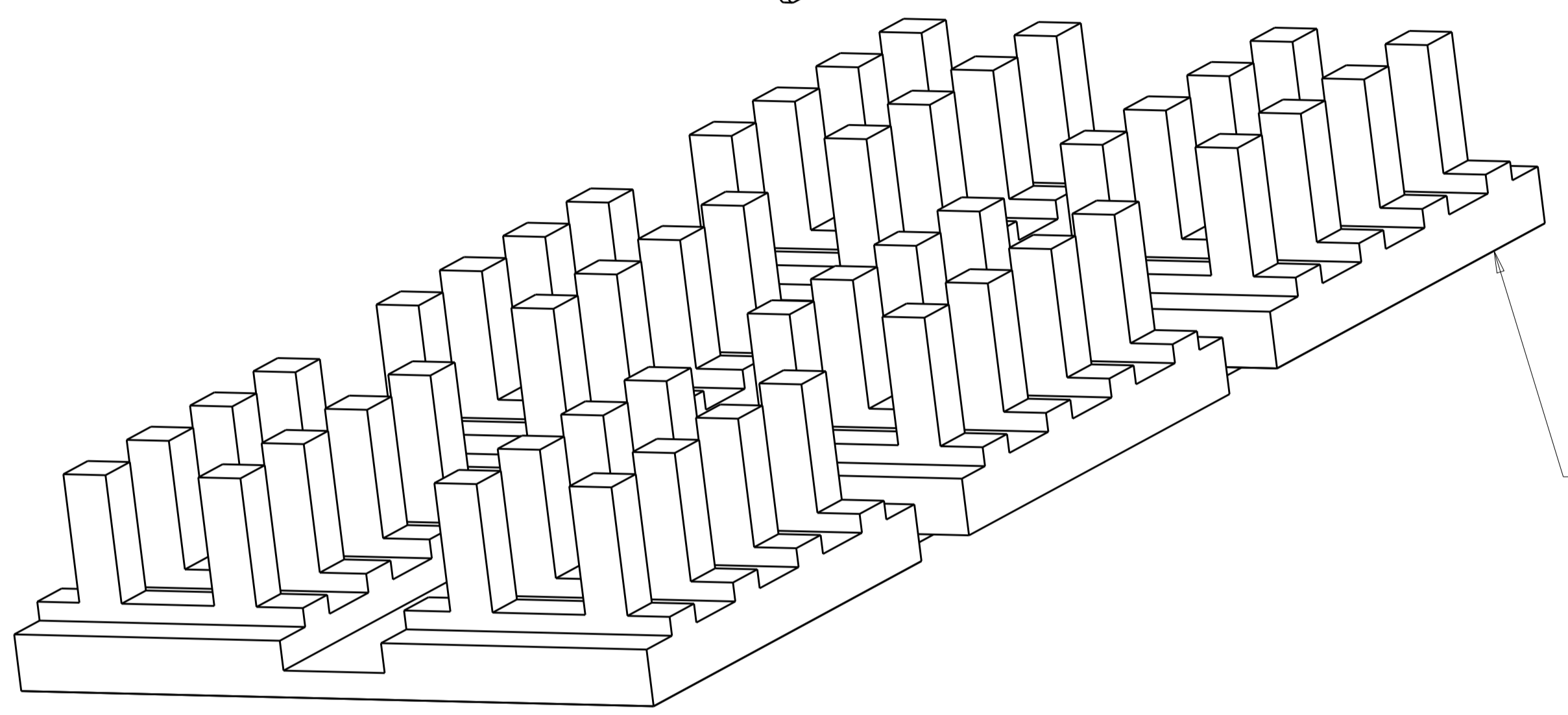

HEAT SINK

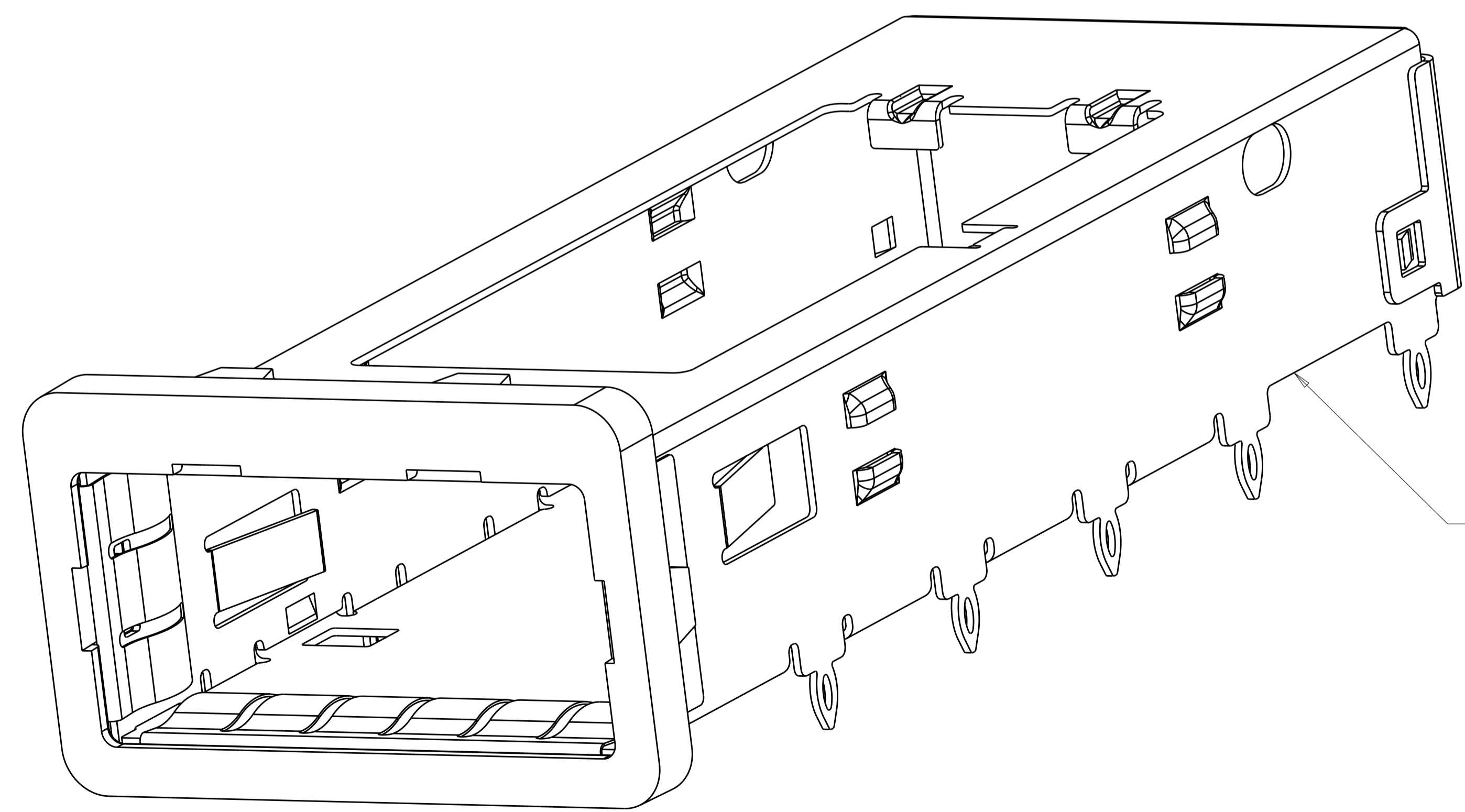

SINGLE QSFP CAGE ASSEMBLY

EXPLODED VIEW
SCALE 8:1

THIS DRAWING IS A CONTROLLED DOCUMENT.		OWN C. VALENTINE 19FEB2007	TE Connectivity NAME CAGE ASSEMBLY, BEHIND BEZEL, QSFP, WITH HEAT SINK PRODUCT SPEC 108-2286 APPLICATION SPEC 114-13218 WEIGHT - CUSTOMER DRAWING	RESTRICTED TO	
DIMENSIONS:		CHK E. BRIGHT 19FEB2007		SIZE	A1
TOLERANCES UNLESS OTHERWISE SPECIFIED:		APVD E. BRIGHT 19FEB2007		CAGE CODE	100779
mm 0 PLC ± 1 PLC ±0.5 2 PLC ±0.13 3 PLC ±0.013 4 PLC ±0.001 ANGLES ±		DRAWING NO 1888968 SCALE 5:1 SHEET 2 OF 5 REV B1			
MATERIAL		FINISH			

REVISIONS				
P.	LTM	DESCRIPTION	DATE	APVD
-	-	SEE SHEET 1	-	-

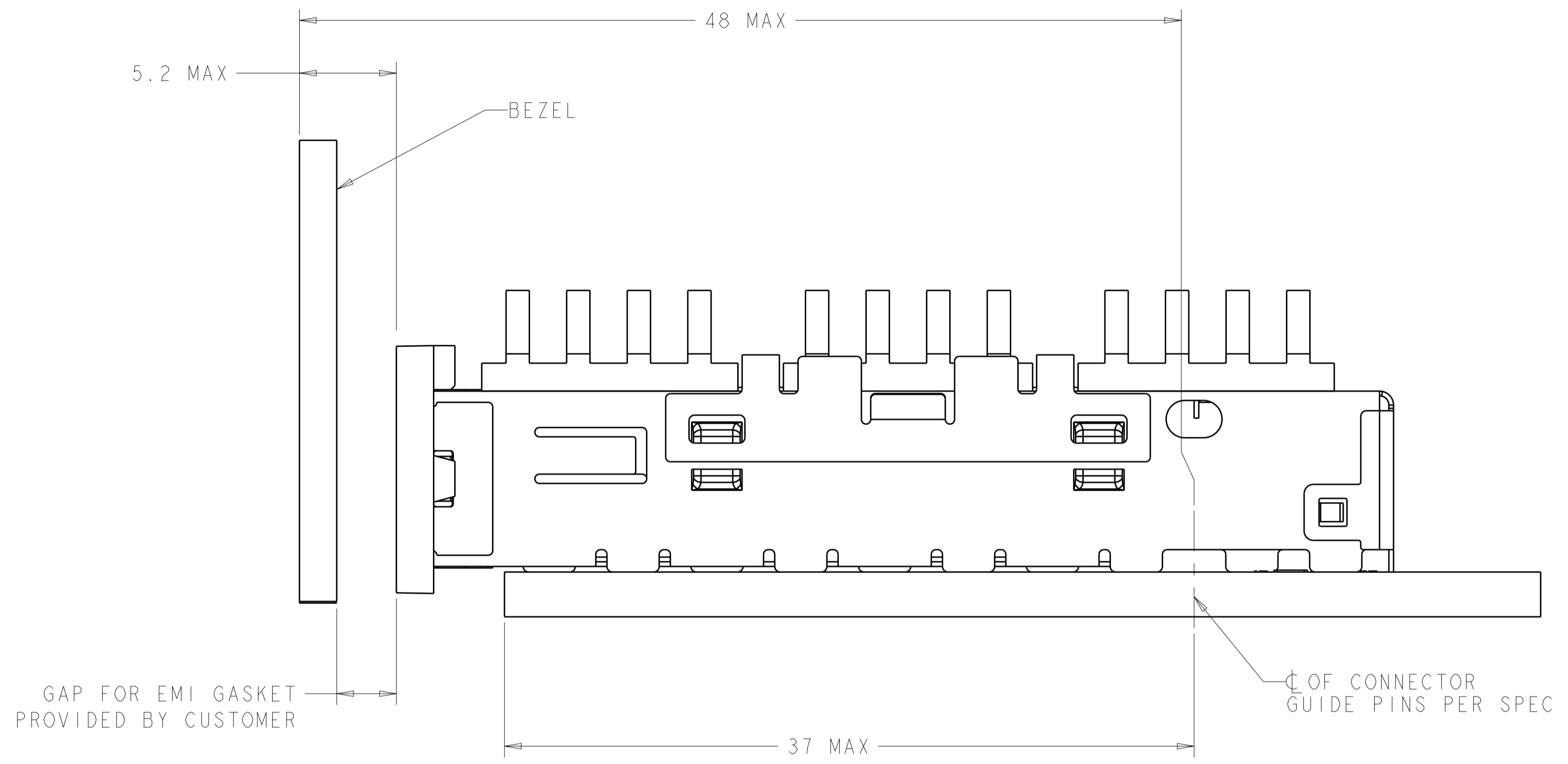
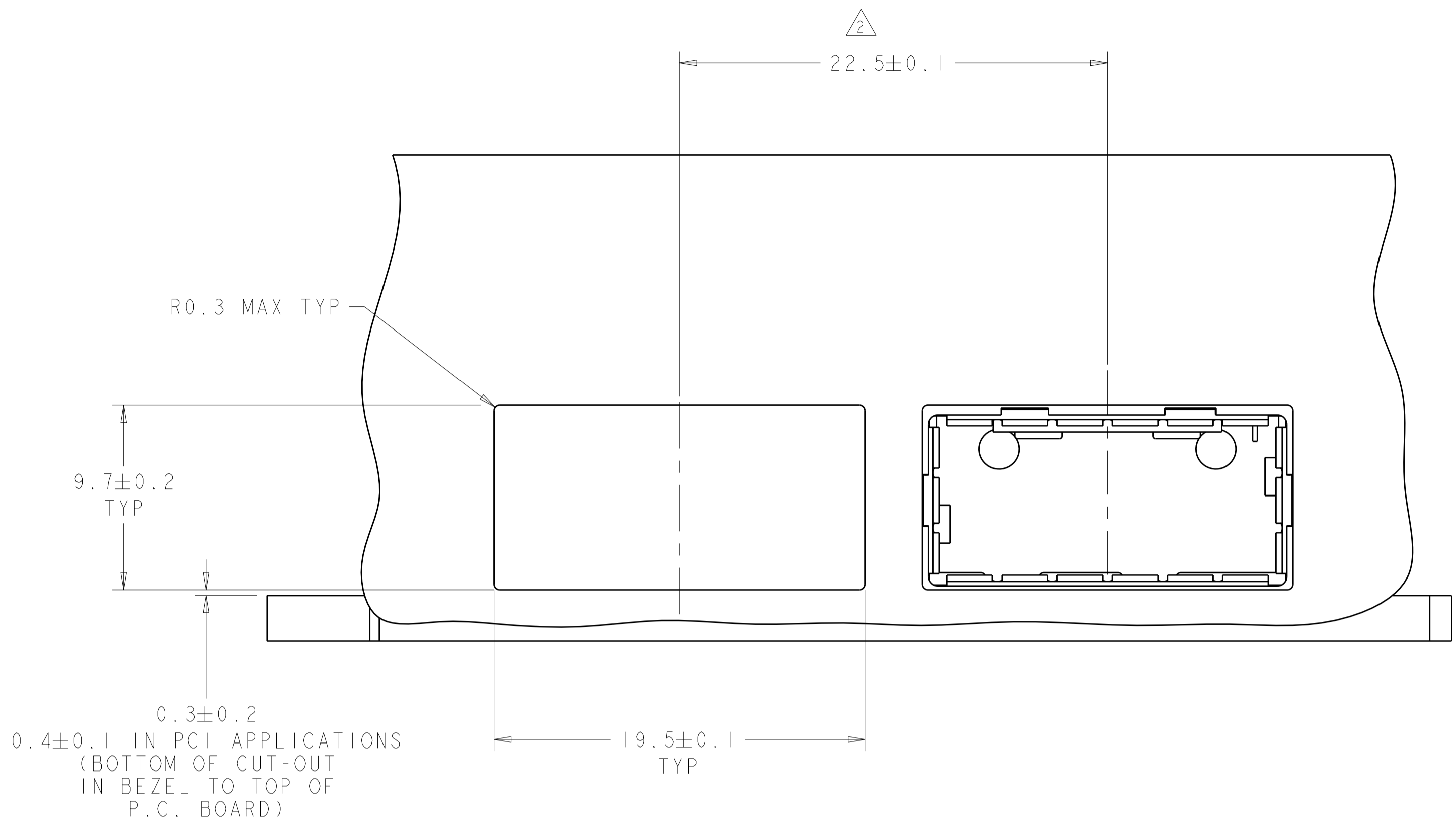

ONE SIDED CONFIGURATION

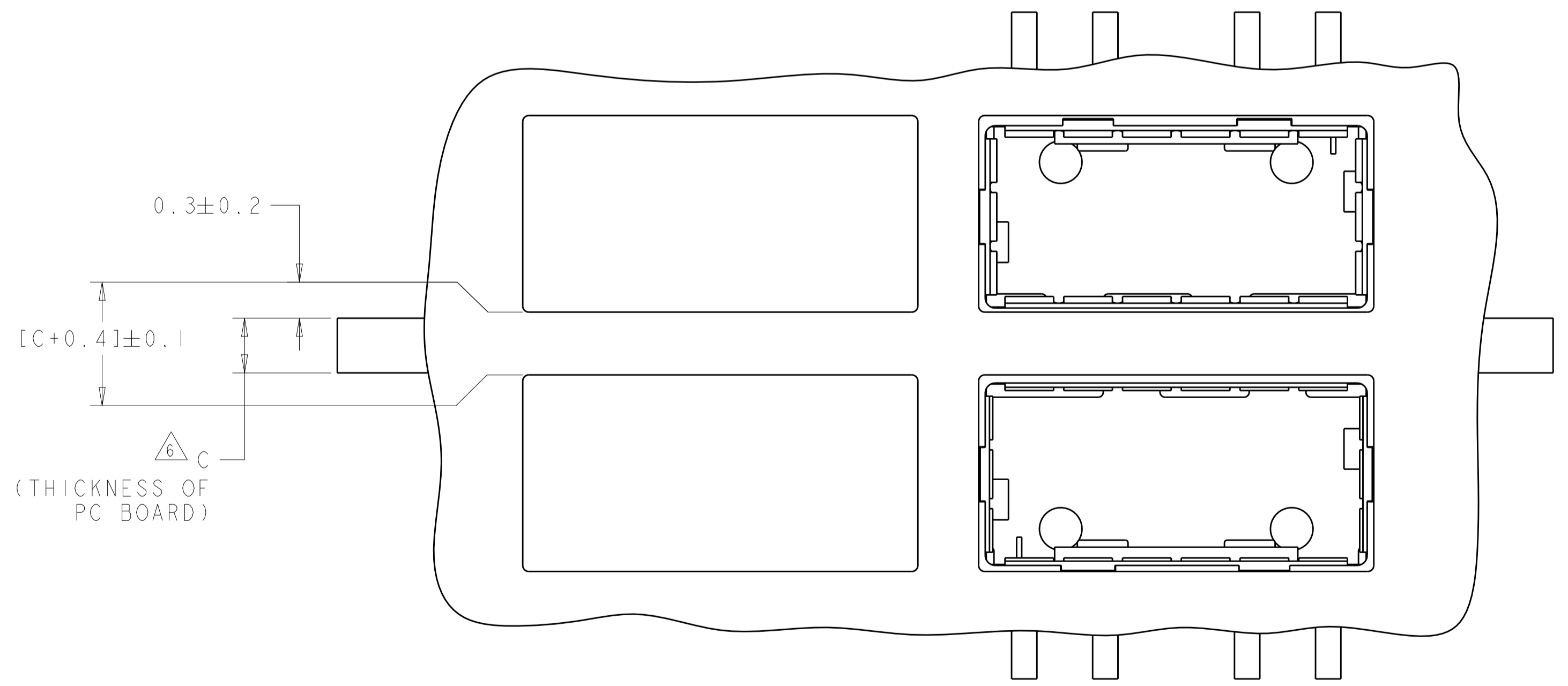

BELLY TO BELLY CONFIGURATION
 SIMILAR TO ONE SIDED EXCEPT
 WHERE NOTED

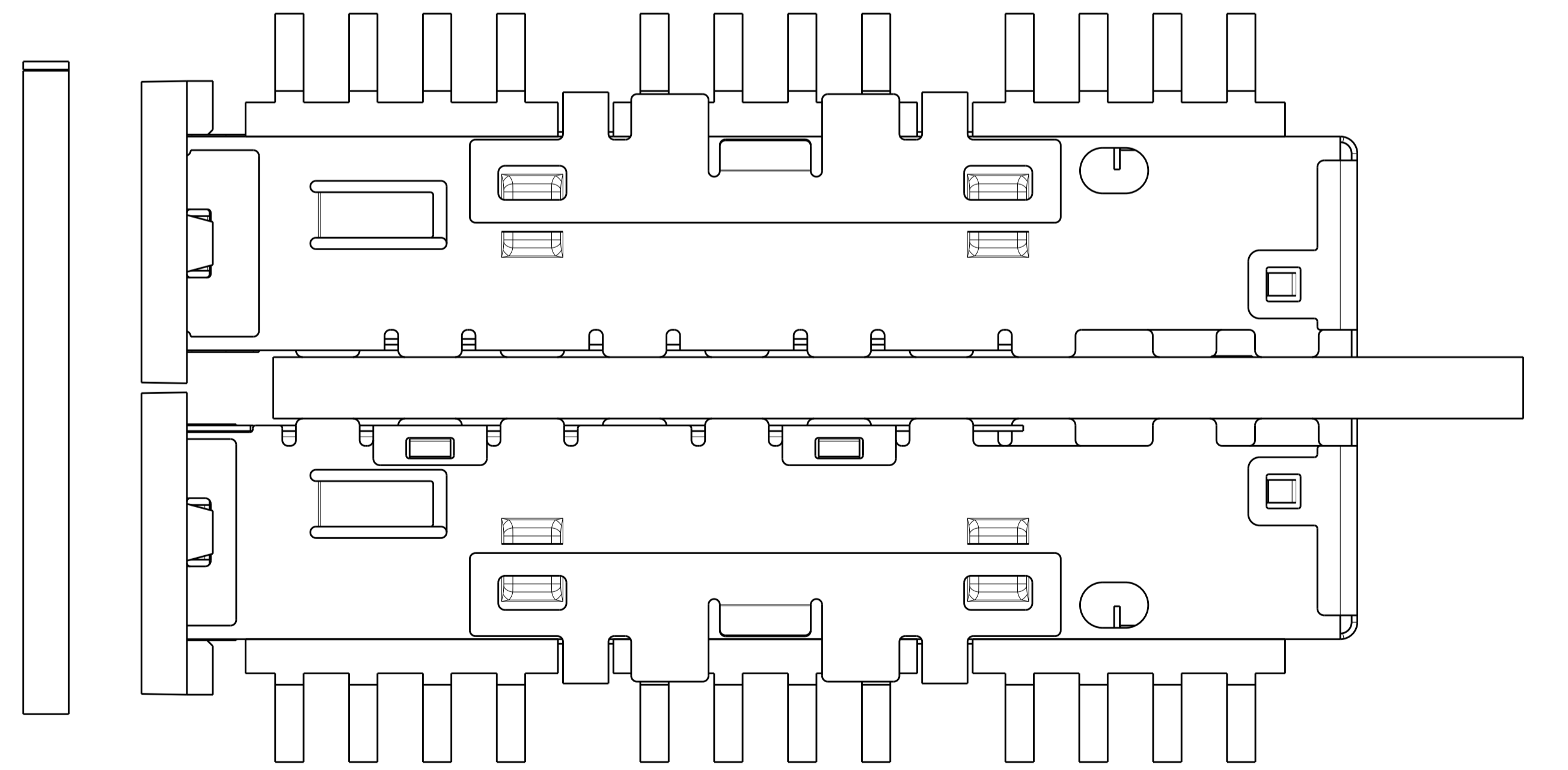

THIS DRAWING IS A CONTROLLED DOCUMENT.		DWN C. VALENTINE 19FEB2007 CHK E. BRIGHT 19FEB2007 APVD E. BRIGHT 19FEB2007	STE TE Connectivity NAME CAGE ASSEMBLY, BEHIND BEZEL, QSFP, WITH HEAT SINK PRODUCT SPEC 108-2286 APPLICATION SPEC 114-13218 WEIGHT - CUSTOMER DRAWING
DIMENSIONS: mm 	TOLERANCES UNLESS OTHERWISE SPECIFIED: 0 PLC ±0.5 2 PLC ±0.13 3 PLC ±0.013 4 PLC ±0.0001 ANGLES ±0.0001	SIZE CAGE CODE DRAWING NO A100779C=1888968	RESTRICTED TO SCALE 5:1 SHEET 3 OF 5 REV B1

REVISIONS				
P.	LTN	DESCRIPTION	DATE	APP'D
-	-	SEE SHEET 1	-	-

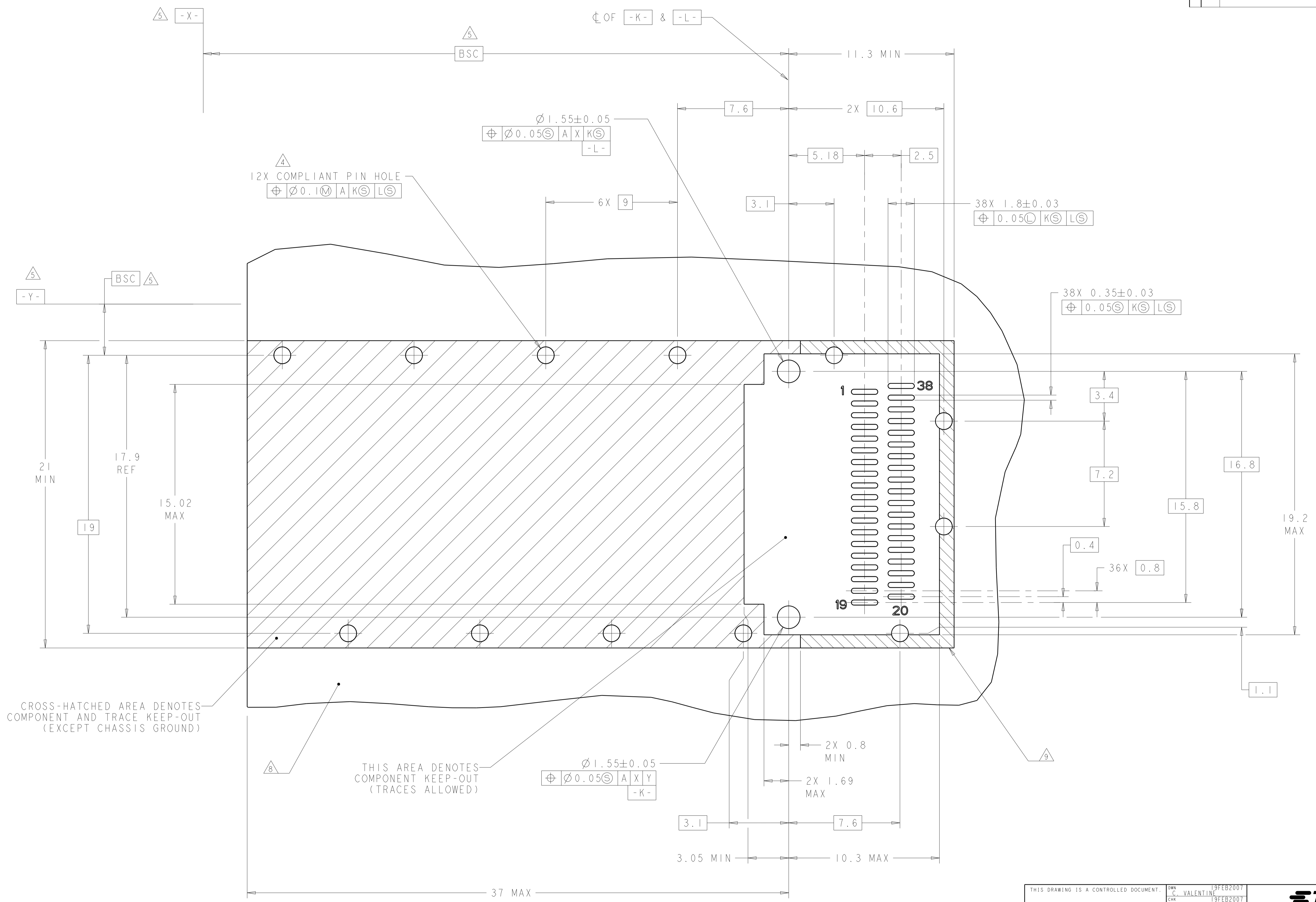

CROSS-HATCHED AREA DENOTES COMPONENT AND TRACE KEEP-OUT (EXCEPT CHASSIS GROUND)

THIS AREA DENOTES COMPONENT KEEP-OUT (TRACES ALLOWED)

RECOMMENDED PCB LAYOUT
 SINGLE SIDED CONFIGURATION
 SCALE 8:1

THIS DRAWING IS A CONTROLLED DOCUMENT.		DWN C. VALENTINE 19FEB2007 CHK E. BRIGHT 19FEB2007 APVD E. BRIGHT 19FEB2007	TE Connectivity
DIMENSIONS: mm	TOLERANCES UNLESS OTHERWISE SPECIFIED: 0 PLC ±.5 1 PLC ±0.13 2 PLC ±0.13 3 PLC ±0.013 4 PLC ±0.001 ANGLES ±.001	NAME CAGE ASSEMBLY, BEHIND BEZEL, QSFP WITH HEAT SINK PRODUCT SPEC 108-2286 APPLICATION SPEC 114-13218 WEIGHT - CUSTOMER DRAWING	
MATERIAL - FINISH -		SIZE CAGE CODE DRAWING NO A100779C=1888968	RESTRICTED TO SCALE 4:1 SHEET 4 OF 5 REV B1

REVISIONS				
P.	LTN.	DESCRIPTION	DATE	APPD.
-	-	SEE SHEET 1	-	-

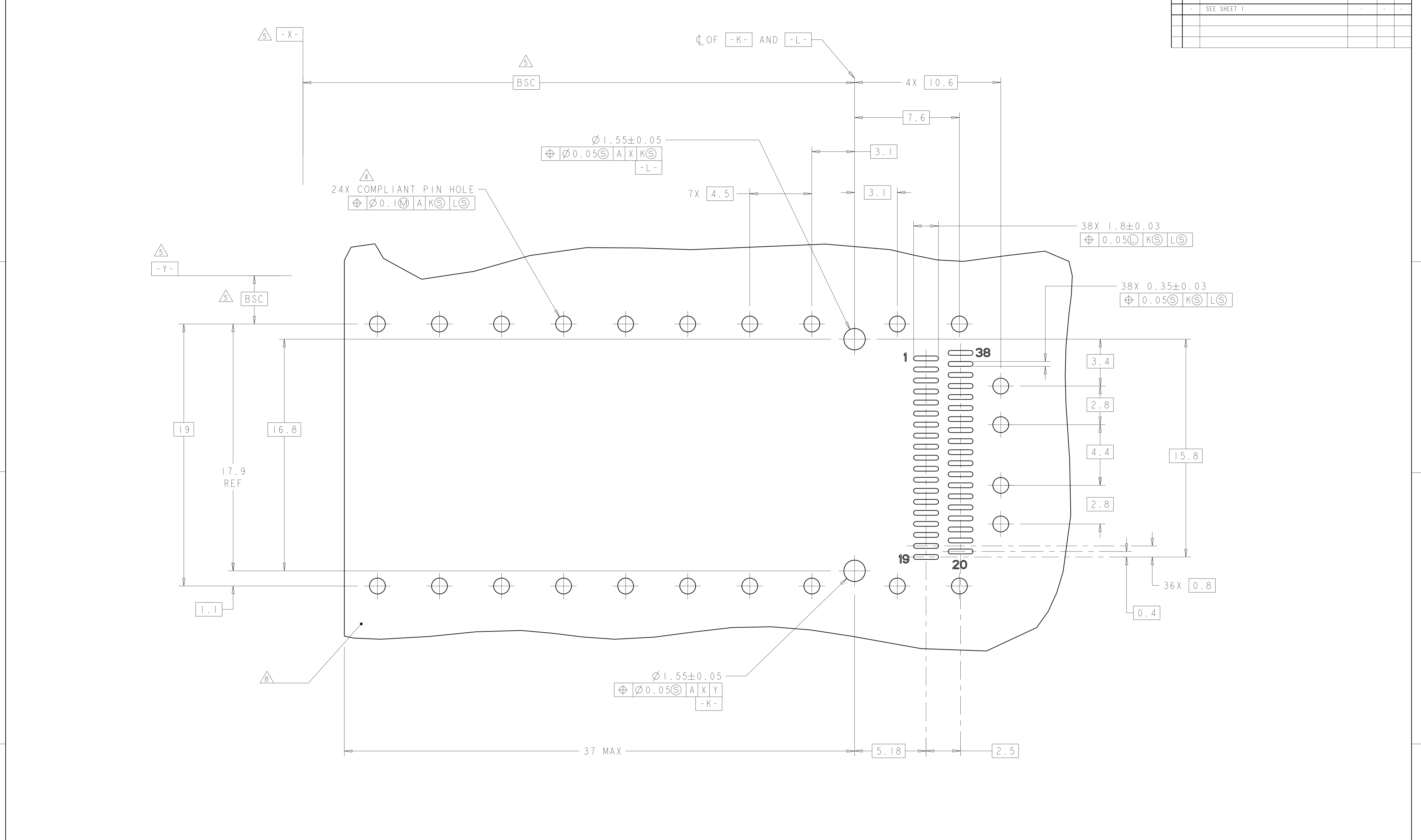

RECOMMENDED PCB LAYOUT
 BELLY TO BELLY CONFIGURATION
 SEE SHEET 4 FOR KEEP OUT AREAS
 SCALE 8:1

THIS DRAWING IS A CONTROLLED DOCUMENT.		DWN C. VALENTINE 19FEB2007 CHK E. BRIGHT 19FEB2007 APVD E. BRIGHT 19FEB2007	TE Connectivity
DIMENSIONS: mm 	TOLERANCES UNLESS OTHERWISE SPECIFIED: 0 PLC ±0.5 2 PLC ±0.13 3 PLC ±0.013 4 PLC ±0.001 ANGLES ±0.0001	NAME CAGE ASSEMBLY, BEHIND BEZEL, QSFP WITH HEAT SINK PRODUCT SPEC 108-2286 APPLICATION SPEC 114-13218 WEIGHT - CUSTOMER DRAWING	
MATERIAL	FINISH	SIZE CAGE CODE DRAWING NO A100779C=1888968 SCALE 4:1 SHEET 5 OF 5 REV B1	RESTRICTED TO