

THIS DRAWING IS UNPUBLISHED.

RELEASED FOR PUBLICATION

© COPYRIGHT - TE Connectivity Ltd.

ALL RIGHTS RESERVED.

REVISIONS

| P | LTR | DESCRIPTION | DATE | DWN | APVD |
|---|-----|----------------------------|-----------|-----|------|
| P | | CUTTING BURR DETAILS ADDED | 20NOV2018 | RK | PS |

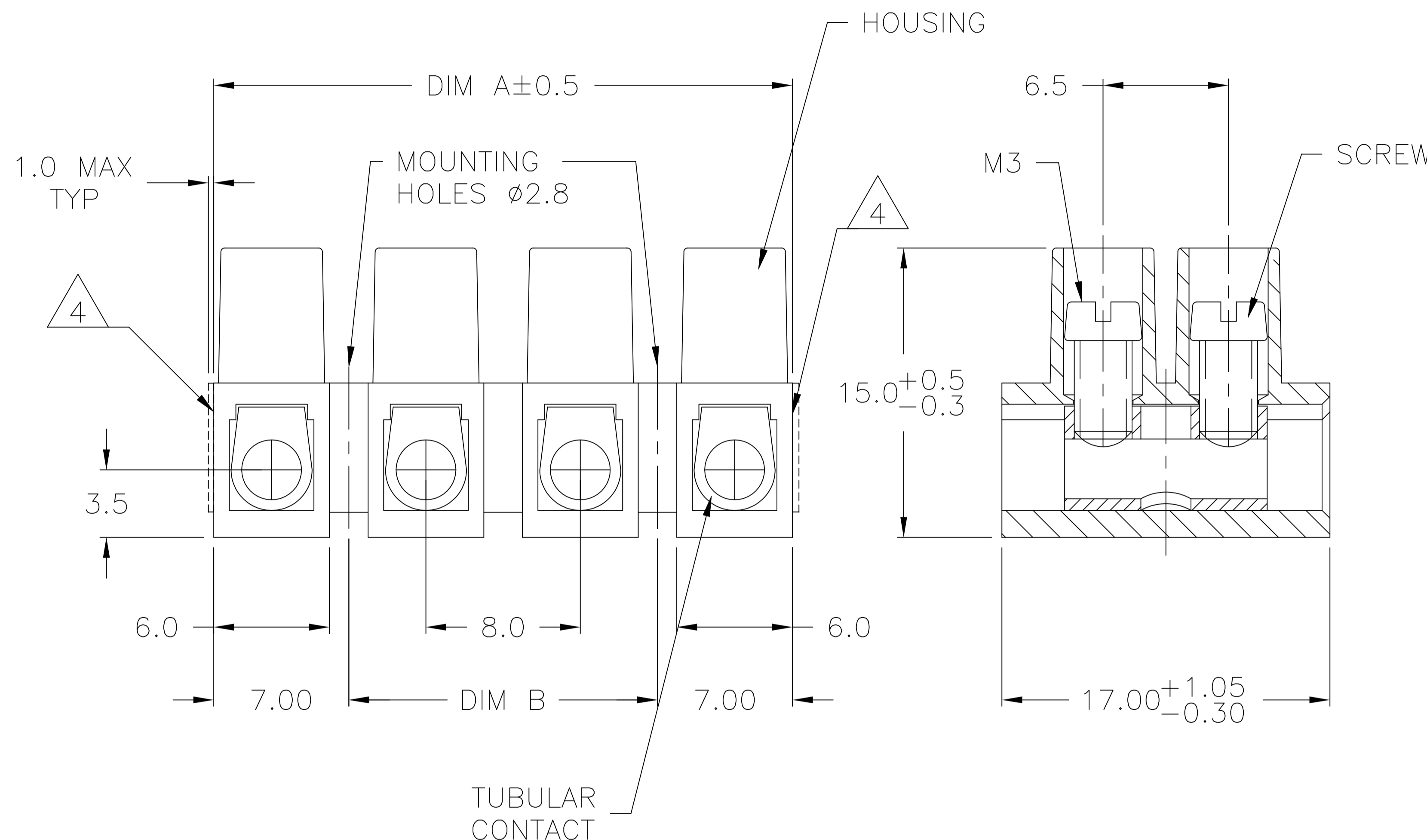

1. MATERIAL:
HOUSING: POLYAMIDE 6, UL94V-0.
COLOR: BROWN.
TUBULAR CONTACT: BRASS TIN PLATED.
SCREW: M3, STEEL, ZINC PLATED W/ NON-HEXAVALENT CHROMATE (CHROME III).
 2. ELECTRICAL:
CURRENT RATING: 30A.
OPERATING VOLTAGE: 250V.
WIRE RANGE: 12-26 AWG.
 3. ENVIRONMENTAL:
CONTINUOUS WORKING TEMP.: -35°C TO +150°C.
- △ 4 CUTTING PROJECTION CAN BE ON BOTH SIDES DEPENDING ON CUTTING LOCATION.
5. CUTTING BURR MAX. 1mm ALLOWED.

| | | | | |
|-------|-------|----------|-------------------|----------------|
| 80.0 | 94.0 | 12 | TSB23012HT | 1-1776323-2 |
| DIM B | DIM A | NO. POSN | T & B PART NUMBER | TE PART NUMBER |

THIS DRAWING IS A CONTROLLED DOCUMENT.

| | |
|-------------------|--|
| DIMENSIONS: mm | TOLERANCES UNLESS OTHERWISE SPECIFIED: |
| | 0 PLC ± - |
| | 1 PLC ± 0.3 |
| | 2 PLC ± 0.25 |
| | 3 PLC ± - |
| | 4 PLC ± - |
| | ANGLES ± 2' |

MATERIAL SEE NOTES FINISH SEE NOTES

| | | |
|------------------|------------|---------|
| DWN | S SCHLEGEL | 3/21/05 |
| CHK | C RICHARD | 3/21/05 |
| APVD | C RICHARD | 3/21/05 |
| PRODUCT SPEC | | |
| APPLICATION SPEC | | |
| WEIGHT | - | |

STE TE Connectivity Ltd.

NAME: HIGH TEMP EUROPA TERMINAL BLOCK
MOUNTING HOLES 2.8 DIA., 8.0mm PITCH

| | | | |
|------|-----------|------------|---------------|
| SIZE | CAGE CODE | DRAWING NO | RESTRICTED TO |
| A3 | 00779 | C=1776323 | - |

CUSTOMER DRAWING SCALE NTS SHEET 1 of 1 REV P